

NOTES:

1. FOR WAVESOLDERING (SOLDER BATH TEMPERATURE 240°C FOR 5 SEC. / AND SOLDER PREHEAT 120°C FOR 120 SEC.)
2. METALSHELLS: COPPER ALLOY; min. 315µm TIN over 40-80µm NICKEL
3. INSULATORS: PBT GF UL 94 V-0; BLACK
4. SIGNAL CONTACTS: COPPER ALLOY
PLATING: 8µm HARD GOLD over min. 50µm NICKEL
5. METAL BRACKETS: ZINC DIE CAST; 300µm COPPER/40-120µm NICKEL/
120-200µm TIN
6. THREADED INSERTS: COPPER ALLOY;
min. 200µm TIN over 80µm NICKEL
7. PCB-SNAPS: COPPER ALLOY; min. 200µm TIN over 80µm NICKEL
PCB-HOLE: $\varnothing 3,1 \pm 0,1$ mm; PCB-THICKNESS: 1,6mm
8. HEXLOCKING SCREWS: STAINLESS STEEL
9. FRAME: PA GF UL 94 V-0; BLACK
10. FIXING PLATE: PBT GF UL 94 V-0; BLACK
11. O-RING: SILICON; BLUE
12. RUBBER GASKET: TPE
13. P.C.B. HOLE DRILLINGS AND RECOMMENDED PANEL CUT-OUT ON SHEET 2
14. RECOMMENDED TORQUE FOR MOUNTING SCREW 35Ncm (3.1 in.LB) /
max.40Ncm (3.5 in.LB)
15. CONNECTOR IS PART MARKED: **4HDD44PAY99R30X CONEC ABC**

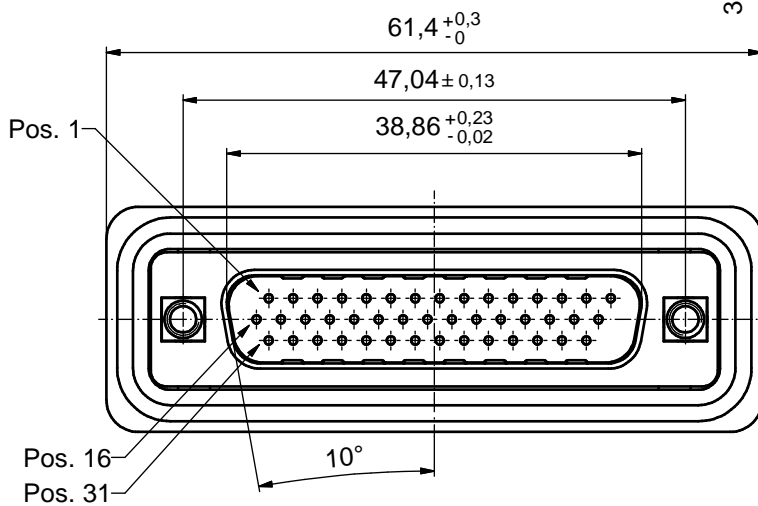

RUBBER GASKET
PLACED ON TOP SURFACE
OF MALE INSULATOR

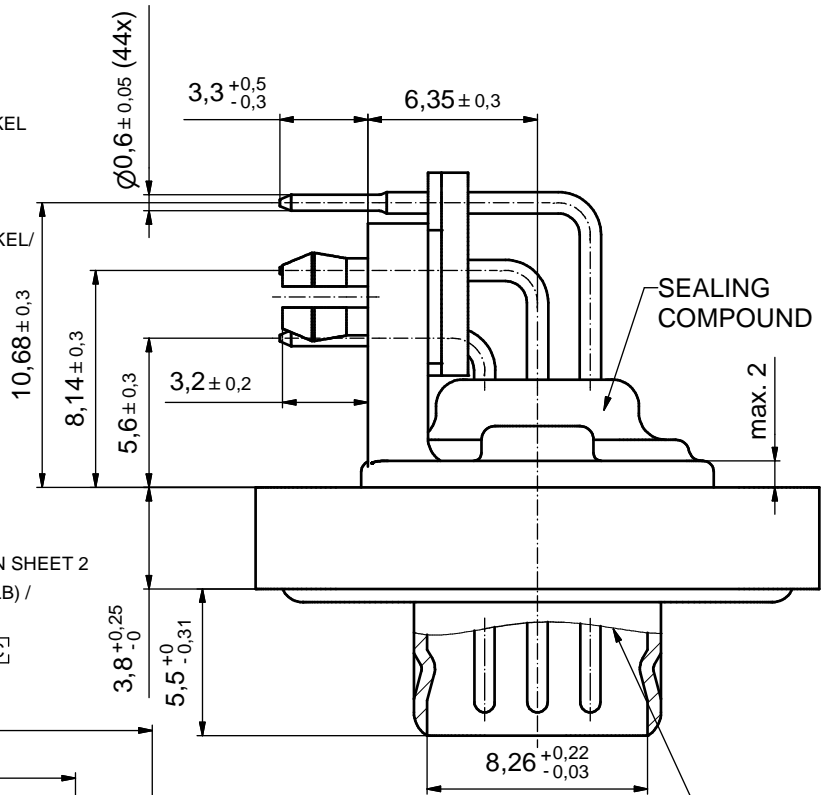
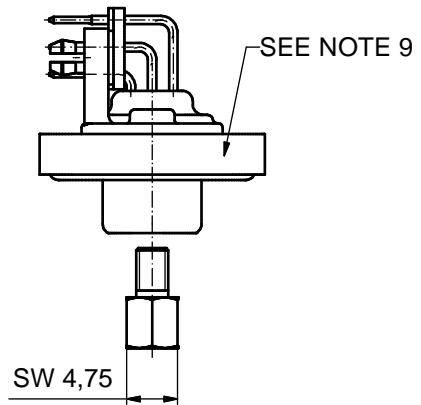
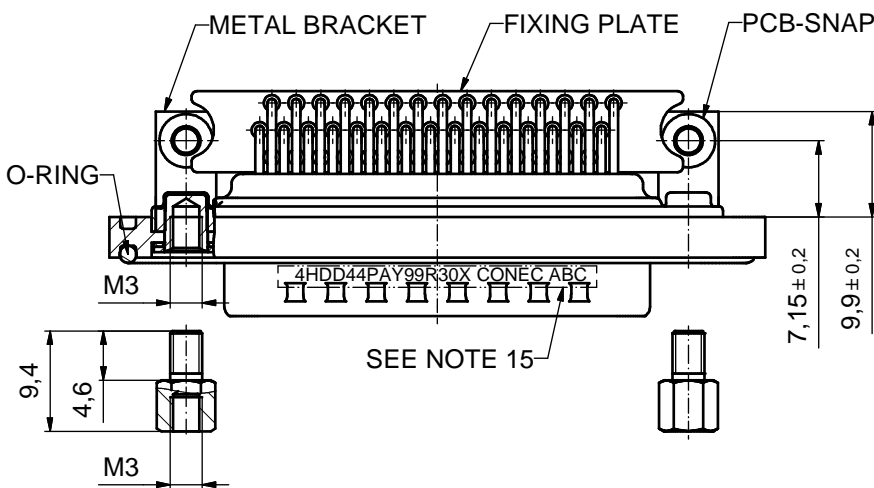
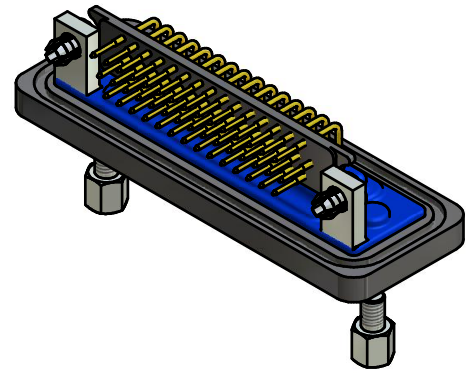

Directive 2002/95/EC
"RoHS"
Compliant

AT ALL TIMES WATER RESISTANT CONNECTORS
NOT IN USE SHOULD BE COVERED
WITH A CONEC WATER RESISTANT CAP
OR WATER TIGHT HOOD.

APPROVAL # FREIGABE # DEBLOCAGE # AUTORIZACION # APPROVAL	
CUSTOMER APPROVAL DATE:	
NAME:	TITLE:
COMPANY NAME:	
APPROVAL # FREIGABE # DEBLOCAGE # AUTORIZACION # APPROVAL	

tolerance				dim. in mm
date				
name				title:
drawn 16.08.2010 Henneboel				
appd. 16.08.2010 Fischer				
norm				threaded insert, metal bracke, snap and fixing-plate
d-old				
DO NOT ALTER CAD DRAWING BY HAND				dwg no: Inventor 10
a Origin				
rev. description date name				DIN-A3
				sh: 1
				part no: 4HDD44PAY99R30X

scale: 2:1 (5:1)	
material: SEE NOTES	
title: D-SUB HD MALE 90° 44pos. SOLDER PIN ANGLED	
threaded insert, metal bracke, snap and fixing-plate	
dwg no: Inventor 10	DIN-A3
sh: 1	
part no: 4HDD44PAY99R30X	

P.C.B. HOLE DRILLINGS

(P.C.B. TOP SIDE)

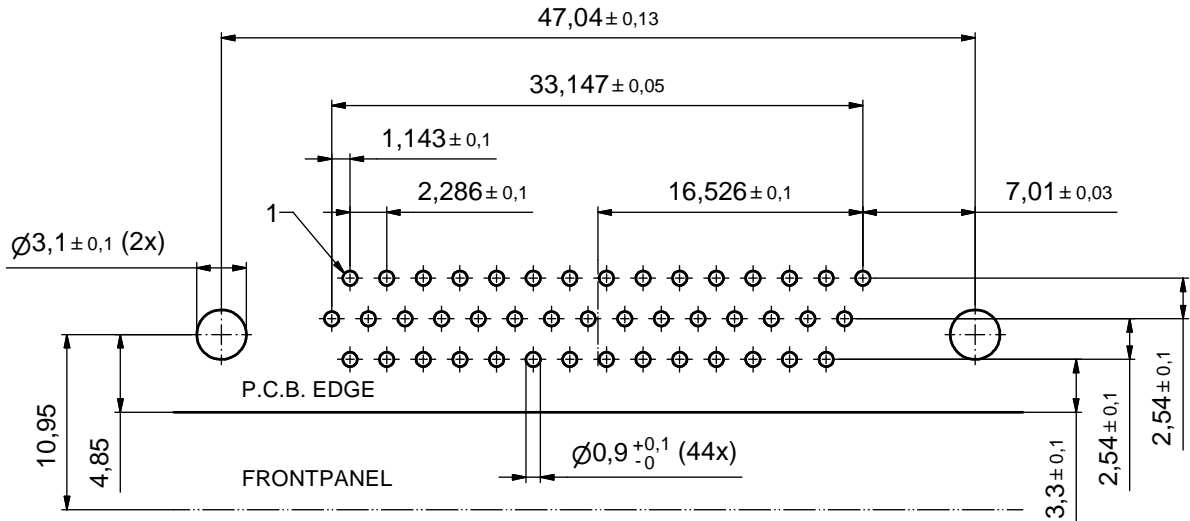

RECOMMENDED PANEL CUT-OUT

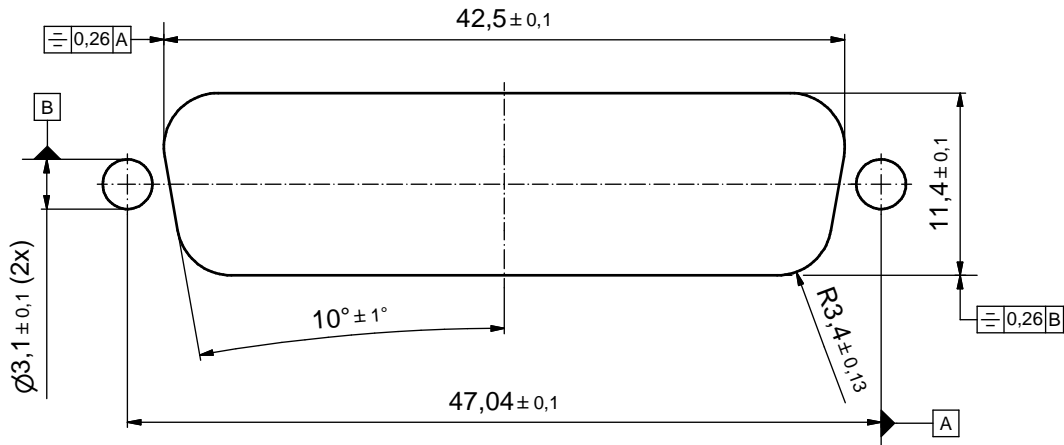

APPROVAL # FREIGABE # DEBLOCAGE # AUTORIZACION # APPROVAL	
CUSTOMER APPROVAL DATE:	
NAME:	TITLE:
COMPANY NAME:	
APPROVAL # FREIGABE # DEBLOCAGE # AUTORIZACION # APPROVAL	

THIS DRAWING MAY NOT BE COPIED OR REPRODUCED IN ANY WAY, AND MAY NOT BE PASSED ON TO A THIRD PARTY WITHOUT WRITTEN PERMISSION. OWNERSHIP AND COPYRIGHT OF CONEC GmbH			
DO NOT ALTER CAD DRAWING BY HAND			
rev.	description	date	name
a	Origin		

tolerance		 dim. in mm
date	name	
drawn	16.08.2010 Henneboel	
appd.	16.08.2010 Fischer	
norm		
d-old		

scale:	3:1	
material:	see sheet 1	
title:	P.C.B. HOLE DRILLINGS PANEL CUT-OUT D-SUB Male 44pos. HD SOLDER PIN 90°	
dwg no:	Inventor 10	DIN-A3
	15K1A710	sh: 2
part no:	SEE SHEET 1	