

## Description:

This N-Channel MOSFET uses advanced SGT technology and design to provide excellent  $R_{DS(on)}$  with low gate charge. It can be used in a wide variety of applications.

## Features:

- 1)  $V_{DS}=30V, I_D=210A, R_{DS(ON)} < 1.3m\ \Omega @ V_{GS}=10V$  (Typ:  $1m\ \Omega$ )
- 2) Low gate charge.
- 3) Green device available.
- 4) Advanced high cell density trench technology for ultra low  $R_{DS(ON)}$ .
- 5) Excellent package for good heat dissipation.
- 6) MSL3

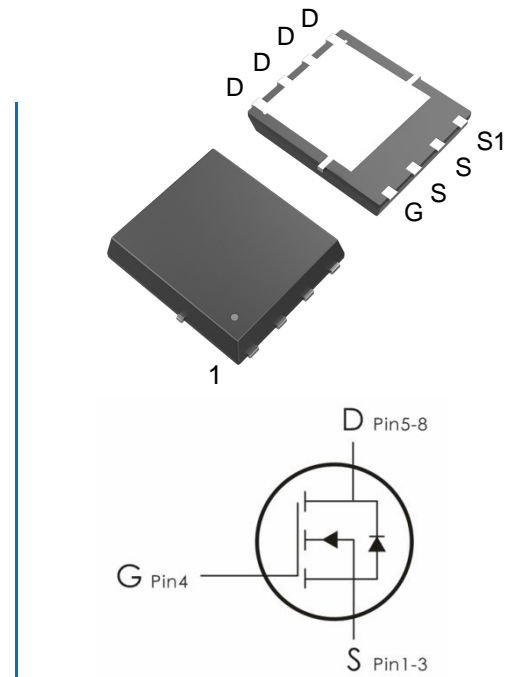

## Package Marking and Ordering Information:

Part NO.	Marking	Package	Packing
DON210N03T	210N03T	DFN5*6-8-Clip	5000 pcs/Reel

## Absolute Maximum Ratings: ( $T_C=25^\circ\text{C}$ unless otherwise noted)

Symbol	Parameter	Ratings	Units
$V_{DS}$	Drain-Source Voltage	30	V
$V_{GS}$	Gate-Source Voltage	$\pm 20$	V
$I_D$	Continuous Drain Current	210	A
	Continuous Drain Current- $T_C=100^\circ\text{C}$	147	
$I_{DM}$	Pulsed Drain Current <sup>1</sup>	840	
$P_D$	Power Dissipation	104	W
$E_{AS}$	Single pulse avalanche energy <sup>2</sup>	225	mJ
$T_J, T_{STG}$	Operating and Storage Junction Temperature Range	-55-+150	$^\circ\text{C}$

## Thermal Characteristics:

Symbol	Parameter	Max	Units
$R_{\theta JC}$	Thermal Resistance, Junction to Case	1.2	$^\circ\text{C}/\text{W}$
$R_{\theta JA}$	Thermal Resistance, Junction to Ambient	50	$^\circ\text{C}/\text{W}$

**Electrical Characteristics:** ( $T_C=25^\circ\text{C}$  unless otherwise noted)

Symbol	Parameter	Conditions	Min	Typ	Max	Units
<b>Off Characteristics</b>						
$BV_{DSS}$	Drain-Source Breakdown Voltage	$V_{GS}=0V, I_D=250\ \mu A$	30	---	---	V
$I_{DSS}$	Zero Gate Voltage Drain Current	$V_{GS}=0V, V_{DS}=30V$	---	---	1	$\mu A$
$I_{GSS}$	Gate-Source Leakage Current	$V_{GS}=\pm 20V, V_{DS}=0A$	---	---	$\pm 100$	nA
<b>On Characteristics</b> <small>(Note3)</small>						
$V_{GS(th)}$	Gate-Source Threshold Voltage	$V_{GS}=V_{DS}, I_D=250\ \mu A$	1	1.5	2.5	V
$R_{DS(on)}$	Drain-Source On Resistance <sup>3</sup>	$V_{GS}=10V, I_D=20A$	---	1	1.3	m $\Omega$
		$V_{GS}=4.5V, I_D=10A$	---	1.65	2.1	
<b>Dynamic Characteristics</b>						
$C_{iss}$	Input Capacitance	$V_{DS}=15V, V_{GS}=0V, f=1MHz$	---	2637	---	pF
$C_{oss}$	Output Capacitance		---	1265	--	
$C_{rss}$	Reverse Transfer Capacitance		---	77	---	
<b>Switching Characteristics</b>						
$t_{d(on)}$	Turn-On Delay Time	$V_{DS}=20V, I_D=30A,$ $R_G=1.6\ \Omega, V_{GS}=10V$	---	16	---	ns
$t_r$	Rise Time		---	3.8	---	ns
$t_{d(off)}$	Turn-Off Delay Time		---	49.8	---	ns
$t_f$	Fall Time		---	10.4	---	ns
$Q_g$	Total Gate Charge		$V_{GS}=10V, V_{DS}=20V,$ $I_D=30A$	---	39.8	---
$Q_{gs}$	Gate-Source Charge	---		7.5	---	nC
$Q_{gd}$	Gate-Drain "Miller" Charge	---		5.5	---	nC
<b>Drain-Source Diode Characteristics</b>						
$V_{SD}$	Diode Forward Voltage	$V_{GS}=0V, I_{SD}=30A$	---	---	1.2	V
$I_S$	Continuous Drain Current	$V_D=V_G=0V$	---	---	210	A
$I_{SM}$	Pulsed Drain Current		---	---	840	A
$T_{rr}$	Reverse Recovery Time	$I_F=30A, T_J=25^\circ\text{C}$	---	85	---	ns
$Q_{rr}$	Reverse Recovery Charge	$dI/dt=100A/\mu s$	---	34	---	nC

### Notes:

1. Repetitive Rating: Pulse Width Limited by Maximum Junction Temperature
2. EAS condition :  $T_J=25^{\circ}\text{C}$ ,  $V_{DD}=15\text{V}$ ,  $V_G=10\text{V}$ ,  $L=0.5\text{mH}$
3. Pulse Test: Pulse Width  $\leq 300\mu\text{s}$ , Duty Cycle  $\leq 0.5\%$

### Typical Characteristics: ( $T_C=25^{\circ}\text{C}$ unless otherwise noted)

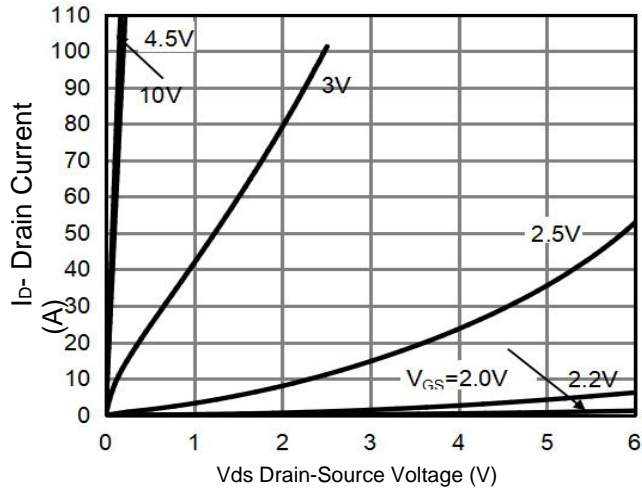

Fig 1: Output Characteristics

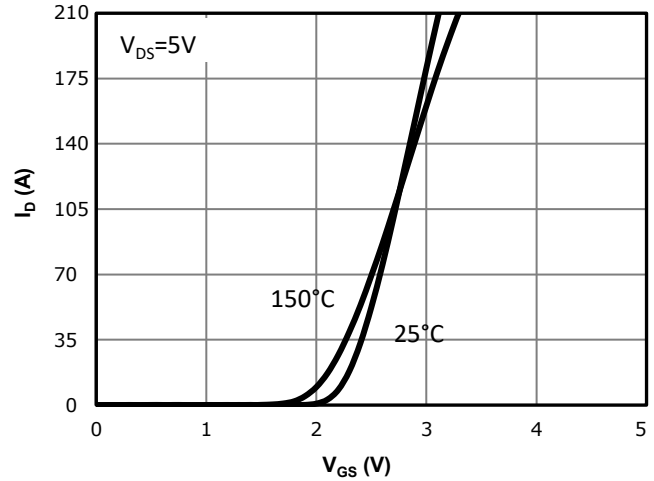

Fig 2: Transfer Characteristics

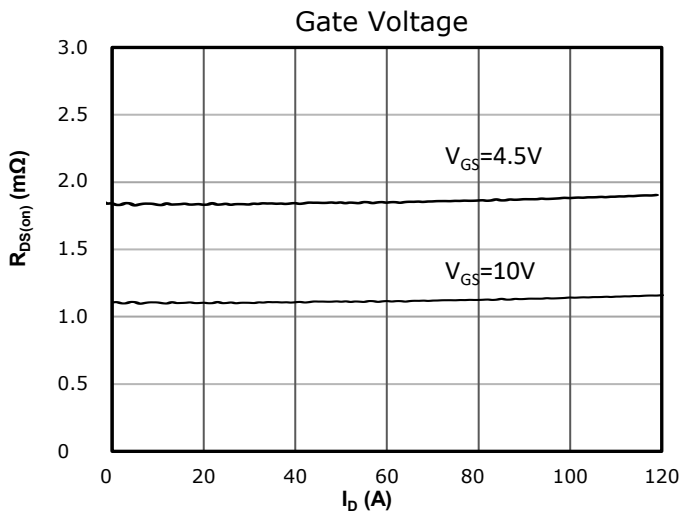

Fig 3:  $R_{ds(on)}$  vs Drain Current and Gate Voltage

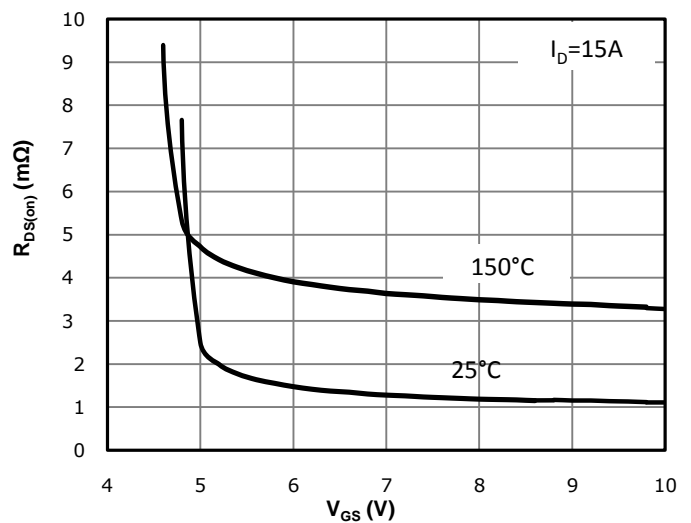

Fig 4:  $R_{ds(on)}$  vs Gate Voltage

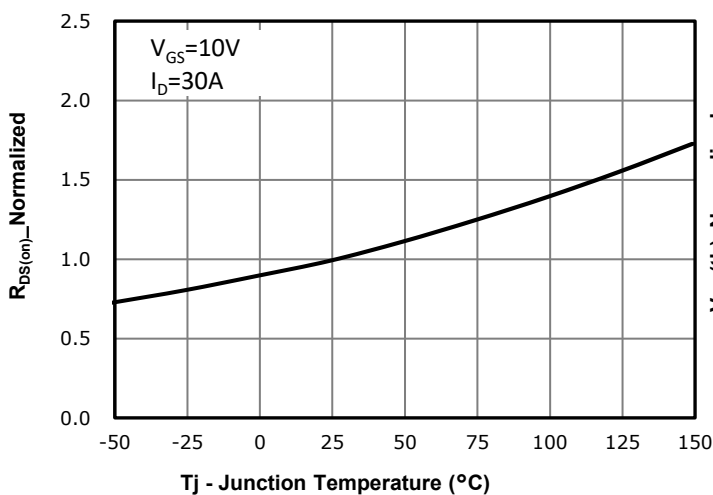

Fig 5:  $R_{ds(on)}$  vs. Temperature

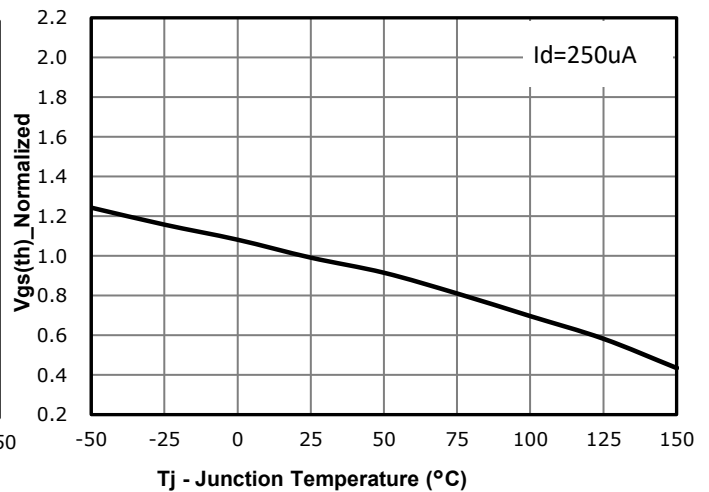

Fig 6:  $V_{gs(th)}$  vs. Temperature

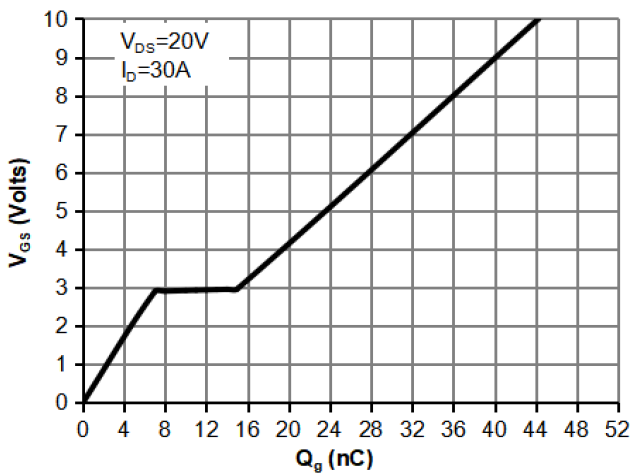

Fig 7: Gate Charge Characteristics

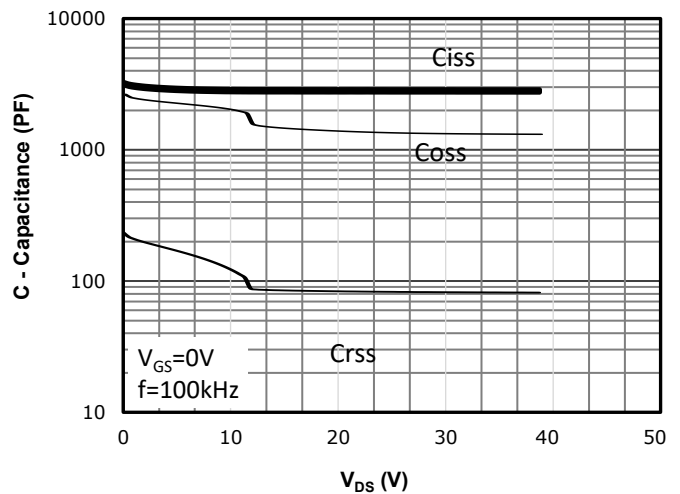

Fig 8: Capacitance Characteristics

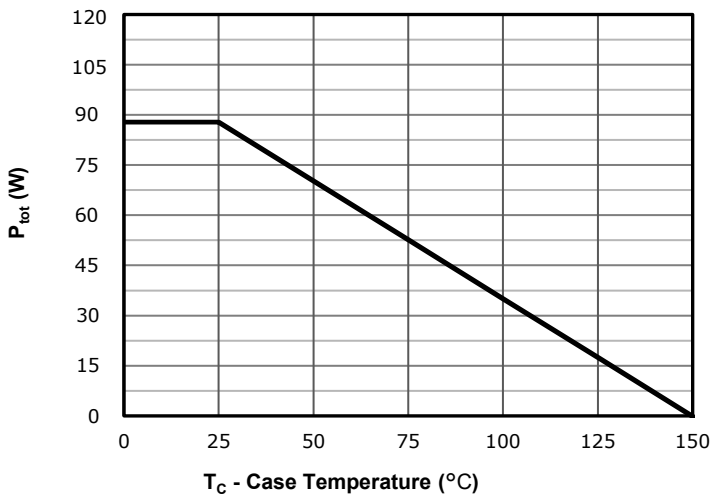

Fig 9: Power Dissipation

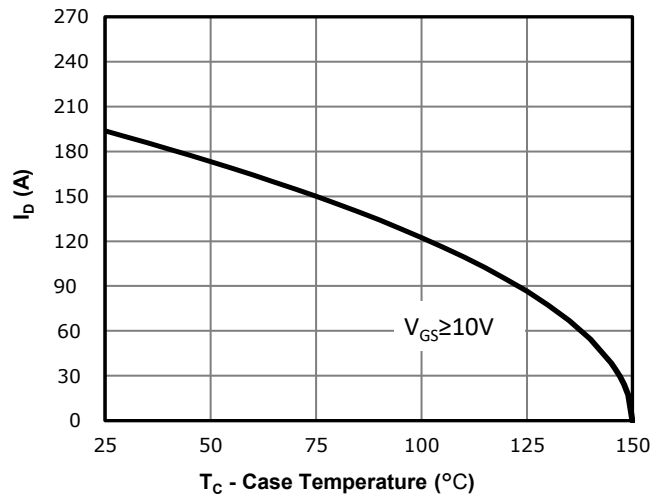

Fig 10: Drain Current Derating

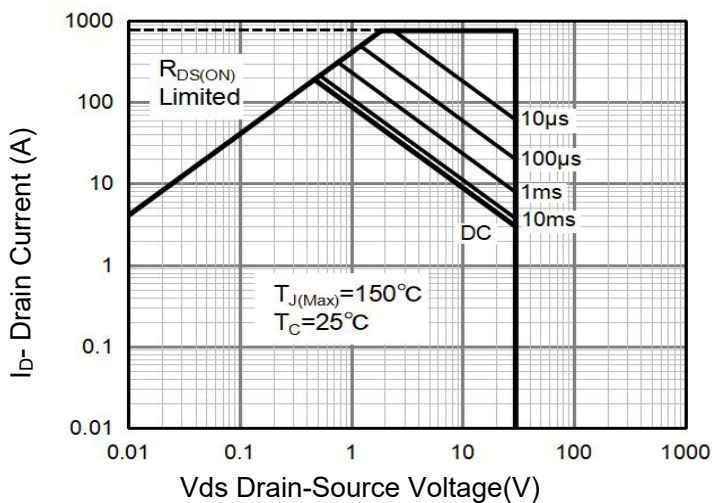
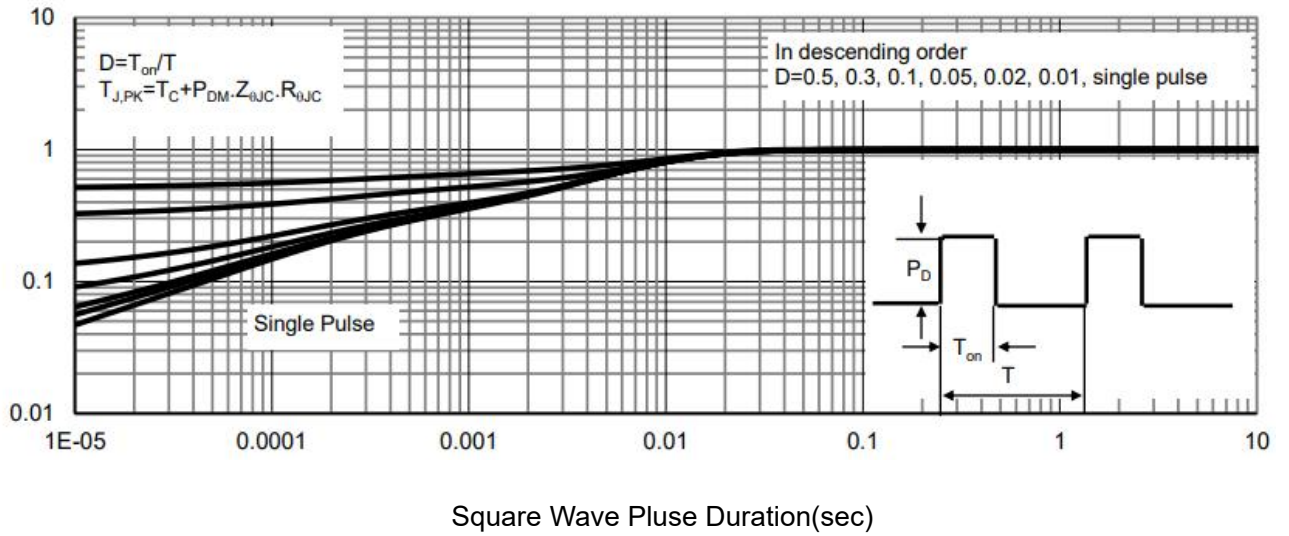
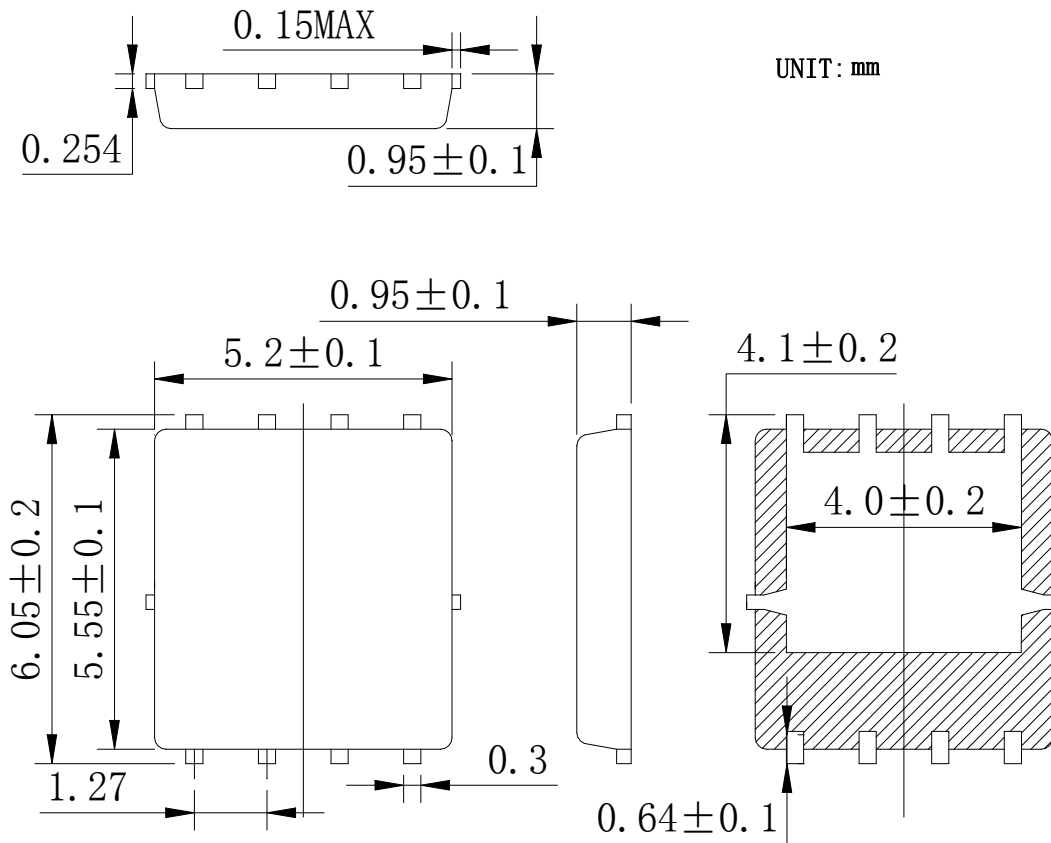

Figure 11 Safe Operation Area



**Figure 12 Normalized Maximum Transient Thermal Impedance**

## DFN5x6-8 Package Information:



## Tape & Reel Information

Dimensions in mm

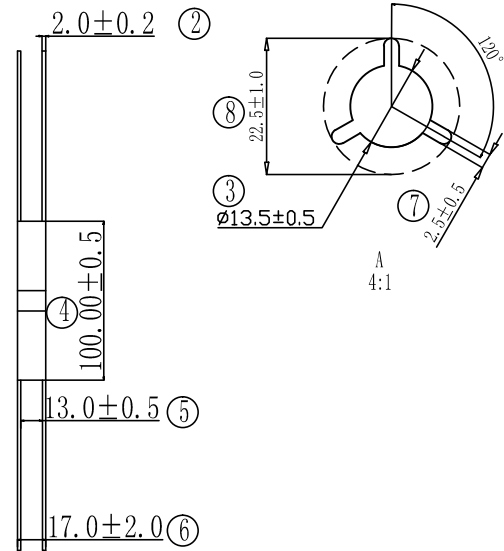
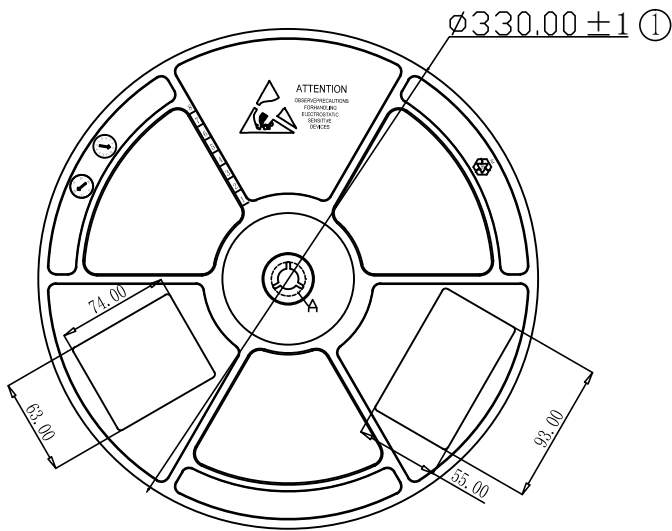

Symbol	A0	B0	K0	D0	D1	P0	P1	10*P0
Spec	$6.15 \pm 0.10$	$5.40 \pm 0.10$	$1.30 \pm 0.10$	$1.55 \pm 0.10$	$1.55 \pm 0.10$	$4.00 \pm 0.10$	$8.00 \pm 0.10$	$40.00 \pm 0.10$
Symbol	W	E	F	P2	t			
Spec	$12.00 \pm 0.10$	$1.75 \pm 0.10$	$5.50 \pm 0.10$	$2.00 \pm 0.10$	$0.20 \pm 0.05$			

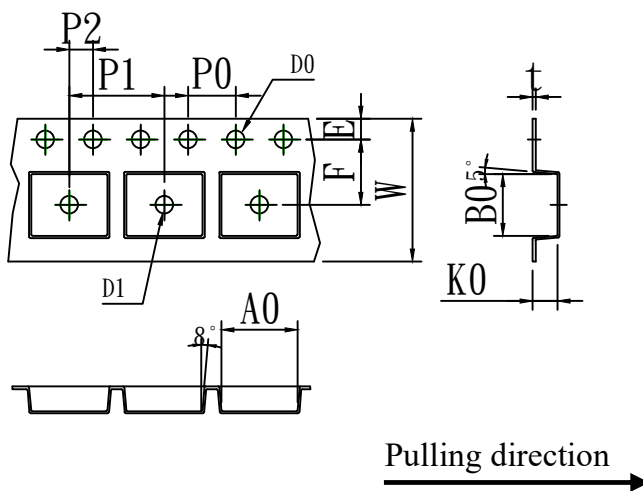

## Marking Information:

- ①. Doingter LOGO
- ②. Part NO.
- ③. Date Code(YWWG / R)

Y : Year Code , last digit of the year

WW : Week Code(01-53)

G/R : G(Green) /R(Lead Free)

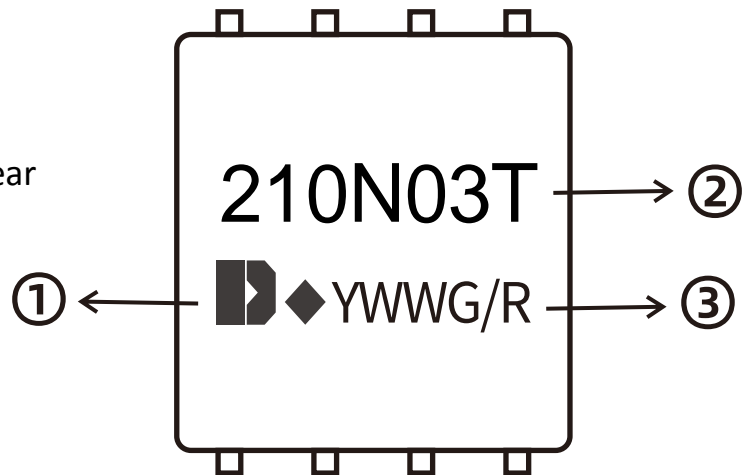

## Previous Version

Version	Date	Subjects (major changes since last revision)
1.0	2024-11-06	Release of final version

## Attention :

- Information furnished in this document is believed to be accurate and reliable. However, Shenzhen Doingter Semiconductor Co.,Ltd. assumes no responsibility for the consequences of use without consideration for such information nor use beyond it.
- Information mentioned in this document is subject to change without notice, apart from that when an agreement is signed, Shenzhen Doingter complies with the agreement. Products and information provided in this document have no infringement of patents.
- Shenzhen Doingter assumes no responsibility for any infringement of other rights of third parties which may result from the use of such products and information. This document supersedes and replaces all information previously supplied.  Is

a registered trademark of Shenzhen Doingter Semiconductor Co., Ltd. Copyright © 2013

Shenzhen Doingter Semiconductor Co.,Ltd. Printed All rights reserved.