

REVISIONS				
P	LTR	DESCRIPTION	DATE	APVD
	A	INITIAL RELEASE	10SEP2023	J.S Z.Z
	A1	ECN-24-290823	29OCT2024	J.S Z.Z

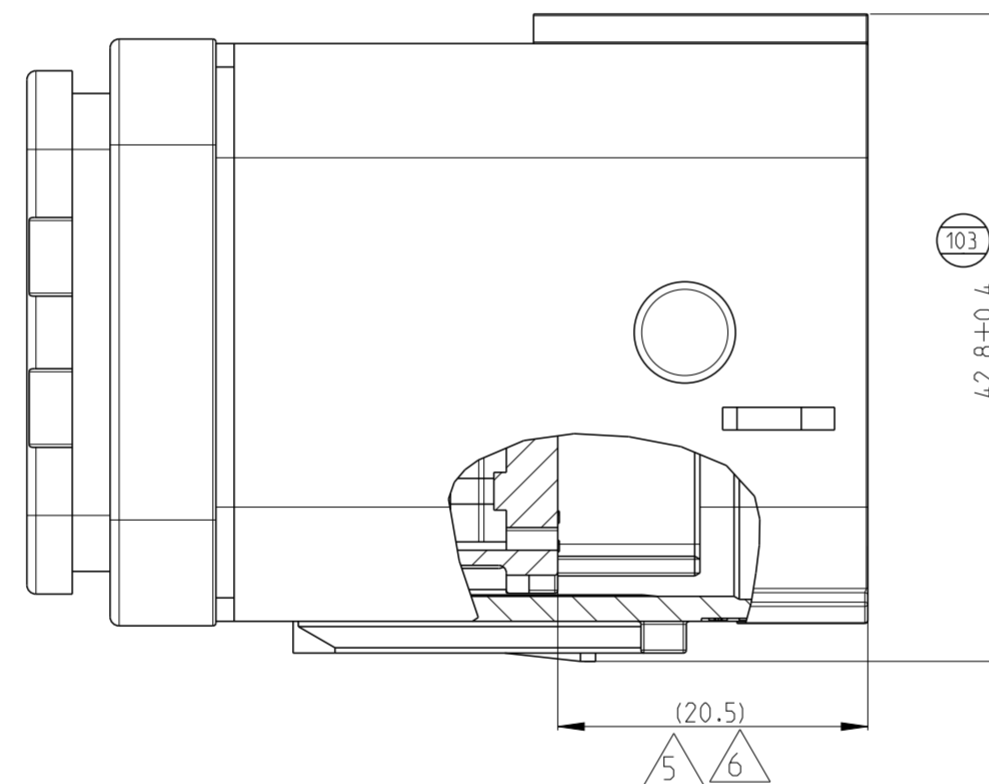
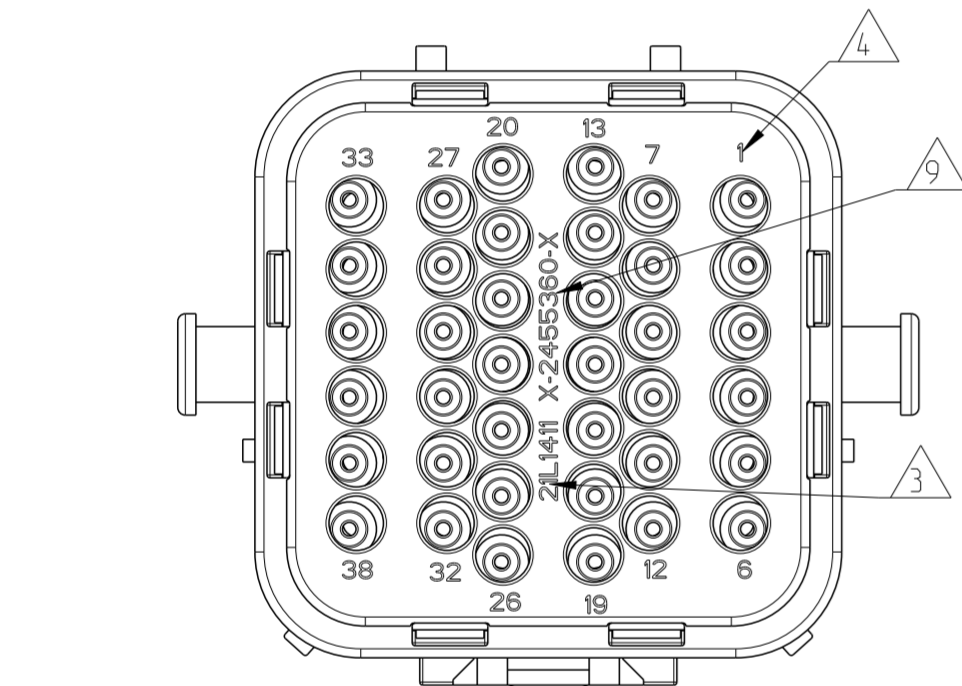

NOTE:

- 1. THIS REC HSG ASSEMBLY MATES WITH PLUG ASSEMBLY PN 2455359-X (X=1, 2, 3, 4 FOR VARIOUS CODE).
- 2. FOR FLANGE VERSION. NEED MATE WITH FIX RING PN 2366517-X.SEE DRAWING 2366517 FOR APPLICABLE WALL THICKNESS.
- 3. DATE CODE: IDENTIFIES THE YEAR, MONTH, DAY AND HOUR OF ASSEMBLY.
YEAR: FIRST AND SECOND DIGITS(21=2021)
MONTH: THIRD DIGIT , EXCLUDING 1 , A=JAN, B=FEB, C=MARCH...(M=DECEMBER)
DAY: FOURTH AND FIFTH DIGITS(14=14th DAY)
HOUR: SIXTH AND SEVENTH DIGITS(11=11AM)
- 4. IDENTIFICATION FOR CABLE PINOUT.
- 5. TPA SEATED ON PRE-LOCK POSITION FOR DELIVERY.
- 6. PULL TPA TO PRE-LOCK BEFORE TERMINAL INSERTION IN CASE OF TPA BEING HIT TO END-LOCK POSITION.
- 7. REFER TO 114-151001 FOR DT SIZE 16 TERMINAL APPLICATION SPECIFICATION.
APPLICABLE TERMINAL PART NUMBERS AND WIRE SIZE:

TERMINAL PN	WIRE SIZE (MM2)	INSULATION WIRE (MM)	PINOUT NUMBER
16#	0.75-2.5	∅1.7-∅3.0	ALL

- 8. FOR FLANGE VERSION THE FACIAL SEAL SEATED IN THE RIGHG POSITION WITH CORRECT DIRECTION.
- 9. LASER PRODUCT PN. SUCH AS "--1"MEANS 2455360-1, "1--1" MEANS 1-2455360-1.

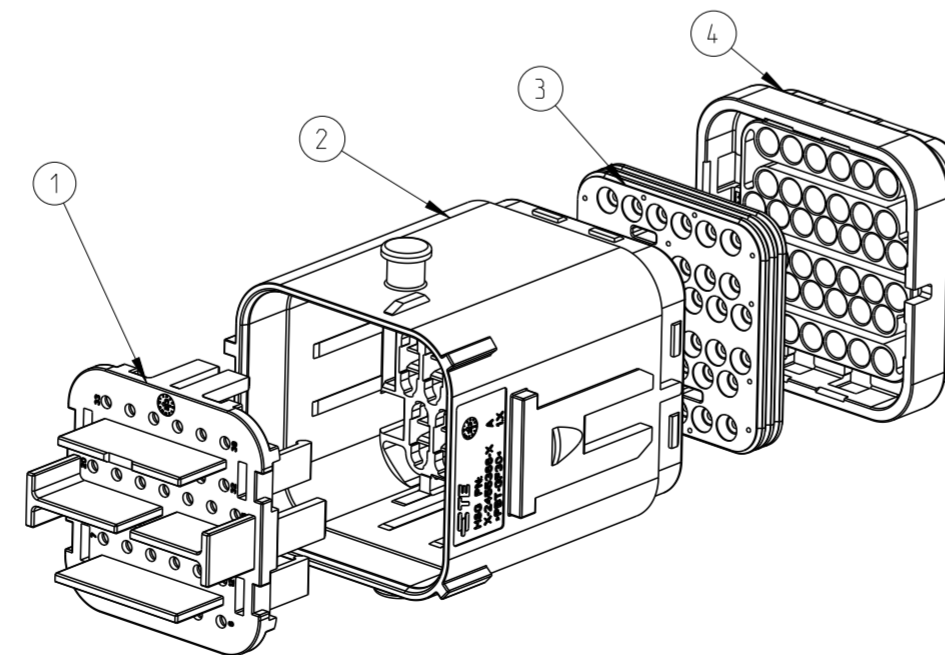
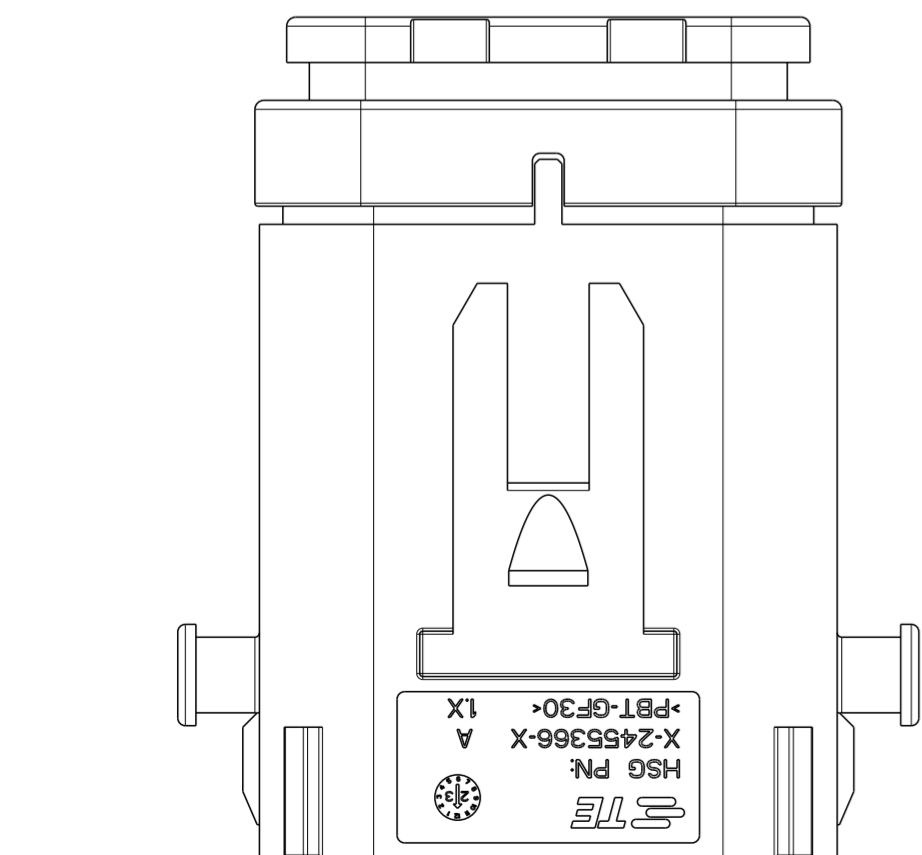

1	-	-	-	BLUE	PBT-GF30	REAR CAP	4			
-	1	-	-	GREEN						
-	-	1	-	GREY						
-	-	-	1	BLACK	VMQ	FAMILY SEAL	3			
1	1	1	1	RUST RED						
-	1	-	-	BLUE				PBT-GF30	HOUSING CODING D	2
-	-	-	-	GREEN						
-	-	1	-	GREY	HOUSING CODING B					
-	-	-	1	BLACK	PBT-GF30	TPA	1			
1	1	1	1	YELLOW						
QTY. REQUEST PER ASSY				COLOR	MATERIAL	DESCRIPTION	ITEM NO			
A	A	A	A	REVISION OF EACH ASSY PN						
--4	--3	--2	--1	TE ASSEMBLY PN						

THIS DRAWING IS A CONTROLLED DOCUMENT.

DIMENSIONS:	TOLERANCES UNLESS OTHERWISE SPECIFIED:
mm	
0 PLC	±
1 PLC	±
2 PLC	±
3 PLC	±
4 PLC	±
ANGLES	±
FINISH	-

DWN	J.SHANG	10SEP2023	 TE Connectivity	NAME NTS 38P REC HSG ASSEMBLY		
CHK	C.WAN	10SEP2023				
APVD	Z.ZHOU	10SEP2023				
PRODUCT SPEC	108-101662					
APPLICATION SPEC	114-32209		SIZE	CAGE CODE	DRAWING NO	RESTRICTED TO
WEIGHT	-		A2	00779	C-2455360	-
CUSTOMER DRAWING	SCALE 1:1		SHEET 1 OF 2	REV A1		

P	LTR	DESCRIPTION	DATE	DWN	APVD
		SEE SHEET 1			

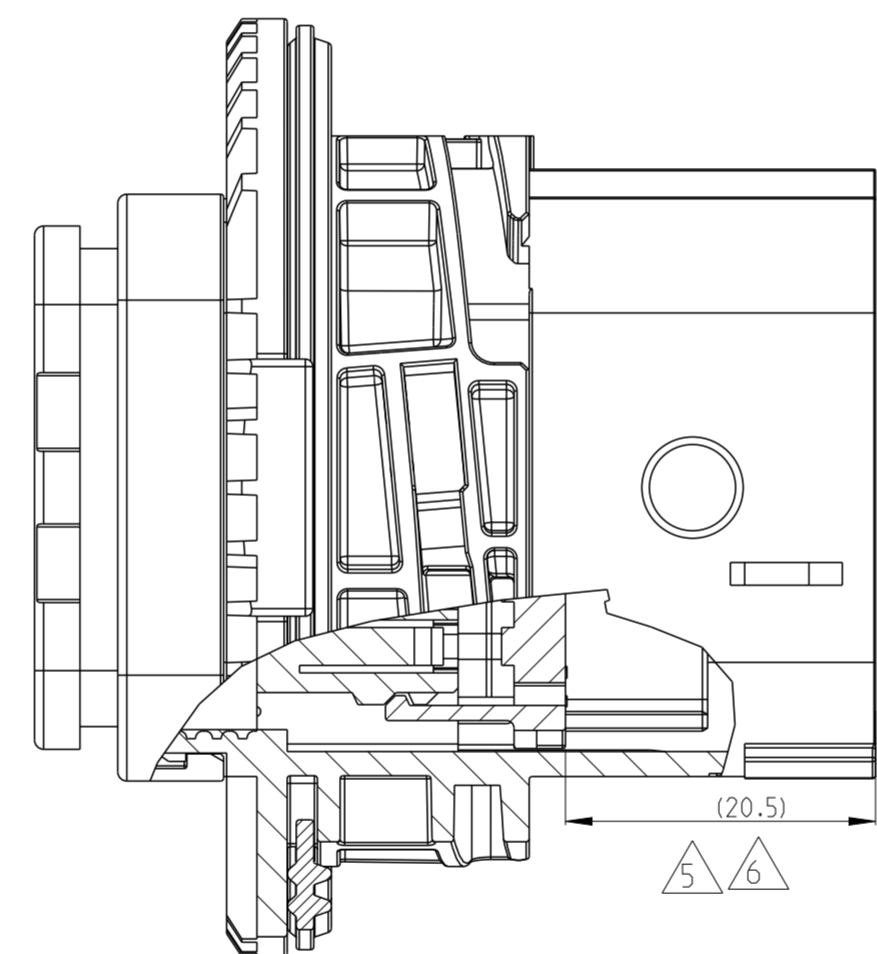
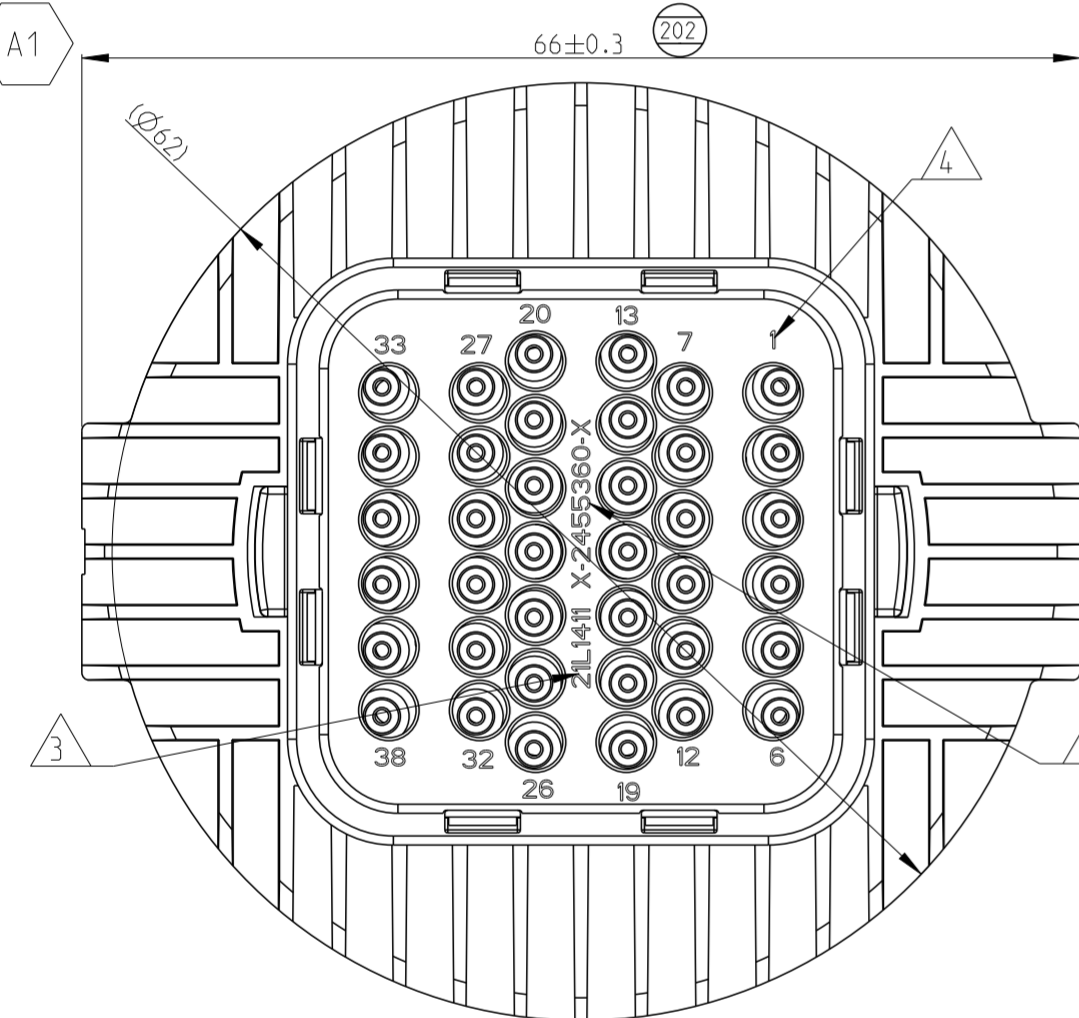
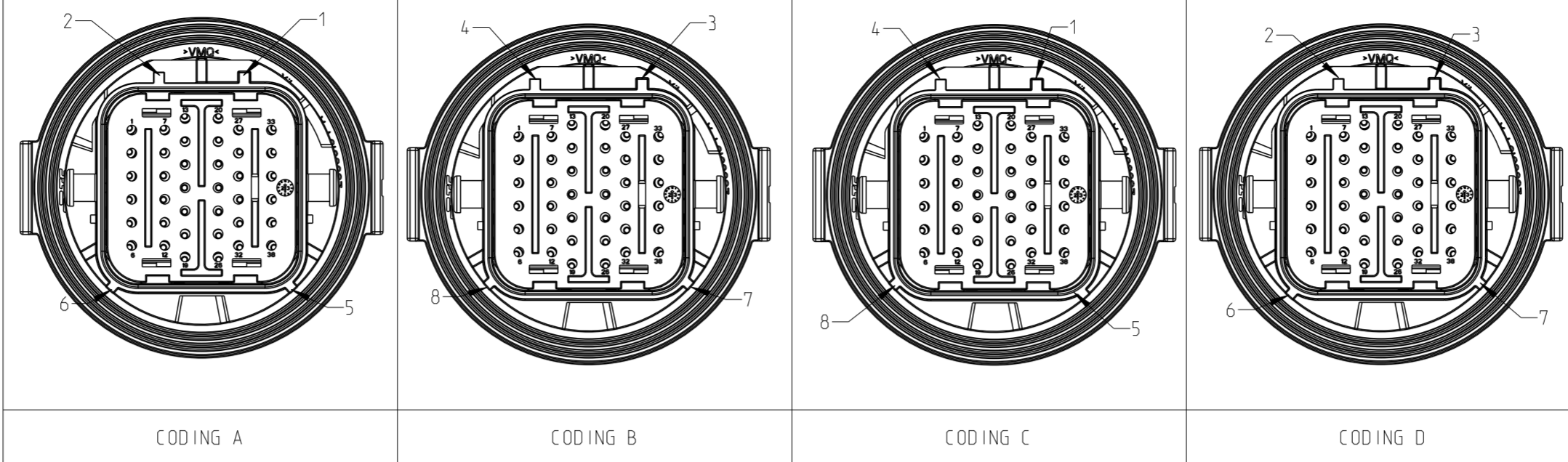
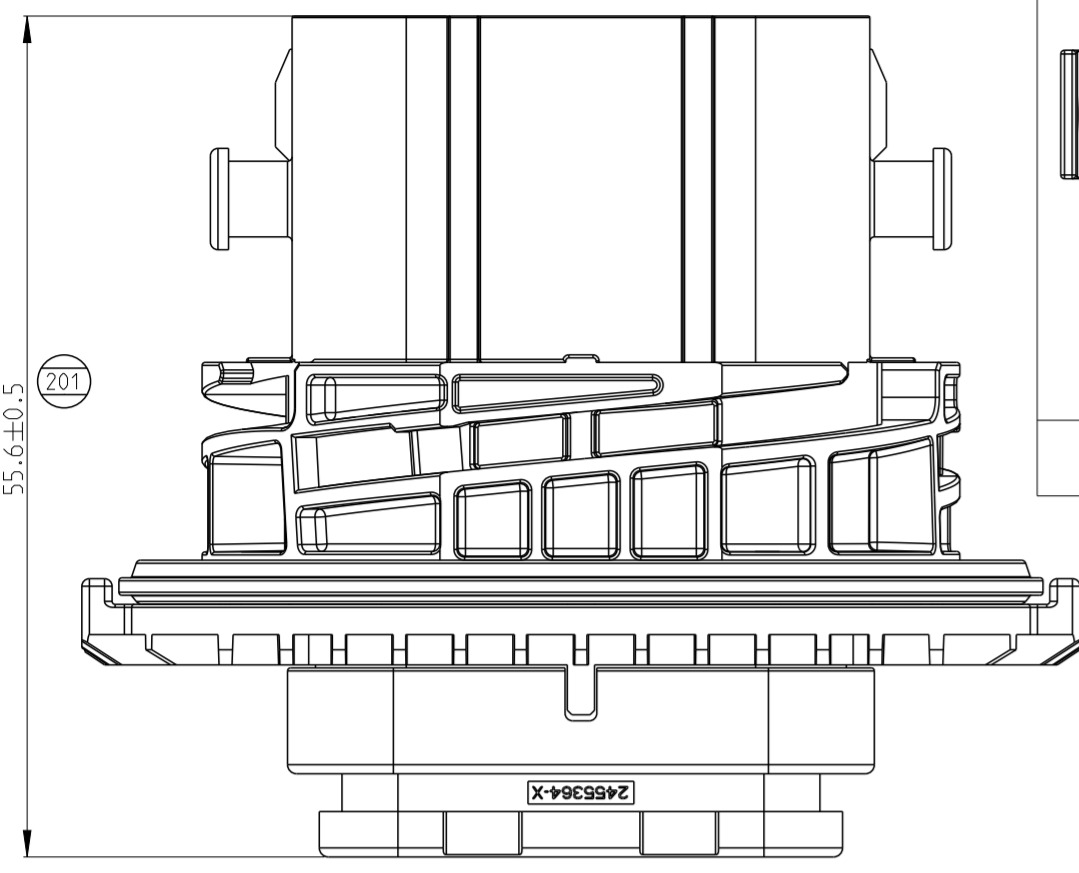

10. FOR FLANGE VERSION 1-2455360-1/2/3/4, THE RECOMMENDED FIX RING AND PANEL CUTOUT DIMENSIONS REFER TO C-DRAWING 2366517.

WALL THICKNESS DIM A(MM)	PN OF FIX RING
4.0	2366517-4
3.5	2366517-3
3.0	2366517-2
1.5	2366517-1

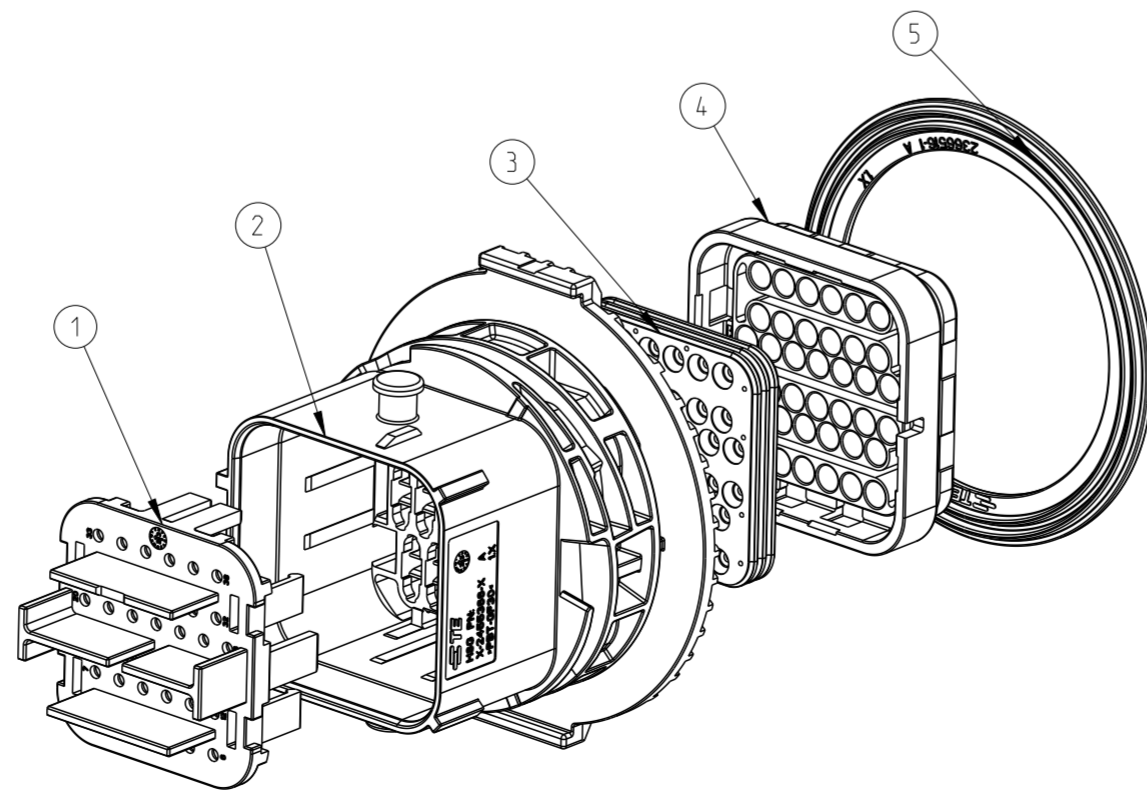
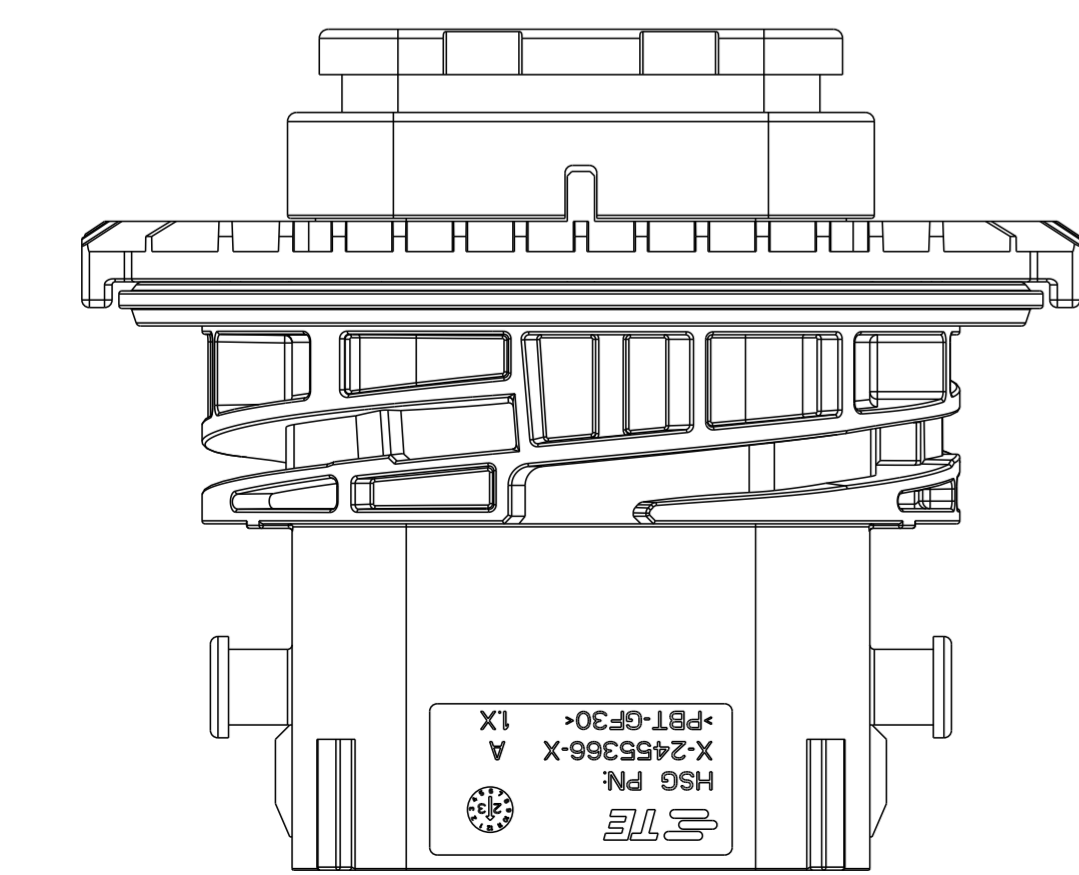

QTY.	REQUEST PER ASSY	COLOR	MATERIAL	DESCRIPTION	ITEM NO
1	1	RUST RED	VMQ	FACIAL SEAL	5
1	-	BLUE	PBT-GF30	REAR CAP	4
-	1	GREEN			
-	-	GREY			
-	-	BLACK			
1	1	RUST RED	VMQ	GROMMET	3
1	-	BLUE	PBT-GF30	HOUSING CODING D	2
-	1	GREEN		HOUSING CODING C	
-	-	GREY		HOUSING CODING B	
-	-	BLACK		HOUSING CODING A	
1	1	YELLOW	PBT-GF30	TPA	1
QTY. REQUEST PER ASSY				REVISION OF EACH ASSY PN	ITEM NO
1--4	1--3	1--2	1--1	TE ASSEMBLY PN	

THIS DRAWING IS A CONTROLLED DOCUMENT.

DIMENSIONS:	TOLERANCES UNLESS OTHERWISE SPECIFIED:	DWN	J. SHANG	10SEP2023	TE Connectivity NTS 38P REC HSG ASSEMBLY			
mm	0 PLC ±	CHK	C. WAN	10SEP2023				
	1 PLC ±	APVD	Z. ZHOU	10SEP2023				
	2 PLC ±	PRODUCT SPEC		108-101662				
	3 PLC ±	APPLICATION SPEC		114-32209	SIZE	CAGE CODE	DRAWING NO	RESTRICTED TO
	4 PLC ±	WEIGHT		-	A2	00779	C-2455360	-
MATERIAL	ANGLES ±	CUSTOMER DRAWING			SCALE	1:1	SHEET	2 OF 2
	FINISH -				REV	A1		