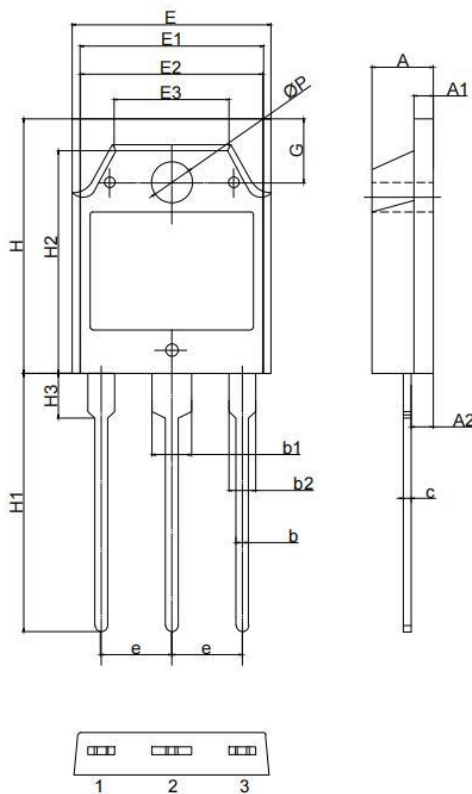
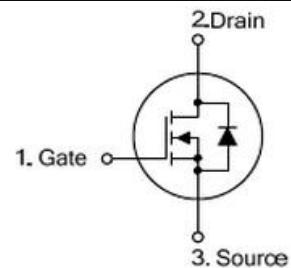
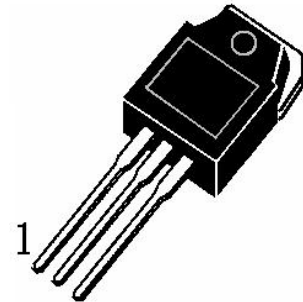

◆ Features:

- ◇ Fast switching speed
开关速度快
- ◇ High input impedance and low level drive
高输入阻抗和低电平驱动
- ◇ Avalanche energy tested
雪崩能量测试
- ◇ Improved dv/dt capability, high ruggedness
提高 dv/dt 能力, 高耐用性

◆ Applications

- ◇ High efficiency switch mode power supplies
高效率开关电源
- ◇ Power factor correction
功率因数校正
- ◇ Electronic lamp ballast
电子整流器

TO-3PN

TO-3PNB尺寸表/mm			
Symbol	Min	Nom	Max
A	4.60	4.80	5.00
A1	1.30	1.50	1.60
A2	1.40	1.50	1.60
b	0.80	1.00	1.20
b1	2.90	3.10	3.30
b2	1.90	2.10	2.30
c	0.50	0.60	0.70
e	5.25	5.45	5.65
E	15.20	15.60	16.00
E1	13.20	13.40	13.60
E2	13.10	13.50	13.50
E3	9.10	9.30	9.50
H	19.80	20.00	20.20
H1	20.10	20.30	20.50
H2	18.50	18.70	18.90
H3	3.20	3.50	3.80
G	4.80	5.00	5.20
ØP	3.00	3.20	3.40

◆ Absolute Maximum Ratings (Tc=25°C)

Symbol	Parameters	Ratings	Unit
V _{DSS}	Drain-Source Voltage 漏源电压	650	V
V _{GS}	Gate-Source Voltage-Continuous 栅源电压	±30	V
I _D	Drain Current-Continuous (Note 2) 漏极持续电流	30	A
I _{DM}	Drain Current-Single Plused (Note 1) 漏极单次脉冲电流	120	A
P _D	Power Dissipation (Note 2) 功率损耗	330	W
T _j	Max.Operating junction temperature 最大结温	150	°C

◆ Electrical characteristics (Tc=25°C unless otherwise noted)

Symbol	Parameters	Min	Typ	Max	Units	Conditions
Static Characteristics						
B _{VDSS}	Drain-Source Breakdown VoltageCurrent (Note 1) 漏极击穿电压	650	--	--	mA	I _D =250μA, V _{GS} =0V, T _J =25°C
V _{GS(th)}	Gate Threshold Voltage 栅极开启电压	2.0	--	4.0	V	V _{DS} =V _{GS} , I _D =250μA
R _{DS(on)}	Drain-Source On-Resistance 漏源导通电阻	--	0.25	--	Ω	V _{GS} =10V, I _D =1A
I _{GSS}	Gate-Body Leakage Current 栅极漏电流	--	--	±100	nA	V _{GS} =±30V, V _{DS} =0
I _{DSS}	Zero Gate Voltage Drain Current 零栅极电压漏极电流	--	--	1	μA	V _{DS} =650V, V _{GS} =0
g _{fs}	Forward Transconductance 正向跨导	12.0	--	--	S	V _{DS} =50V, I _D =15A

Switching Characteristics						
$T_{d(on)}$	Turn-On Delay Time 开启延迟时间	--	55	--	ns	$V_{DS}=380V, I_D=15A,$ $R_G=4.7\Omega$ (Note 2)
T_r	Rise Time 上升时间	--	10	--	ns	
$T_{d(off)}$	Turn-Off Delay Time 关闭延迟时间	--	20	--	ns	
T_f	Fall Time 下降时间	--	10	--	ns	
Q_g	Total Gate Charge 栅极总电荷	--	60	--	nC	$V_{DS}=500V$, $V_{GS}=10V,$ $I_D=30A$ (Note 2)
Q_{gs}	Gate-Source Charge 栅源极电荷	--	15	--	nC	
Q_{gd}	Gate-Drain Charge 栅漏极电荷	--	25	--	nC	
Dynamic Characteristics						
C_{iss}	Input Capacitance 输入电容	--	5500	--	pF	$V_{DS}=25V, V_{GS}=0,$ $f=1MHz$
C_{oss}	Output Capacitance 输出电容	--	385	--	pF	
C_{rss}	Reverse Transfer Capacitance 反向传输电容	--	30	--	pF	
I_S	Continuous Drain-Source Diode Forward Current (Note 2) 二极管导通正向持续电流	--	--	30	A	
V_{SD}	Diode Forward On-Voltage 二极管正向导通电压	--	--	1.4	V	$I_S=15A, V_{GS}=0$
$R_{th(j-c)}$	Thermal Resistance, Junction to Case 结到外壳的热阻	--	--	0.38	$^{\circ}C/W$	

Note 1: Repetitive Rating : Pulse width limited by maximum junction temperature

Note 2: Pulse test: PW \leq 300us , duty cycle \leq 2%.