

Low Noise, Low Power, Low Temperature Drift, 40 V Precise Voltage Reference

Features

- Low Temperature Drift: 3 ppm/°C max
- High Accuracy: $\pm 0.05\%$ max
- Multiple Output Voltage: 2.048 V, 2.5 V, 3 V, 3.3 V, 4.096 V, 5 V, 10 V
- Low Noise: 0.1 Hz to 10 Hz, 2.1 ppm_{P-P}
- Strong driving capability: 20 mA
- Wide Supply Range: 2.8 V or $V_{OUT} + 0.3$ V to 40 V
- Low Quiescent Current: 160 μ A
- Wide Temperature Range: -40 °C to +125 °C

Application

- Precision Data Acquisition
- Precision Instruments
- Industrial Control
- Optical Communication
- Smart Grid

Typical Application

ADRXXX as ADC voltage Reference

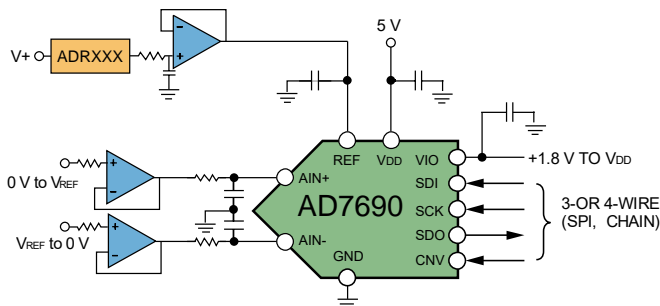

Typical Characteristics

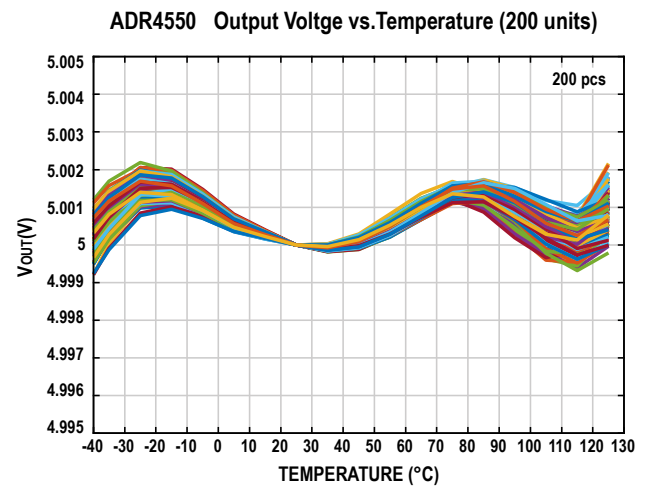

Pin Configurations and Function Descriptions

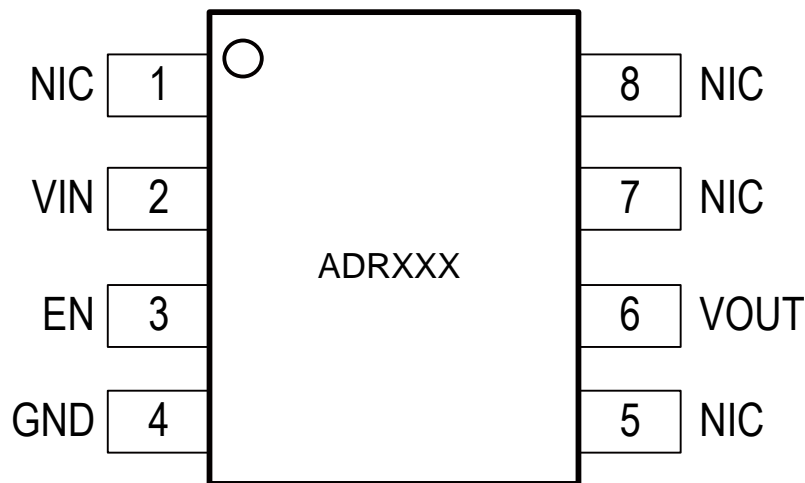

Figure 1. ADRXXX Pin Configuration (8-lead SOIC and MSOP)

Mnemonic	Pin No.	I/O ¹	Description
NIC	1,5,7,8	--	No Internal Connection
VIN	2	AI	Input Voltage
EN	3	AI	EN Input. This active low input powers down the device to 9 μ A. If left open, an internal pull-up resistor puts the part in normal operation. It is recommended to tie this pin high externally for best performance during normal operation.
GND	4	AI	Ground Pin = 0 V.
VOUT	6	AO	Output Voltage

Absolute Maximum Ratings

Parameter	Rating
Supply Voltage	40 V
Input Voltage	-0.2 V to 40 V
Output Short-Circuit Current to GND	±30 mA
Operating Temperature Range	-40 °C to +125 °C
Storage Temperature Range	-65 °C to +150 °C
Junction Temperature Range	-65 °C to +150 °C
Maximum Reflow Temperature	260 °C
Lead Temperature (Soldering, 10 sec)	300 °C
Electrostatic Discharge (ESD)	
Human Body Model (HBM)	4.5 kV
Charge Device Model (CDM)	2 kV

Thermal Resistance

Package Type	θ_{JA}	θ_{JC}	Unit
8-lead SOIC	158	43	°C/W
8-lead MSOP	190	44	°C/W

Specifications¹

The ● denotes the specification which apply over the full operating temperature range, otherwise specifications are at $V_{IN} = 2.8\text{ V}$ to 40 V , $I_{LOAD} = 0$, $C_L = 0.1\ \mu\text{F}$, $T_A = 25\ ^\circ\text{C}$, unless otherwise noted.

Parameter	Symbol	Conditions	Min	Typ.	Max	Unit
Output Voltage	V_{OUT}	ADR4520		2.048		V
		ADR431		2.5		V
		ADR443		3		V
		ADR4533		3.3		V
		ADR4540		4.096		V
		ADR4550		5		V
		AD581		10		V
Initial Accuracy			-0.05		+0.05	%
Temperature Coefficient						
C Grade			●	2.5	3	ppm/ $^\circ\text{C}$
B Grade			●	2.8	5	ppm/ $^\circ\text{C}$
B Grade, Temperature Grade E		0 $^\circ\text{C}$ to +75 $^\circ\text{C}$		3	5	ppm/ $^\circ\text{C}$
A Grade			●	3	8	ppm/ $^\circ\text{C}$
Voltage Noise		0.1 Hz to 10 Hz		2.1		ppm _{P-P}
Voltage Noise Density	e_n	ADR4520 1 kHz		167		nV/ $\sqrt{\text{Hz}}$
		ADR431 1 kHz		185		nV/ $\sqrt{\text{Hz}}$
		ADR443 1 kHz		225		nV/ $\sqrt{\text{Hz}}$
		ADR4533 1 kHz		233		nV/ $\sqrt{\text{Hz}}$
		ADR4540 1 kHz		348		nV/ $\sqrt{\text{Hz}}$
		ADR4550 1 kHz		380		nV/ $\sqrt{\text{Hz}}$
		AD581 1 kHz		774		nV/ $\sqrt{\text{Hz}}$
Line Regulation		ADR4520 : $V_{IN} = 2.8\text{ V} \sim 40\text{ V}$ Others: $V_{IN} = V_{OUT} + 0.3\text{ V} \sim 40\text{ V}$	●	0.1	3	ppm/V
Load Regulation		-10 mA < I_{LOAD} < 10 mA	●	0.8	20 35	ppm/mA
Supply Voltage	V_{IN}	$I_{LOAD} = 5\text{ mA}$ Output Voltage Error $\leq 0.1\%$				
		ADR4520	●	2.8	40	V
		Others	●	$V_{OUT}+0.3$	40	V

Parameter	Symbol	Conditions	Min	Typ.	Max	Unit
Supply Current	I _{SY}	No Load	•	160	200	μA
		SHUTDOWN (EN = GND)	•	10	20	μA
Shutdown Pin (EN)		Logic High Input Voltage	•	2		V
		Logic High Input Current	•	-1	1	μA
		Logic Low Input Voltage	•		0.8	V
		Logic Low Input Current	•	-1	1	μA
Output Short Circuit Current	I _{SC}	V _{OUT} = GND or V _{IN}	•	14	20	mA
Turn-on Time		0.1% settling, C _L = 0.1 μF		200		μs
Long-Term Stability ²	LTD	1000 hours, SOIC-8		15		ppm/1000 hours
		1000 hours, MSOP-8		10		ppm/1000 hours
Output Voltage Hysteresis		SOIC-8		50		ppm
		MSOP-8		50		ppm
Temperature Range		Specified Temperature Range		-40	125	°C
		Operating Temperature Range		-55	125	°C

Typical Performance Characteristics

At $V_{IN} = 2.8\text{ V to }40\text{ V}$, $I_{LOAD} = 0$, $C_L = 0.1\ \mu\text{F}$, $T_A = 25\ ^\circ\text{C}$, unless otherwise noted.

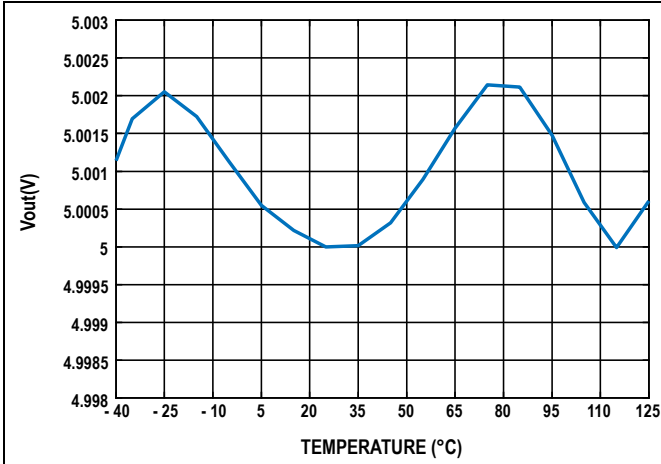

Figure 2. ADR4550 Output Voltage vs. Temperature (B Grade)

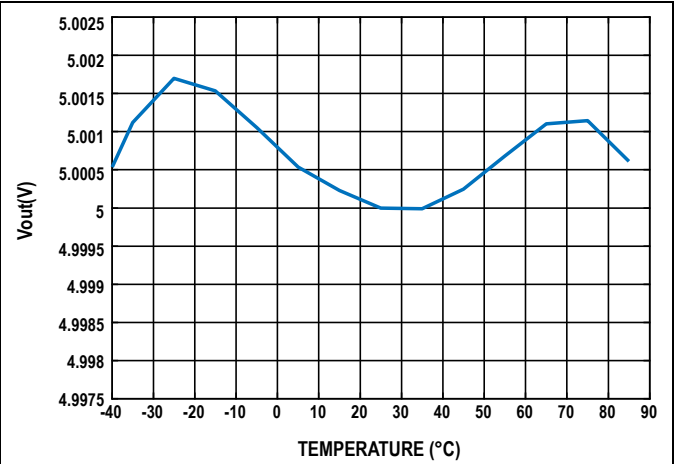

Figure 3. ADR4550 Output Voltage vs. Temperature (E Grade)

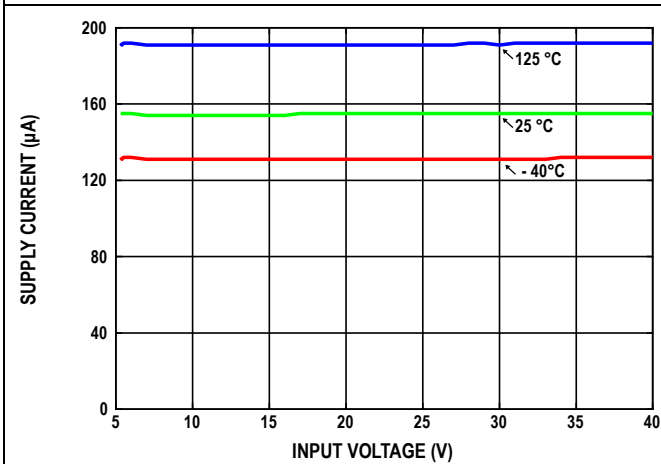

Figure 4. Supply Current vs. Input Voltage

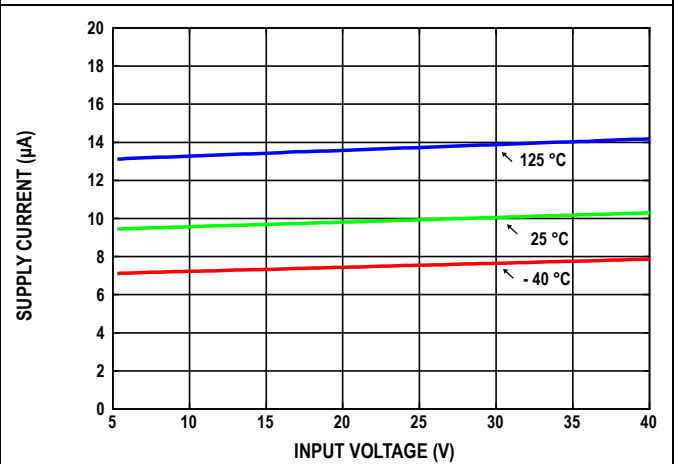

Figure 5. Supply Current vs. Input Voltage in SHUTDOWN mode

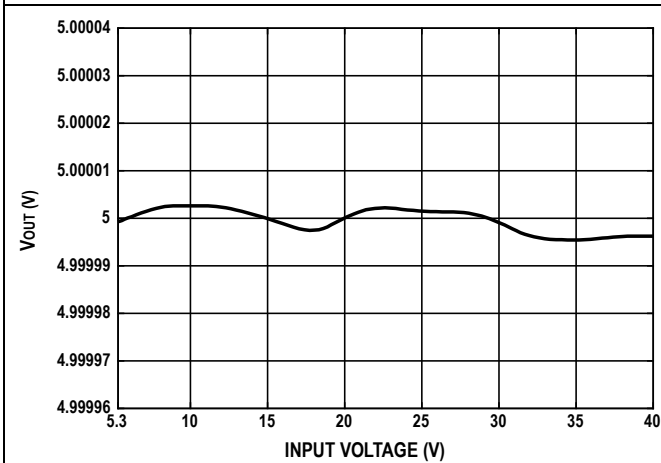

Figure 6. ADR4550 Line Regulation

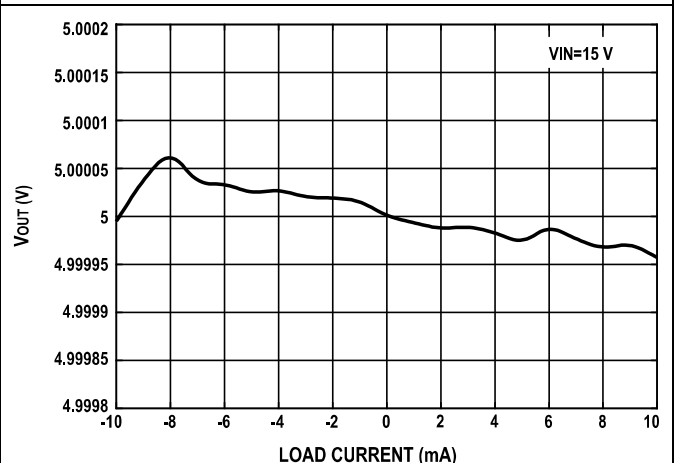
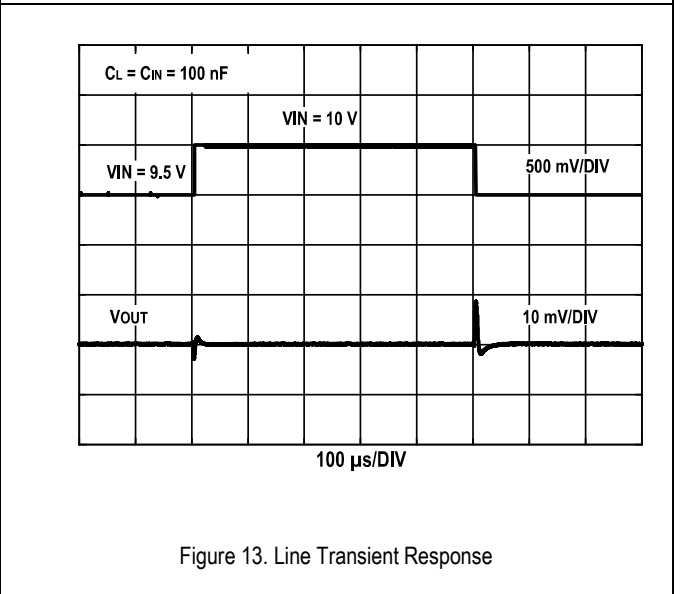
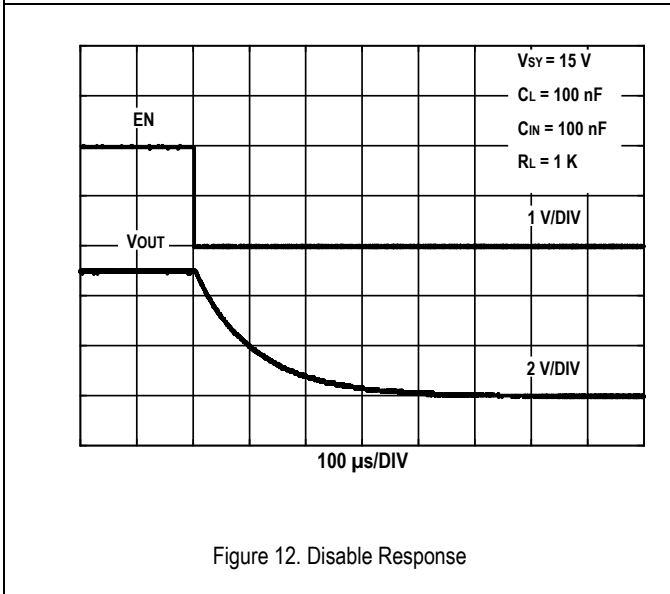
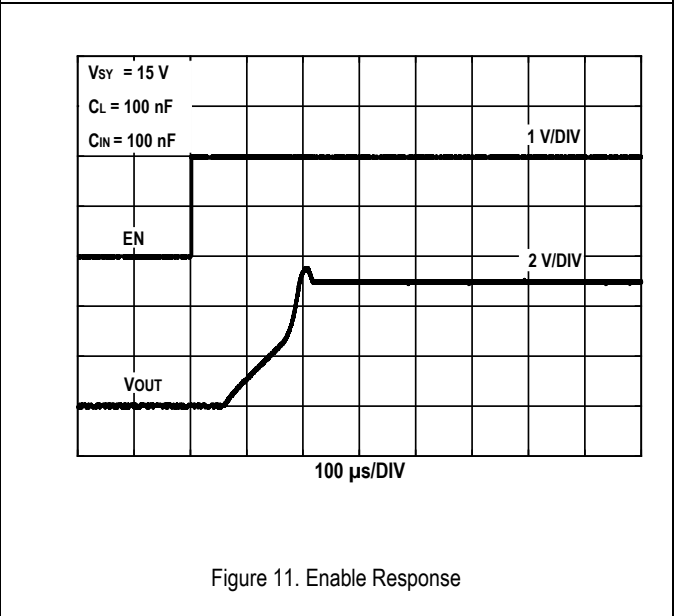
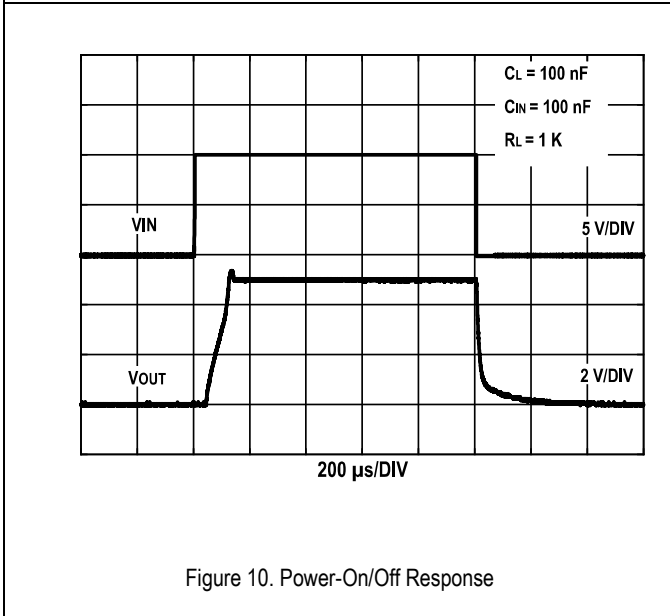
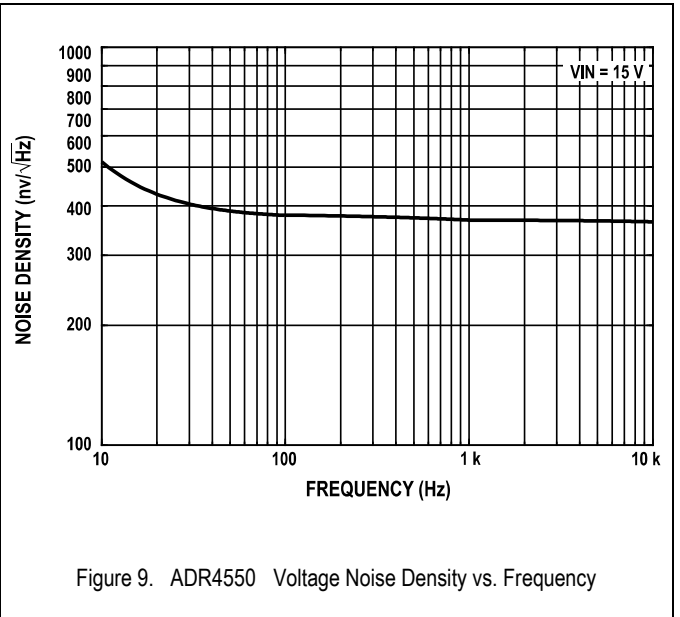
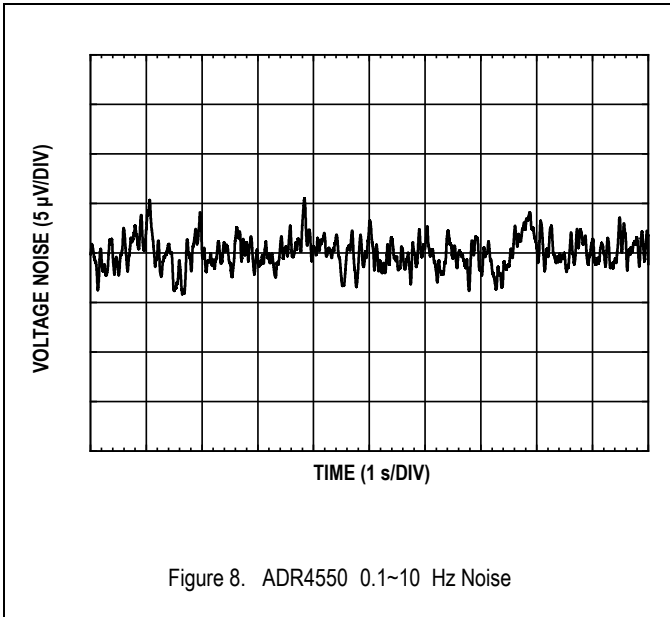

Figure 7. ADR4550 Load Regulation



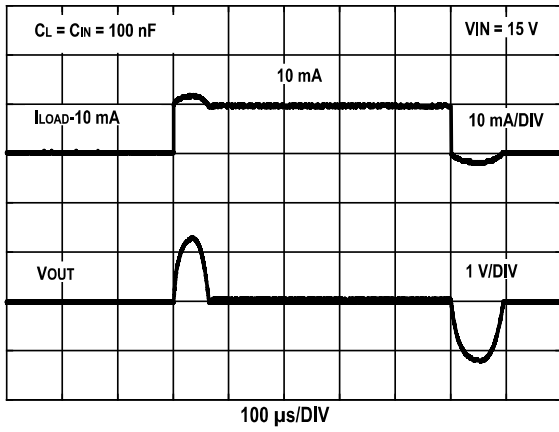

Figure 14. ADR4550 Load Transient Response

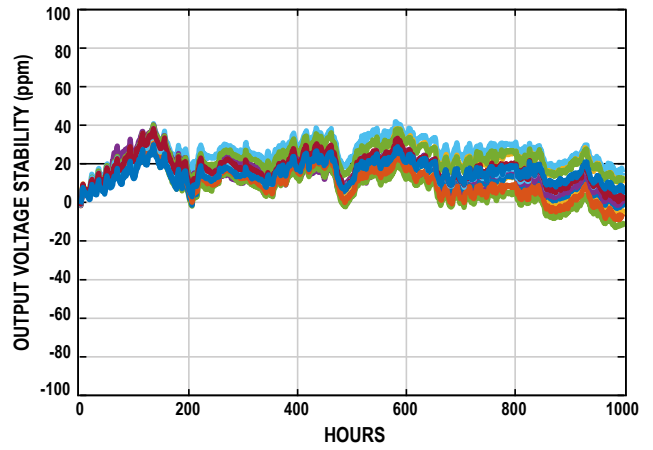

Figure 15. Long-Term Stability (MSOP-8 package)

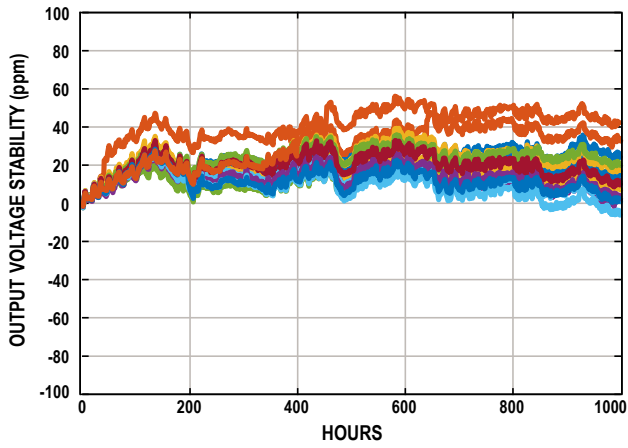

Figure 16. Long-Term Stability (SOIC-8 package)

Terminology

Temperature Coefficient

The change of output voltage over the operating temperature range is normalized by the output voltage at 25 °C, and expressed in ppm/°C as

$$dV_{OUT}/dT = \frac{V_{OUT(max)} - V_{OUT(min)}}{V_{OUT(25)} \times (T2 - T1)} \times 10^6$$

Where:

$V_{OUT(25)}$: Output voltage at 25 °C.

$V_{OUT(min)}$: The lowest output voltage over temperature T1 to T2 range.

$V_{OUT(max)}$: The highest output voltage over temperature range T1 to T2.

For TOKMAS voltage references, temperature T1 is -40 °C, and T2 is +125 °C.

Long-term Stability

This is the measurement of the change in output voltage of the measured device at 25 °C after 1000 hours (approximately 42 days) of operation at a constant ambient temperature. Generally measured in ppm. Long-term stability is not only affected by variations in the device itself, but also by soldering and board materials. Long-term stability generally exhibits a logarithmic characteristic, therefore the change in the second 1000 hours will be much smaller than the change in the first 1000 hours.

$$LTD = \frac{V_{OUT(t0)} - V_{OUT(t1)}}{V_{OUT(t0)}} \times 10^6$$

where:

$V_{OUT(t0)}$: Output voltage at 25 °C at Time 0.

$V_{OUT(t1)}$: Output voltage at 25 °C at Time 1 after 1000 hours of operation under constant ambient temperature.

Thermal Hysteresis

The change of output voltage after the device is cycled through temperatures from +25 °C to -40 °C to +125 °C and back to +25 °C. This is a typical value from a sample of parts put through such a cycle. It is normally in ppm using the following equation:

$$TH = \frac{V_{OUT(25)} - V_{OUT(TC)}}{V_{OUT(25)}} \times 10^6$$

where:

$V_{OUT(25)}$: Output voltage at 25 °C.

$V_{OUT(TC)}$: Output voltage at 25 °C after the temperature cycle.

Line Regulation

The change in output voltage due to a specified change in input voltage. It includes the effects of self-heating. Line regulation is expressed in either percent per volt, parts per million per volt, or microvolts per volt change in input voltage, such as ppm/V.

Load Regulation

The change in output voltage due to a specified change in load current. It includes the effects of self-heating. Load regulation is expressed in either microvolts per milliampere or parts per million per milliampere, such as ppm/mA.

Theory of Operation

ADRXXX is a family of low power, low noise and precision voltage reference, which were developed in 40 V BCD process. Figure 17 shows its simplified schematic. The bandgap circuit is the key building block, which was carefully optimized and trimmed in order to deliver the outstanding low temperature co-efficient. The output amplifier provides sufficient driving capability. EN enables or disables the part for normal operation.

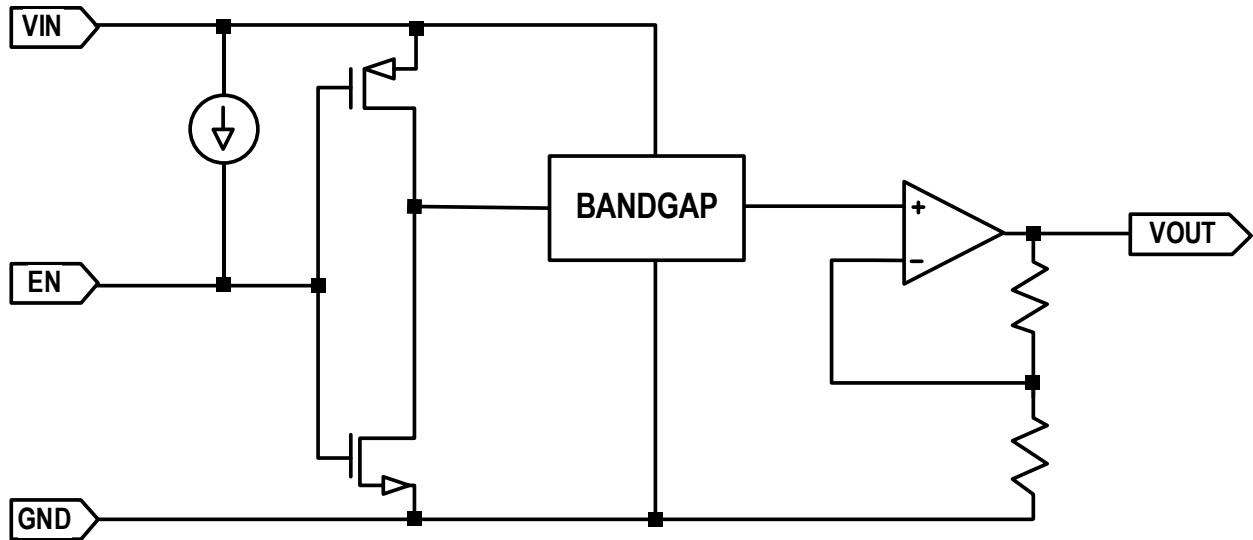

Figure 17. Simplified schematic of ADRXXX

Applications

Typical Configuration

Typical configuration of modern series voltage reference is straight forward. ADRXXX normally requires a load cap of $0.1\ \mu\text{F}$ ~ $10\ \mu\text{F}$ between V_{OUT} and GND. An input bypass cap of $1\ \mu\text{F}$ is desirable for better power supply rejection as show in Figure 18.

Note the load capacitor ranges from $0.1\ \mu\text{F}$ to $10\ \mu\text{F}$. Excessive load cap might lead to output settling problem or sometimes oscillation, as well as slower start up. The equivalent series resistance (ESR) of cap is recommended to be less than $1.5\ \text{ohm}$ in order to ensure circuit stability. Optimal capacitance value depends on the load condition of the part. For example, if ADRxxx directly drives SAR ADC, such as AD7690, $1\ \mu\text{F}$ or $2.2\ \mu\text{F}$ offers good noise and settling performance.

It is recommended to use surface-mounted ceramic capacitors (such as X5R, X7R). If an electrolytic capacitor is used at the output, a $0.1\ \mu\text{F}$ ceramic capacitor should be placed in parallel to reduce the overall ESR at the output. In addition, the capacitors' operating temperature range and voltage rating shall be at least as wide as the system requirement.

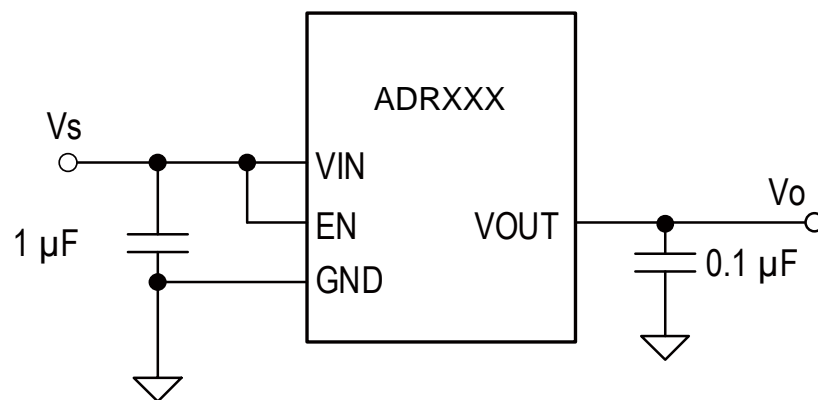

Figure 18. ADRXXX Typical Configuration

Power on and Shutdown mode

Figure 10 shows the power-on process of ADRXXX. The value of the load capacitor affects the turn-on time. In general, the larger the load cap, the longer the settling time. Settling to higher accuracy sees exponentially longer turn-on time.

For power consumption sensitive applications, ADRXXX offers useful shut down feature. The part burns just $10\ \mu\text{A}$ in shutdown mode, the shutdown procedure can be found in Figure 11 and Figure 12. Shutdown mode is controlled by pin 3 (EN). The voltage threshold of this pin is around $1.2\ \text{V}$ and compatible with CMOS/TTL logic.

There is an internal weak pull-up current $0.22\ \mu\text{A}$ on chip. If the pin is left floating, its voltage rises close to V_{IN} and the part is enabled. Due to the weak pull-up nature, it is recommended that the EN pin be pulled high externally for normal operation to prevent accidental shut down.

Supply Voltage

ADRXXX has a wide supply voltage range. The lowest supply voltage for ADR4520 is $2.8\ \text{V}$, while in other versions it can be as low as output voltage plus $300\ \text{mV}$. Supply voltage of $10\ \text{V}$ higher is widely used in many applications, such as industrial control systems. ADRXXX's highest supply voltage of $40\ \text{V}$ might simplify system power supply design.

It is recommended to power ADRXXX by linear power supplies, such as LDO, in order to ensure high frequency performances.

Layout Guidelines

- Place the power-supply bypass capacitor as closely as possible to the supply and ground pins. The recommended value of this bypass capacitor is from 1 μF to 10 μF . If necessary, additional decoupling capacitance can be added to compensate for noisy or high-impedance power supplies.
- The output must be decoupled with a bigger than 0.1 μF capacitor. For better noise performance, the recommended ESR on the output capacitor is from 1 Ω to 1.5 Ω . For even lower noise, a larger capacitor in parallel or an RC filter can be added.
- Use large area ground plane if possible. Keep fast-changing or high-frequency interference signals far from ADRXXX.

Layout Example

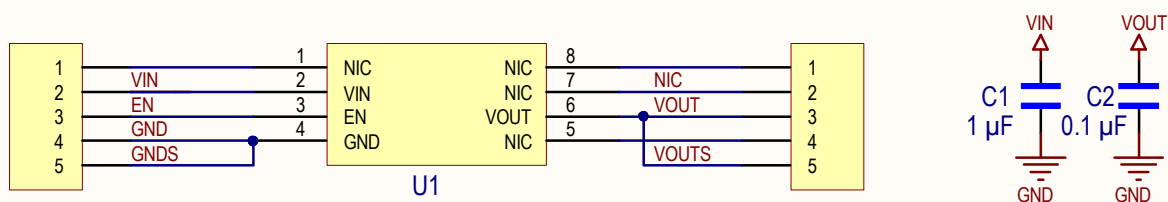

Figure 20. ADRXXX Evaluation Board Schematic

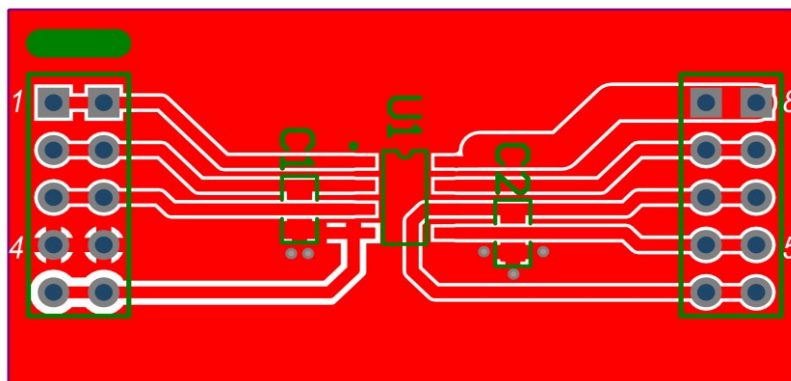

Figure 21. ADRXXX Evaluation Board Layout (TopLayer)



Figure 22. ADRXXX Evaluation Board Layout (Bottom Layer)

Outline Dimensions

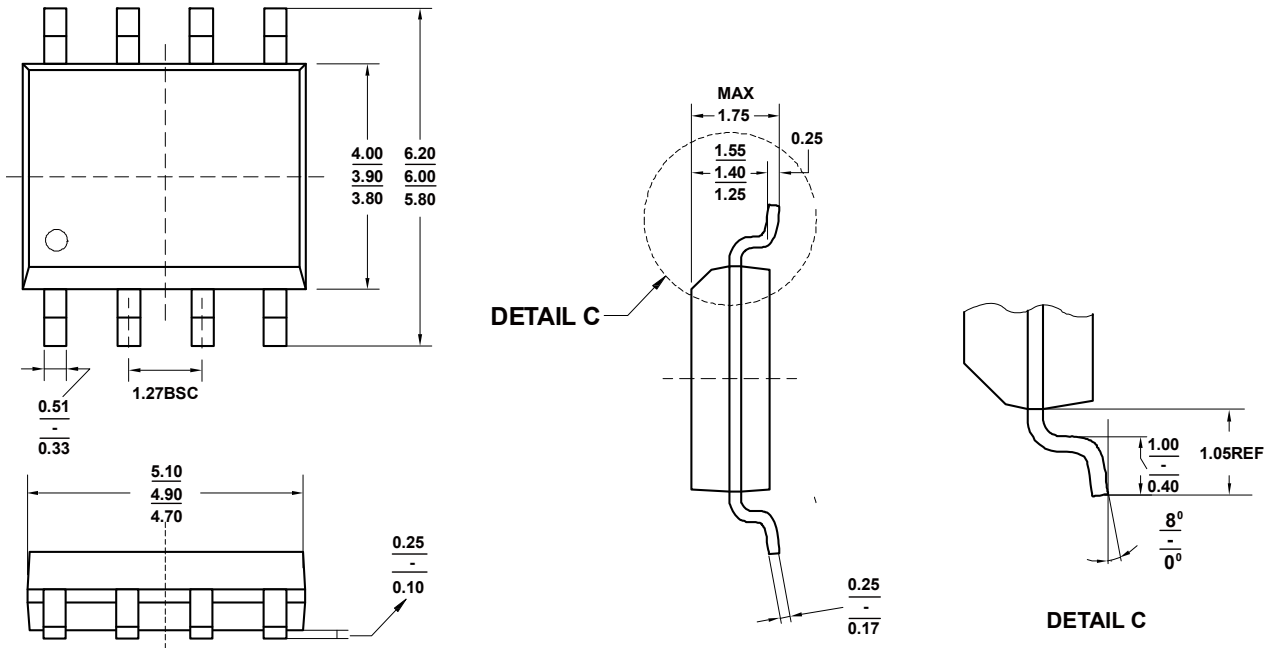

Figure 23. 8-Lead SOIC Package Dimensions shown in millimeters

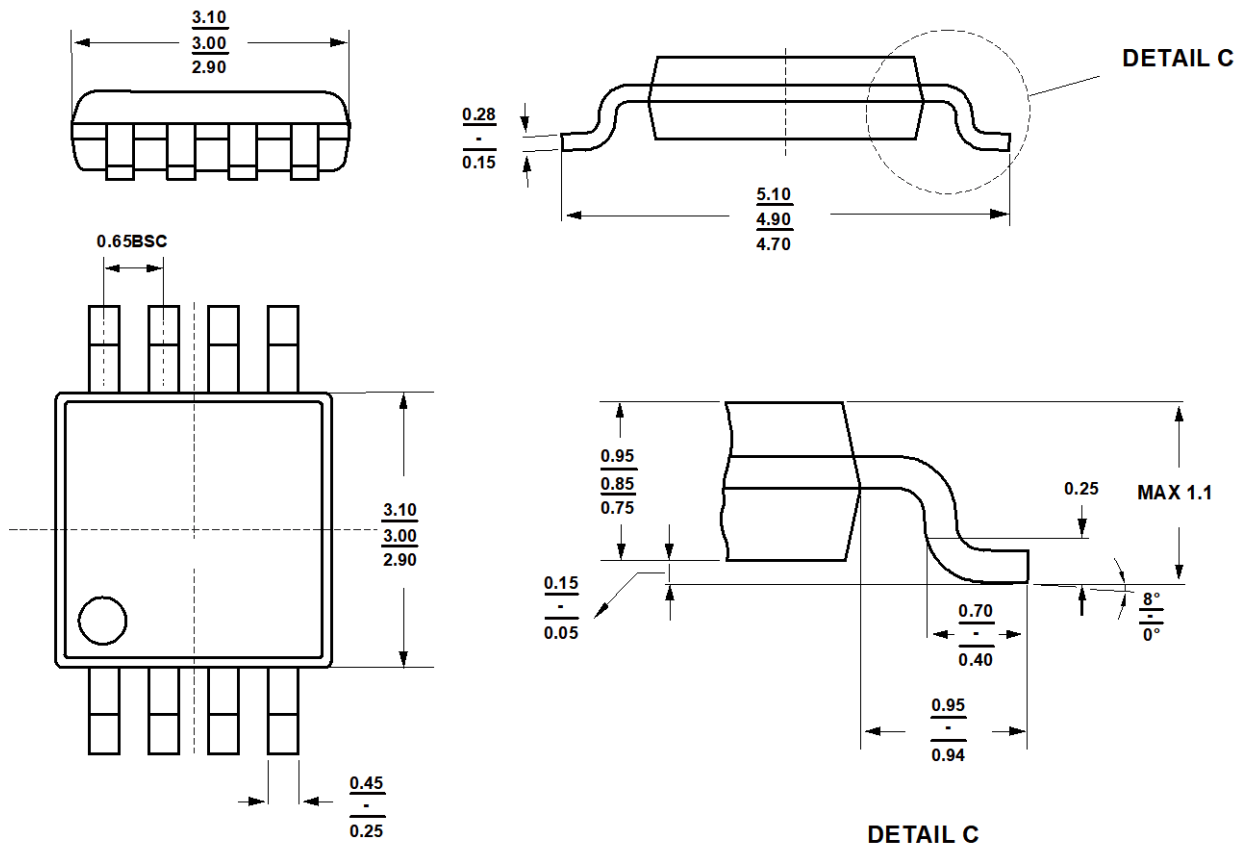

Figure 24. 8-Lead MSOP Package Dimensions shown in millimeters

Ordering Guide

Model	Orderable Device	Temperature Range (°C)	Output Voltage (V)	Max TempCo (ppm/°C)	Package	External Package
ADR4520	ZADR4520BRZ	-40 to +125	2.048	5	SOIC-8	Tube
	ADR4520BRZ-R7				SOIC-8	13" Reel
	ADR4520BR				MSOP-8	Tube
	ADR4520BS				MSOP-8	13" Reel
	ADR4520ARZ			8	SOIC-8	Tube
	ADR4520ARZ-R7				SOIC-8	13" Reel
	ADR4520AR				MSOP-8	Tube
	ADR4520AS				MSOP-8	13" Reel
	ADR4520CRZ			3	SOIC-8	Tube
	ADR4520CRZ-R7				SOIC-8	13" Reel
	ADR4520CR	MSOP-8			Tube	
	ADR4520CS	MSOP-8			13" Reel	
	ADR4520DRZ	-40 to +85		5	SOIC-8	Tube
	ADR4520DRZ-R7				SOIC-8	13" Reel
	ADR4520DR				MSOP-8	Tube
	ADR4520DS				MSOP-8	13" Reel
	ADR4520ERZ			8	SOIC-8	Tube
	ADR4520DRZ-R7				SOIC-8	13" Reel
	ADR4520ER				MSOP-8	Tube
	ADR4520ES				MSOP-8	13" Reel
ADR4525	ADR4525ARZP	-40 to +125	2.5	5	SOIC-8	Tube
	ADR4525ARZ				SOIC-8	13" Reel
	ADR4525ARZB				MSOP-8	Tube
	ADR4525ARZC				MSOP-8	13" Reel
	ADR4525ARZE			8	SOIC-8	Tube
	ADR4525ARZ-R7				SOIC-8	13" Reel
	ADR4525AR				MSOP-8	Tube
	ADR4525AS				MSOP-8	13" Reel
	ADR4525BRP			3	SOIC-8	Tube
	ADR4525BRZ				SOIC-8	13" Reel
	ADR4525BR	MSOP-8			Tube	
	ADR4525BS	MSOP-8			13" Reel	
	ADR4525ARC	-40 to +85		5	SOIC-8	Tube
	ADR4525ARC-R7				SOIC-8	13" Reel
	ADR4525CR				MSOP-8	Tube
	ADR4525CS				MSOP-8	13" Reel
	ADR4525ERZ			8	SOIC-8	Tube
	ADR4525ERZ-R7				SOIC-8	13" Reel
	ADR4525ER				MSOP-8	Tube
	ADR4525ES				MSOP-8	13" Reel

Model	Orderable Device	Temperature Range (°C)	Output Voltage (V)	Max TempCo (ppm/°C)	Package	External Package
ADR443	ADR443BRZ	-40 to +125	3	5	SOIC-8	Tube
	ADR443BRZ-R7				SOIC-8	13" Reel
	ADR443BR				MSOP-8	Tube
	ADR443BS				MSOP-8	13" Reel
	ADR443ARZ			SOIC-8	Tube	
	ADR443ARZ-R7			SOIC-8	13" Reel	
	ADR443AR			MSOP-8	Tube	
	ADR443AS			MSOP-8	13" Reel	
	ADR443CRZ	3		SOIC-8	Tube	
	ADR443ARZ-R7			SOIC-8	13" Reel	
	ADR443CR			MSOP-8	Tube	
	ADR443CS			MSOP-8	13" Reel	
	ADR443DRZ	-40 to +85		5	SOIC-8	Tube
	ADR443DRZ-R7				SOIC-8	13" Reel
	ADR443DR				MSOP-8	Tube
	ADR443DS				MSOP-8	13" Reel
	ADR443ERZ	8		SOIC-8	Tube	
	ADR443ERZ-R7			SOIC-8	13" Reel	
ADR443ER	MSOP-8		Tube			
ADR443ES	MSOP-8		13" Reel			
ADR4533	ADR4533BRZ	-40 to +125	3.3	5	SOIC-8	Tube
	ADR4533BRZ-R7				SOIC-8	13" Reel
	ADR4533BR				MSOP-8	Tube
	ADR4533BS				MSOP-8	13" Reel
	ADR4533ARZ			8	SOIC-8	Tube
	ADR4533ARZ-R7				SOIC-8	13" Reel
	ADR4533AR				MSOP-8	Tube
	ADR4533AS				MSOP-8	13" Reel
	ADR4533CRZ	3		SOIC-8	Tube	
	ADR4533CRZ-R7			SOIC-8	13" Reel	
	ADR4533CR			MSOP-8	Tube	
	ADR4533CS			MSOP-8	13" Reel	
	ADR4533DRZ	-40 to +85		5	SOIC-8	Tube
	ADR4533DRZ-R7				SOIC-8	13" Reel
	ADR4533DR				MSOP-8	Tube
	ADR4533DS				MSOP-8	13" Reel
	ADR4533ERZ	8		SOIC-8	Tube	
	ADR4533ERZ-R7			SOIC-8	13" Reel	
ADR4533ER	MSOP-8		Tube			
ADR4533ES	MSOP-8		13" Reel			



Model	Orderable Device	Temperature Range (°C)	Output Voltage (V)	Max TempCo (ppm/°C)	Package	External Package
ADR4540	ADR4540BRZ	-40 to +125	4.096	5	SOIC-8	Tube
	ADR4540BRZ-R7				SOIC-8	13" Reel
	ADR4540BR				MSOP-8	Tube
	ADR4540BS				MSOP-8	13" Reel
	ARZ4540ARZ			SOIC-8	Tube	
	ADR4540ARZ-R7			SOIC-8	13" Reel	
	ADR4540AR			MSOP-8	Tube	
	ADR4540AS			MSOP-8	13" Reel	
	ADR4540CRZ	SOIC-8	Tube			
	ADR4540CRZ-R7	SOIC-8	13" Reel			
	ADR4540CR	MSOP-8	Tube			
	ADR4540CS	MSOP-8	13" Reel			
	ADR4540DRZ	-40 to +85	4.096	5	SOIC-8	Tube
	ADR4540DRZ-R7				SOIC-8	13" Reel
	ADR4540DR				MSOP-8	Tube
	ADR4540DS				MSOP-8	13" Reel
ADR4540ERZ	SOIC-8			Tube		
ADR4540ERZ-R7	SOIC-8			13" Reel		
ADR4540ER	MSOP-8			Tube		
ADR4540ES	MSOP-8			13" Reel		
ADR4550	ADR4550BRZ	-40 to +125	5.0	5	SOIC-8	Tube
	ADR4550BRZ-R7				SOIC-8	13" Reel
	ADR4550BR				MSOP-8	Tube
	ADR4550BS				MSOP-8	13" Reel
	ADR4550ARZ			SOIC-8	Tube	
	ADR4550ARZ-R7			SOIC-8	13" Reel	
	ADR4550AR			MSOP-8	Tube	
	ADR4550AS			MSOP-8	13" Reel	
	ADR4550CRZ	SOIC-8	Tube			
	ADR4550CRZ-R7	SOIC-8	13" Reel			
	ADR4550CR	MSOP-8	Tube			
	ADR4550CS	MSOP-8	13" Reel			
	ADR4550DRZ	-40 to +85	5.0	5	SOIC-8	Tube
	ADR4550DRZ-R7				SOIC-8	13" Reel
	ADR4550DR				MSOP-8	Tube
	ADR4550DS				MSOP-8	13" Reel
ADR4550ERZ	SOIC-8			Tube		
ADR4550ERZ-R7	SOIC-8			13" Reel		
ADR4550ER	MSOP-8			Tube		
ADR4550ES	MSOP-8			13" Reel		