

HDC HVE 10+2 MT CTH**Weidmüller Interface GmbH & Co. KG**

Klingenbergstraße 26

D-32758 Detmold

Germany

www.weidmueller.com



The HVE-series high-voltage inserts are equipped with two lagging contacts.

The wire connection level is designed as a crimp contact. Thus practically no servicing is required. In addition, a secure and permanent connection is established which is resistant to vibrations.

Number of poles: **12**

Rated current: **23 A**

Rated voltage: **830 V**

Nominal voltage acc. to UL/CSA: **600 V AC/DC**

Tension clamp connection

General ordering data

Version	HDC insert, Male, 830 V, 20 A, Number of poles: 12, Tension-clamp connection, Size: 8
Order No.	1967210000
Type	HDC HVE 10+2 MT CTH
GTIN (EAN)	4032248661213
Qty.	1 pc(s).

Creation date September 17, 2022 8:25:55 PM CEST

Catalogue status 09.09.2022 / We reserve the right to make technical changes.

HDC HVE 10+2 MT CTH

Weidmüller Interface GmbH & Co. KG

Klingenbergstraße 26

D-32758 Detmold

Germany

www.weidmueller.com

Technical data

Dimensions and weights

Depth	111 mm	Depth (inches)	4.37 inch
Height	33.5 mm	Height (inches)	1.319 inch
Width	34 mm	Width (inches)	1.339 inch
Net weight	82 g		

Temperatures

Limit temperature -40 °C ... 125 °C

Environmental Product Compliance

REACH SVHC Lead 7439-92-1, Potassium perfluorobutane sulfonate 29420-49-3
 SCIP b67daa31-7dca-434d-8290-da7fb52f83a2

Chemical resistance	Substance	Chemical resistance
	Acetone	Resistant
	Ammonia, watery	Conditionally resistant
	Petrol	Resistant
	Benzene	Resistant
	Diesel oil	Conditionally resistant
	Acetic acid, concentrated	Resistant
	Potassium hydroxide	Conditionally resistant
	Methanol	Conditionally resistant
	Motor oil	Conditionally resistant
	Lye, diluted	Resistant
	Hydrochlorofluorocarbons	Conditionally resistant
	Outdoor use	Conditionally resistant

Dimensions

Height of plug	33.5 mm	Total length base	111 mm
Width	34 mm		

HDC HVE 10+2 MT CTH

Weidmüller Interface GmbH & Co. KG

Klingenbergstraße 26

D-32758 Detmold

Germany

www.weidmueller.com

Technical data

General data

BG	8	Conductor cross-section	2.5 mm ²
Insulating material	PC glass-fibre reinforced (UL-listed and railway-certified)	Insulating material group	IIIa
Insulation strength	10 ¹⁰ Ω	Material	Copper alloy
Number of poles	12	Number of power contacts	10
Number of signal contacts	2	Plugging cycles, silver	≥ 500
Pollution severity	3	Rated current (DIN EN 61984)	20 A
Rated impulse voltage (DIN EN 61984)	8 kV	Rated voltage (DIN EN 61984)	830 V
Rated voltage according to UL/CSA	600 V AC/DC	Series	HVE
Size	8	Surface finish	Silver passivated
Type	Male	UL 94 flammability rating	V-0
Volume resistance	≤2 mΩ		

Connection data PE

Blade size, slotted (PE connection)	SD 0.8 x 4.0	Connection type PE	Screw connection
Fixing screw	M 4	Rated cross-section	4 mm ²
Stripping length PE connection	10 mm	Tightening torque, max. PE connection	1.5 Nm
Tightening torque, min. PE connection	1.2 Nm	Wire cross section, AWG (PE), max.	AWG 12
Wire cross section, AWG (PE), min.	AWG 20		

Version

BG	8	Blade size, slotted (screw connection)	SD 0.5 x 3.0
Conductor cross-section, max.	2.5 mm ²	Conductor cross-section, min.	0.25 mm ²
Material	Copper alloy	Size	8
Stripping length, rated connection	8 mm	Surface finish	Silver passivated
Type of connection	Tension-clamp connection	Volume resistance	≤2 mΩ
Wire connection cross section AWG, max.	AWG 14	Wire connection cross section AWG, min.	AWG 24
Wire connection cross section, finely stranded, max.	4 mm ²	Wire connection cross section, finely stranded, min.	0.5 mm ²
Wire connection cross-section, finely stranded with wire-end ferrules DIN 46228/4, max.	4 mm ²	Wire connection cross-section, finely stranded with wire-end ferrules DIN 46228/4, min.	0.5 mm ²
Wire cross-section, solid, max.	4 mm ²	Wire cross-section, solid, min.	0.5 mm ²

Classifications

ETIM 6.0	EC000438	ETIM 7.0	EC000438
ETIM 8.0	EC000438	ECLASS 9.0	27-44-02-05
ECLASS 9.1	27-44-02-05	ECLASS 10.0	27-44-02-05
ECLASS 11.0	27-44-02-05	ECLASS 12.0	27-44-02-05

Approvals

Approvals



ROHS

Conform

Creation date September 17, 2022 8:25:55 PM CEST

Catalogue status 09.09.2022 / We reserve the right to make technical changes.

3

HDC HVE 10+2 MT CTH

Weidmüller Interface GmbH & Co. KG
Klingenbergstraße 26
D-32758 Detmold
Germany

www.weidmueller.com

Technical data**Downloads**

Engineering Data	CAD data – STEP
Engineering Data	EPLAN, WSCAD
Catalogues	Catalogues in PDF-format
Brochures	FL FIELDWIRING EN FL FIELDWIRING EN

Data sheet

HDC HVE 10+2 MT CTH

Weidmüller Interface GmbH & Co. KG
Klingenbergstraße 26
D-32758 Detmold
Germany

www.weidmueller.com

Drawings

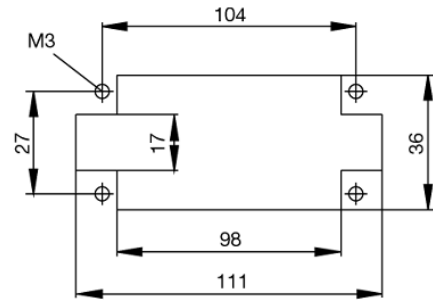
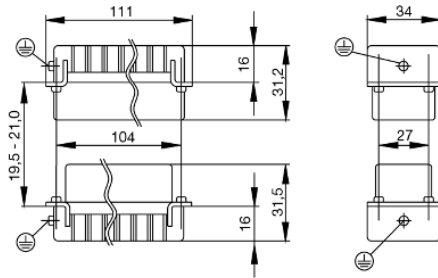

Tightening torques and screwing tools

Screw size	Connector type	Dia. tightening torque in Nm	Recommended blade inserts and AF size for hexagon socket	
M 2.5	Signal contacts			
	S 6/6	0.5 - 0.55	SD 0.6 x 3.5 mm or PZ0	
	S 6/12	0.5 - 0.55	SD 0.6 x 3.5 mm or PZ0	
M 2.9 x 0.5	Fastening screws			
	HQ 4/2	0.8 (plastic) / 1.1 (metal)	SD 0.6 x 3.5 mm or PH0	
	HQ 8	0.8 (plastic) / 1.1 (metal)	SD 0.6 x 3.5 mm or PH0	
	HQ 17	0.8 (plastic) / 1.1 (metal)	SD 0.6 x 3.5 mm or PH0	
M 3	Contact screws			
	HA 3	0.5 - 0.55	SD 0.5 x 3.0 mm	
	HA 4	0.5 - 0.55	SD 0.5 x 3.0 mm	
	HA 10 bis HA 48	0.5 - 0.55	SD 0.6 x 3.5 mm or PH0	
	HE	0.5 - 0.55	SD 0.6 x 3.5 mm or PZ0	
	HVE	0.5 - 0.55	SD 0.6 x 3.5 mm or PZ0	
	Signal contacts:			
	S 4/2	0.5 - 0.55	SD 0.6 x 3.5 mm or PZ0	
	S 4/8	0.5 - 0.55	SD 0.6 x 3.5 mm or PZ0	
	PE connection via female contact			
	S 4	0.5 - 0.8	SD 0.6 x 3.5 mm	
	ConCept modular frame, metal	0.5 - 0.55	SD 0.6 x 3.5 mm	
	PE terminal			
	HQ 5	0.5 - 0.55	SD 0.6 x 3.5 or 0.8 x 4 mm	
	HQ 7	0.5 - 0.55	SD 0.6 x 3.5 or 0.8 x 4 mm	
	Fastening screws	0.5 - 0.55	SD 0.6 x 3.5 mm or PZ0	
	Guide pin	0.5 - 0.55	SD 0.6 x 3.5 mm or PZ0	
	Guide bush	0.5 - 0.55	SD 0.6 x 3.5 mm or PZ0	
	Coding pins	0.5 - 0.55	SD 0.6 x 3.5 mm or PZ0	
	M 4	Contact screws		
		HSB	1.2 - 1.5	SD 0.6 x 3.5 or 0.8 x 4 mm or PZ1
PE connection via male contact				
S 4		0.5 - 0.8	SD 0.6 x 3.5 mm	
ConCept modular frame, metal		1.2 - 1.5	SD 0.6 x 3.5 mm	
PE terminal				
HA		1.2 - 1.5	SD 0.6 x 3.5 or 0.8 x 4 mm or PH1	
HE		1.2 - 1.5	SD 0.6 x 3.5 or 0.8 x 4 mm or PH1	
HEE		1.2 - 1.5	SD 0.6 x 3.5 or 0.8 x 4 mm or PH1	
HVE		1.2 - 1.5	SD 0.6 x 3.5 or 0.8 x 4 mm or PH1	
HD		1.2 - 1.5	SD 0.6 x 3.5 or 0.8 x 4 mm or PZ1	
HDD		1.2 - 1.5	SD 0.6 x 3.5 or 0.8 x 4 mm or PZ1	
S 6/6 (for signal contacts)		1.2 - 1.5	0.8 x 4 mm or PZ1	
ConCept modular frame, plastic		1.2 - 1.5	0.8 x 4 mm or PZ1	
M 5		PE terminal		
	HSB	2 - 2.5	SD 1 x 5.5 mm or PZ2	
	S 4/0 (Screw connection)	2 - 2.5	SD 1.2 x 6.5 mm or PH2	
	S 4/0 (Axial screw connection)	2 - 2.5	SD 0.8 x 4 mm or PZ 2	
	S 4/2	2 - 2.5	SD 1.2 x 6.5 mm or PH2	
	S 4/8	2 - 2.5	SD 1.2 x 6.5 mm or PH2	
	S 6/12	2 - 2.5	SD 0.8 x 4 mm or PZ 2	
	S 6/36	2 - 2.5	SD 1.2 x 6.5 mm or PH2	
	S 8/24	2 - 2.5	SD 1.2 x 6.5 mm or PH2	
	S 12/2	2 - 2.5	SD 1.2 x 6.5 mm or PH2	
	M 6	Power contacts		
S 4/0 (Screw connection)		1.2 (1.5 mm ²) / 2 (2.5 mm ²) / 3 (4-16 mm ²)	SD 0.8 x 4 mm	
S 4/2		1.2 (1.5 mm ²) / 2 (2.5 mm ²) / 3 (4-16 mm ²)	SD 0.8 x 4 mm	
S 4/8		1.2 (1.5 mm ²) / 2 (2.5 mm ²) / 3 (4-16 mm ²)	SD 0.8 x 4 mm	
M 7 x 0.75	Power contacts			
	S 4	1.1 - 1.7	SW 2	
	S 6/6 (+ PE)	6 - 8	SW 4	
M 8 x 0.75	Power contacts			
	S 6/12	1.1 - 1.7	SW 2	
	S 8/0 (+ PE)	6 (10-16 mm ²) - 7 (25 mm ²)	SW 4	
M10 x 1	Power contacts			
	S 4/0 (Axial connection)	2 - 3	SW 3	

Increasing the tightening torque does not improve the contact resistance. The stated torque settings offer optimal mechanical, thermal and electrical conditions. Exceeding the recommended values may even damage the conductor and terminal.