

Safety Door Switch with Key

SG-B2 SERIES





Solve issues related to machine safety and other safety measures with a safety door switch with key!

No forgotten keys, No locked-in workers, No inadvertent machinery operation!

The safety door switch with key **SG-B2** series locks and unlocks doors with keys. When an operator takes a key into a hazardous area, the safety door switch will not lock, and the equipment will stop, ensuring operator safety by preventing personnel from being closed inside the hazardous area and preventing equipment from starting to operate.

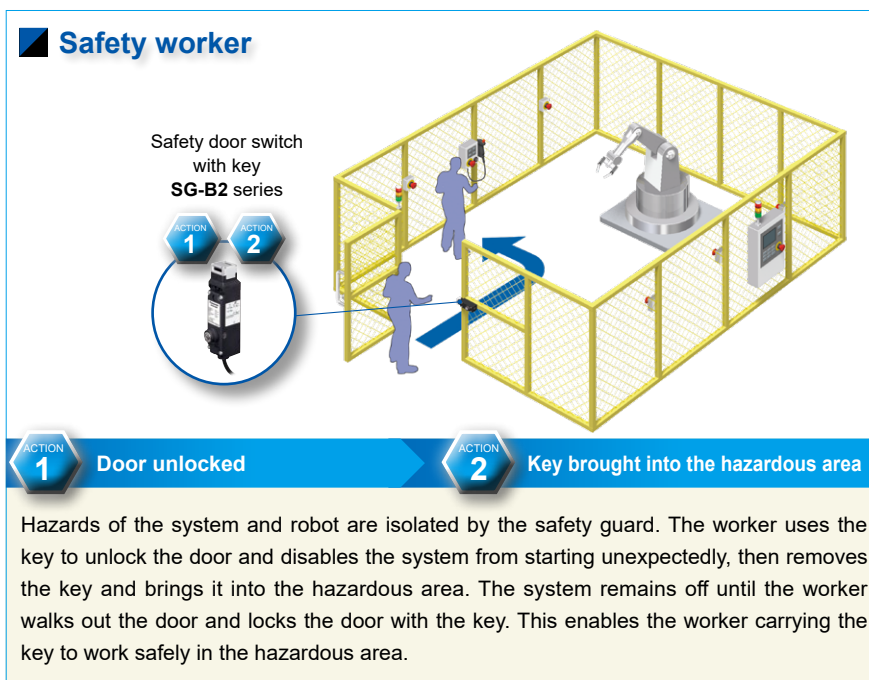

Energy-saving design, no power supply required

Since doors are locked and unlocked with a key, there is no need to supply power to the safety door switch.

Head removal detection function

Head removal detection function is employed in the **SG-B2**. With this innovative function, the monitor circuit (41-42) turns off when the head is removed from the switch, such as when removing the head to change the head direction. With the head installed on the switch, monitor circuits 41-42 and 51-52 operate in synchronization while the key locks / unlocks the actuator. When the head is removed, 41-42 turns off and 51-52 turns on. This disagreement is detected by the head removal detection function.



Monitor circuit	Actuator unlocked	Actuator locked	When the head removed
LOCK UNLOCK Monitor circuit (NC) Pink ⊖ 41 ——— 42 Pink / White	OFF	ON	OFF
Monitor circuit (NC) Brown ⊖ 51 ——— 52 Brown / White	OFF	ON	ON

Disagreement

Note: Head removal detection function is not direct opening.

High-security pin tumbler key types are used



All models come with cables pre-installed.

Double-insulated design eliminates the need for grounding wires.

Choose an actuator based on the door shape and application.

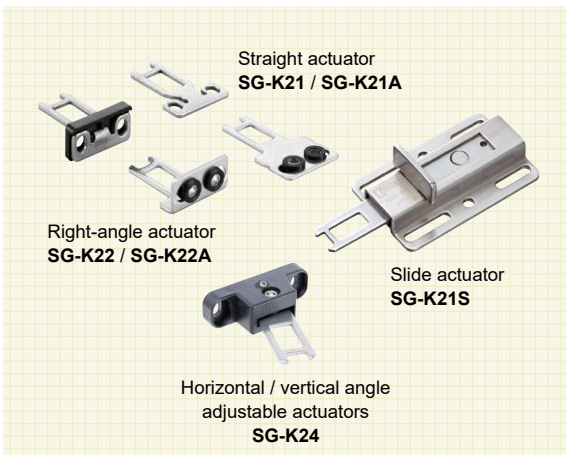

Available with rear unlocking button



Models with a rear unlocking button allow the door to be unlocked from the inside in the event a worker is left in the hazardous area.

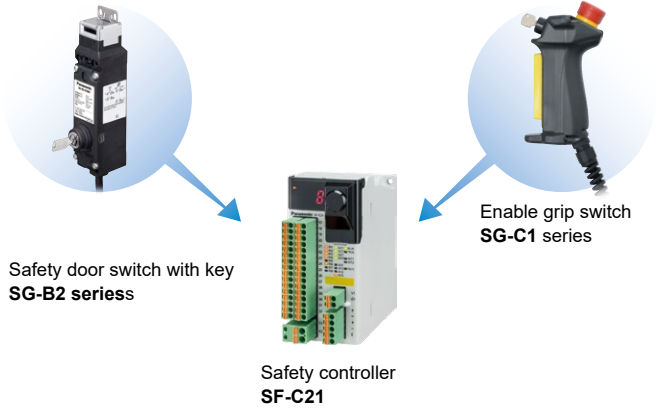

Equipment combination examples related to machine safety



ORDER GUIDE

Safety door switch with key

Actuators are not included with door switches and must be purchased separately.

Rear unlocking button	Contact arrangement (Note)	Cable length	Key removal position	Model No.
Without	 Monitor circuit : Blue ⊕ 11 — 12 Blue / White Monitor circuit : Orange ⊕ 23 — 24 Orange / White  LOCK UNLOCK Pink ⊕ 41 — 42 Pink / White Brown ⊕ 53 — 54 Brown / White	5 m 16.404 ft	A (removable in all positions)	SG-B2-K2AC-5
			B (removable in UNLOCK position)	SG-B2-K2BC-5
			C (removable in LOCK position)	SG-B2-K2CC-5
With	Monitor circuit : Blue ⊕ 11 — 12 Blue / White Monitor circuit : Orange ⊕ 21 — 22 Orange / White Pink ⊕ 41 — 42 Pink / White Brown ⊕ 51 — 52 Brown / White	5 m 16.404 ft	A (removable in all positions)	SG-B2-K2AD-5
			B (removable in UNLOCK position)	SG-B2-K2BD-5
			C (removable in LOCK position)	SG-B2-K2CD-5
With	Monitor circuit : Blue ⊕ 11 — 12 Blue / White Monitor circuit : Orange ⊕ 21 — 22 Orange / White Pink ⊕ 41 — 42 Pink / White Brown ⊕ 51 — 52 Brown / White	5 m 16.404 ft	A (removable in all positions)	SG-B2-K2AD-L5
			B (removable in UNLOCK position)	SG-B2-K2BD-L5
			C (removable in LOCK position)	SG-B2-K2CD-L5

Note: The contact configuration shows the status when the actuator is inserted and the switch is locked. Key LOCK and UNLOCK positions are as shown on the right.

Switches incorporate two detents so that they stop in each position.



ORDER GUIDE

Actuators

Actuators are not included with door switches and must be purchased separately.

Type	Description	Model No.
Straight actuator	The actuator tensile strength when using this product is 1,400 N.	SG-K21
Straight actuator with rubber bushings		SG-K21A
Slide actuator		SG-K21S
Right-angle actuator		SG-K22
Right-angle actuator with rubber bushings		SG-K22A
Horizontal / vertical angle adjustable actuators	The actuator tensile strength when using this product is 500 N.	SG-K24

Note: When using a safety door switch with key on a hinged door, see page 8 for more information about the minimum door radius with which the switch can be used.



OPTIONS

Type	Model No.
Padlock hasp (Note 1)	SG-PH2
Mounting plate (for mounting on an aluminum frame)	MS-SG-21
Rear unlocking button kit for a frame (Note 2)	MS-SG-22
	MS-SG-23

Notes: 1) The shackle diameter for compliant padlocks ranges from $\varnothing 5.5$ to $\varnothing 7.5$ mm $\varnothing 0.217$ to $\varnothing 0.295$ in.

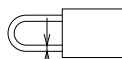

Shackle diameter: $\varnothing 5.5$ to $\varnothing 7.5$ mm $\varnothing 0.217$ to $\varnothing 0.295$ in

2) For more information about selecting a back manual unlock button kit for a frame, see the following table:

Model No.	Mounting part* thickness (X) (mm in)
	Rear unlocking button type When installing an SG-B2-K2□D-L5 with a rear unlocking button directly
MS-SG-22	$33 < X \leq 43$ $1.299 < X \leq 1.693$
MS-SG-23	$23 < X \leq 33$ $0.906 < X \leq 1.299$

* The mounting part is a frame or a panel that the product is mounted on.

Padlock hasp

- **SG-PH2**



Mounting plate (for mounting on an aluminum frame)

- **MS-SG-21**



Rear unlocking button kit for a frame

- **MS-SG-22**
- **MS-SG-23**



CONTACT CONFIGURATION / OPERATING PATTERNS

■ : Closed □ : Open

	Status 1	Status 2	Status 3	Rear manual unlock	
Safety switch status	• Door closed • Machine ready to operate	• Door closed • Machine cannot be operated	• Door open • Machine cannot be operated	• Door closed • Machine cannot be operated	
Door status				 • Press rear unlocking button. (Note 1)	
Circuit diagram (Example: SG-B2-K2□D-L5)					
Door	• Closed (locked)	• Closed (unlocked)	• Open	• Closed (unlocked)	
Model No. and contact configuration	SG-B2-K2□C-5 	Monitor circuit (door closed) 11-12			
		Monitor circuit (door open) 23-24			
		Monitor circuit (locked) 41-42			
		Monitor circuit (unlocked) 53-54			
	SG-B2-K2□D-5 	Monitor circuit (door closed) 11-12			
		Monitor circuit (door closed) 21-22			
		Monitor circuit (locked) 41-42			
		Monitor circuit (locked) 51-52			
	SG-B2-K2□D-L5 	Monitor circuit (door closed) 11-12			
		Monitor circuit (door closed) 21-22			
		Monitor circuit (locked) 41-42			
		Monitor circuit (locked) 51-52			

- Notes: 1) When the operator is confined in a hazardous area, the actuator can be unlocked manually by pressing the rear unlocking button, which should be accessed easily by the operator.
 2) The above contact configuration shows the status when the actuator is inserted and the switch is locked.
 3) Monitor circuit: Sends monitoring signals of protective door open / closed status or protective door lock / unlock status.

• **Operation characteristics** ■ : Contact ON (closed) □ : Contact OFF (opened) (reference)

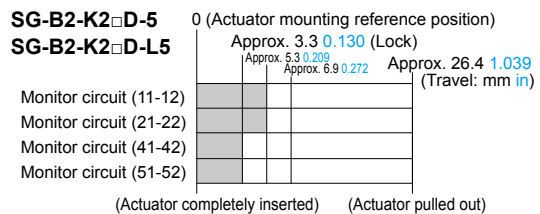
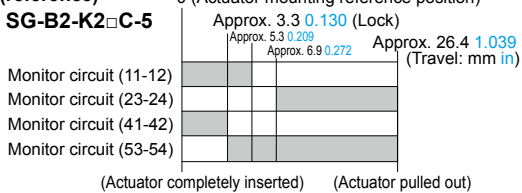

- The characteristics show the contact status when the actuator enters an entry slot of a safety switch.
 • The characteristics shown in the chart above are of the **SG-K21** actuator. For the others actuator, add 1.3 mm 0.051 in.



When connecting the **SG-B2** series to a safety circuit, connect the door monitor circuits (11-12) ⊕ and the lock monitor circuits (41-42, 51-52) in series. (GS-ET-19)

SPECIFICATIONS

Designation	Safety door switch with key					
Item Series	SG-B2 series					
Applicable standards	EN 60947-5-1, GS-ET-19					
Standards for use	IEC 60204-1 / EN 60204-1, ISO 14119, EN ISO 14119, IEC 60947-5-1, UL 508, CSA C22.2 No. 14					
Applicable regulations	CE Marking [Machinery Directive (2006/42/EC), RoHS Directive], UKCA Marking [Supply of Machinery (Safety) Regulations (2008 No.1597), RoHS Regulations]					
Operating condition	Ambient temperature	-25 to +70 °C -13 to +158 °F (No dew condensation or icing allowed) Storage: -40 to +80 °C -40 to +176 °F				
	Ambient humidity	45 to 85 % RH				
	Pollution degree	3 (Inside 2)				
	Altitude	2,000 m 6,561.68 ft max.				
Impulse withstand voltage (Uimp)	2.5 kV					
Rated insulation voltage (Ui)	250 V (Note 1)					
	2.5 A					
Thermal current (Ith)	Ambient temperature: -25 to +60 °C -13 to +140 °F : 2.5 A max. +60 to +65 °C +140 to +149 °F : 1.5 A max. +65 to +70 °C +149 to +158 °F : 1.0 A max.					
	Rated operational voltage (Ue) / Rated operational current (Ie)	AC	le	30 V	125 V	250 V
			Resistive load (AC-12)	-	2.5 A	1.5 A
		DC	Resistive load (DC-12)	2.5 A	1.1 A	0.55 A
Inductive load (DC-13)			2.3 A	0.55 A	0.27 A	
Operating frequency	900 operations/hour					
Actuator operating speed	0.05 to 1.0 m/sec.					
B _{10d}	2,000,000 (ISO 13849-1 Annex C Table C.1)					
Mechanical durability	1,000,000 operations min. (GS-ET-19)					
	Rear unlocking button: 3,000 operations min. (Type SG-B2-□-L5)					
Electrical durability	100,000 operations min. (AC-12, 250 V 1 A)					
	1,000,000 operations min. (AC/DC 24 V 100 mA) (900 operations/hour)					
Electric shock protection class	Class II (IEC 61140) (Note 2),  (double-insulated)					
Interlock force	1,400 N min. (GS-ET-19) (Note 3) (500 N min. : SG-K24 actuator)					
Direct opening travel	11 mm 0.433 in min. (actuator: SG-K21)					
	12 mm 0.472 in min. (for other actuators)					
Direct opening force	80 N min.					
Contact resistance	700 mΩ max. (initial value, 5 m 16.404 ft cable)					
Protection	IP65 (IEC 60529)					
Shock resistance	Malfunction: 100 m/s ² , Destruction: 1,000 m/s ²					
Vibration resistance	Malfunction: 10 to 55 Hz, half amplitude 0.35 mm 0.014 in					
	Destruction: 30 Hz, half amplitude 1.5 mm 0.059 in					
Conditional short-circuit current	50 A (250 V)					
Short-circuit protective device	Use 250 V / 10 A fast acting type fuse					
Material	Enclosure: PA66					
Cable	UL style 2464, No.22 AWG 12-core					
Key	Operating specifications	2 positions				
	Mechanical durability	100,000 operations min.				
	Key operating durability	10,000 operations min.				
	Key tensile strength	1.0 N·m min.				
	Direct opening force	0.6 N·m min.				
	Direct opening degree	60° min.				
Weight	SG-B2-□-5 : Approx. 680 g, SG-B2-□-L5 : Approx. 700 g					

- Notes: 1) Ratings approved by UL, c-UL: 125 V
 2) Basic insulation of 2.5 kV impulse withstand voltage is ensured between different contact circuits.
 When both SELV (safety extra low voltage) or PELV (protective extra low voltage) circuits and other circuits (such as 230 V AC circuits) are used for the solenoid power and contact circuits at the same time, the SELV or PELV requirements are not met any more.
 3) The actuator locking strength is rated at 1,400 N of static load. Do not apply a load higher than the rated value. When a higher load is expected to work on the actuator, provide an additional system consisting of another safety switch without lock (such as the **SG-A1** safety switch) or a sensor to detect door opening and stop the machine.

PRECAUTIONS FOR PROPER USE

- This catalog is a guide to select a suitable product. Be sure to read the instruction manual attached to the product prior to its use.



- In order to avoid electric shock or fire, turn the power off before installation, removal, wire connection, maintenance, or inspection of the safety switch.
- If relays are used in the circuit between the safety switch and the load, consider the danger and use safety relays, since welding or sticking contacts of standard relays may invalidate the functions of the safety switch.
- Do not place a PLC in the circuit between the safety switch and the load. Safety and security can be endangered in the event of a malfunction of the PLC.
- Do not disassemble or modify the safety switch, otherwise a breakdown or an accident may occur.
- Do not install the actuator in a location where the human body may come in contact. Otherwise injury may occur.

- Regardless of door types, do not use the safety switch as a door stop. Install a mechanical door stop at the end of the door to protect the safety switch against excessive force.
- Do not apply excessive shock to the safety switch when opening or closing the door. A shock to the safety switch exceeding 1,000 m/s² may cause damage to the safety switch.
- If the operating atmosphere is contaminated, use a protective cover to prevent the entry of foreign objects into the safety switch through the actuator entry slots. Entry of a considerable amount of foreign objects into the safety switch may affect the mechanism of the safety switch and cause a malfunction.
- Cover the unused actuator entry slot using the slot plug supplied with the safety switch.
- Do not store the safety switches in a dusty, humid, or organic-gas atmosphere, or in an area subjected to direct sunlight.
- Use proprietary actuators only. When other actuators are used, the safety switch may be damaged. Do not cut, machine, or otherwise modify actuators. Doing so may cause equipment failure.
- Do not open the lid of the safety switch. Loosening the screws may damage the safety switch.
- The locking strength is rated at 1,400 N. Do not apply a load higher than the rated value. When a higher load is expected, provide an additional system consisting of another safety switch without lock or a sensor to detect door opening and stop the machine.
- Regardless of door types, do not use the safety switch as a door lock. Install a separate lock using a latch or other measures.
- Although the **SG-K21A** / **SG-K22A** actuators alleviate the shock when the actuator enters the slot on the safety switch, make sure that excessive shock is not applied. If the rubber bushings become deformed or cracked, replace with new ones.

PRECAUTIONS FOR PROPER USE

- Do not mount the safety switch facing down as shown in the figure below. Otherwise, the key may fall off due to shock.

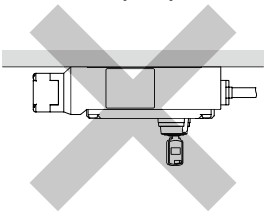

Cables

- Do not fasten or loosen the gland at the bottom of the safety switch.
- When bending the cable during wiring, make sure that the cable radius is kept at 30 mm 1.181 in minimum.
- When wiring, make sure that water or oil does not enter the cable.
- Do not open the lid of the safety switch. Otherwise the safety switch will be damaged.

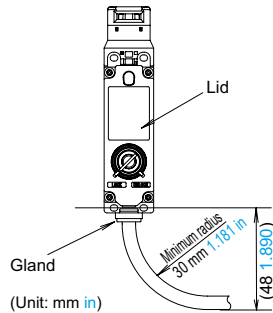

Minimum radius of hinged door

When using the safety switch on hinged doors, refer to the minimum radius of doors shown below. When using on doors with small minimum radius, use the angle adjustable actuator (SG-K24). Note: Because deviation or dislocation of hinged doors may occur in actual applications, make sure of the correct operation before installation.

When using the right-angle actuator (SG-K22)

<When the door hinge is on the extension line of the actuator mounting surface>

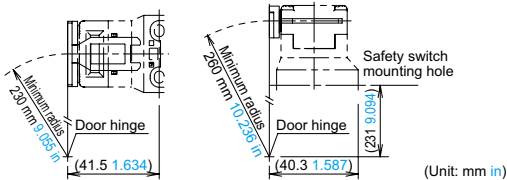

<When the door hinge is on the extension line of the safety switch surface>

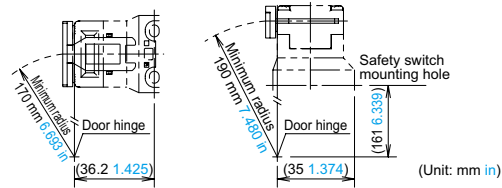

When using the right-angle actuator (with rubber bushings) (SG-K22A)

<When the door hinge is on the extension line of the actuator mounting surface>

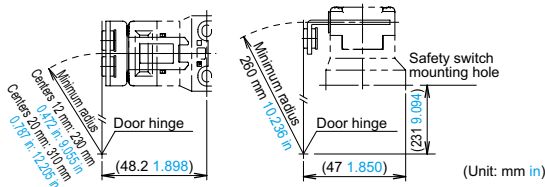

<When the door hinge is on the extension line of the safety switch surface>

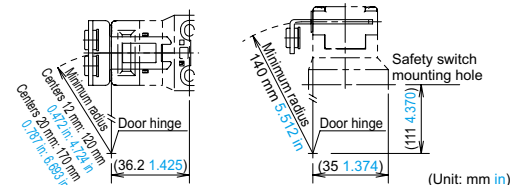

Actuator angle adjustment (vertical / horizontal)

- Using the angle adjustment screw (M3 hexagon-socket-head screw), the actuator angle can be adjusted. Adjustable angle: 0 to 20°
- The larger the adjusted angle of the actuator, the smaller the applicable radius of the door opening. After installing the actuator, open the door. Then adjust the actuator so that its edge can be inserted properly into the actuator entry slot of the safety switch.
- After adjusting the actuator angle, apply Loctite to the adjustment screw so that the screw will not move.

When using the angle adjustable actuator (SG-K24)

- When the door hinge is on the extension line of the actuator mounting surface: 70 mm 2.756 in
- When the door hinge is on the extension line of the safety switch surface: 50 mm 1.969 in

<When the door hinge is on the extension line of the actuator mounting surface>

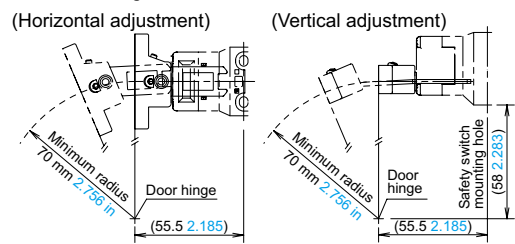

<When the door hinge is on the extension line of the safety switch surface>

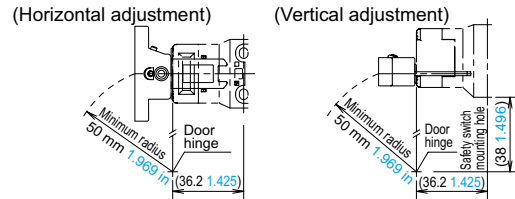

Mounting

- Mount the safety switch on a fixed piece of machinery or guard and the actuator on a hinged door. Avoid mounting both the safety switch and actuator on a hinged door. Doing so may cause equipment failure. For more information about how to mount the devices, see the following diagram:

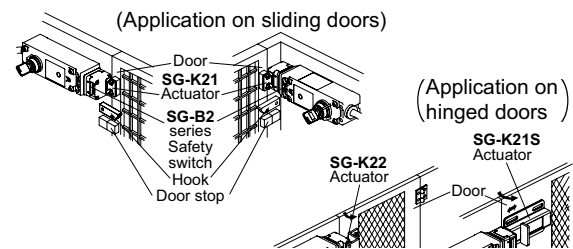

Recommended tightening torque for mounting screws

- Recommended screw tightening torque

	Screw tightening torque
For mounting the safety switch (M4 screw) (Note 1)	1.8 to 2.2 N·m
For mounting the actuator	
(SG-K21 : Two M4 screws) (Note 1)	1.8 to 2.2 N·m
(SG-K21A / SG-K22A : Two M4 screws) (Note 1, 2)	1.0 to 1.5 N·m
(SG-K21S : M5 screw) (Note 1)	4.5 to 5.5 N·m
(SG-K22 : Two M4 phillips screws)	0.8 to 1.2 N·m
(SG-K24 : Two M4 screws) (Note 1)	1.0 to 1.5 N·m
For mounting the SG-B2 head (M3)	0.9 to 1.1 N·m
For mounting the manual rear unlocking button (M3 screw with washers)	0.5 to 0.7 N·m

- Notes: 1) The above recommended tightening torques of the mounting screws are the values confirmed with hexagon-socket-head bolts. When other screws are used and tightened to a smaller torque, make sure that the screws do not come loose after mounting.
2) In the case of SG-K21A or SG-K22A, using two M4 screws and two attached washers, fasten the actuator securely on the door.

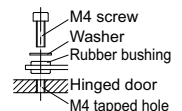

DIMENSIONS (Unit: mm in)

The CAD data in the dimensions can be downloaded from our website.

SG-B2-K2□-5

Door switch

When using vertical mounting / straight actuator (SG-K21)

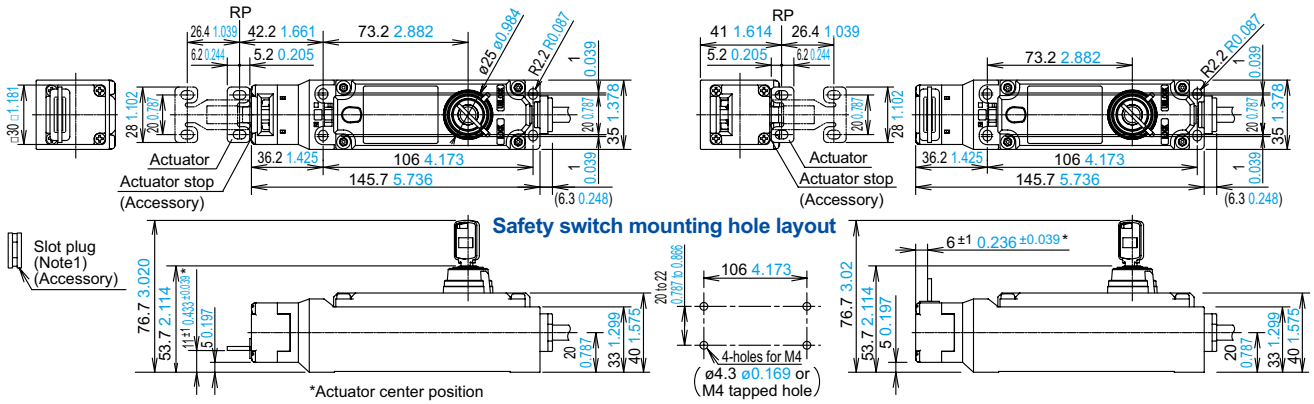

When using vertical mounting / straight actuator (SG-K22)

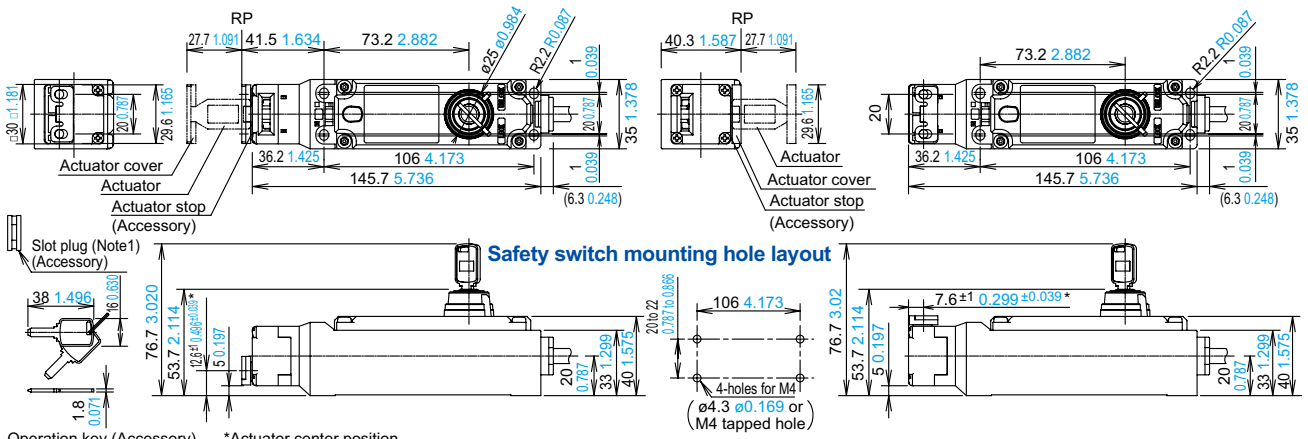

Notes: 1) Plug the unused actuator entry slot using the plug supplied with the switch.
2) When mounting the safety switch, be sure to conform to the mounting hole dimensions and secure in place with four screws.

SG-B2-K□-L5

Door switch (rear unlocking button type)

When using horizontal mounting / straight actuator (SG-K21)

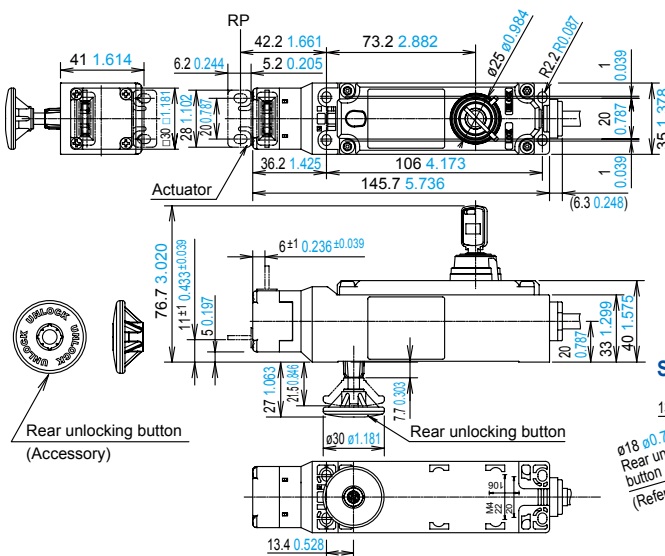

- Mounting part thickness (X): 1 to 6 mm 0.039 to 0.236 in
 6 < X < 23 mm 0.236 < X < 0.906 in : Not mountable
 23 ≤ X ≤ 53 mm 0.906 ≤ X ≤ 2.087 in : Use a rear unlocking button kit. (refer to page 5, 11)
 * The mounting part is a frame or a panel that the product is mounted on.

- With the mounting hole dimension, the rear unlocking button rod does not touch the hole even when the safety switch moves sideways.
 Note: Plug the unused actuator entry slot using the plug supplied with the switch.

Actuator mounting reference position

As shown in the figure on the right, the mounting reference position of the actuator when inserted in the safety switch is:

The actuator stop on the actuator lightly touches the safety switch.
 * The actuator stop is used to adjust the actuator position. Remove the actuator stop after the actuator position is mounted.

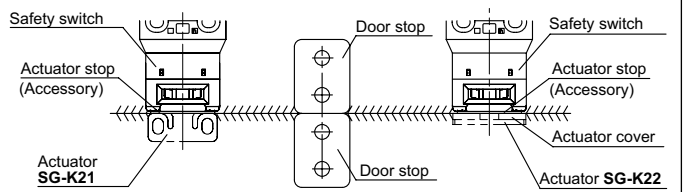

DIMENSIONS (Unit: mm in)

The CAD data in the dimensions can be downloaded from our website.

SG-K2

Actuator

Straight actuator (SG-K21)

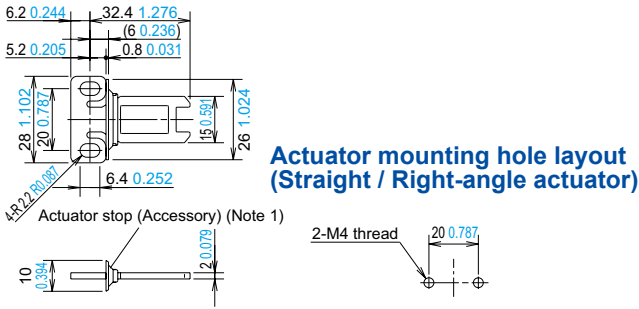

Right-angle actuator (SG-K22)

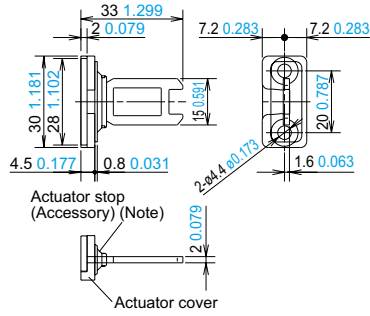

Straight actuator with rubber bushings (SG-K21A)

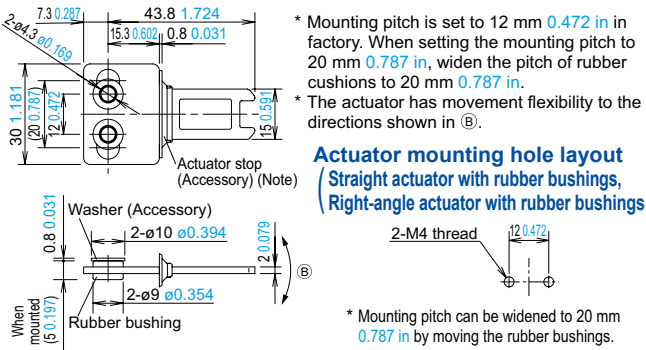

Right-angle actuator with rubber bushings (SG-K22A)

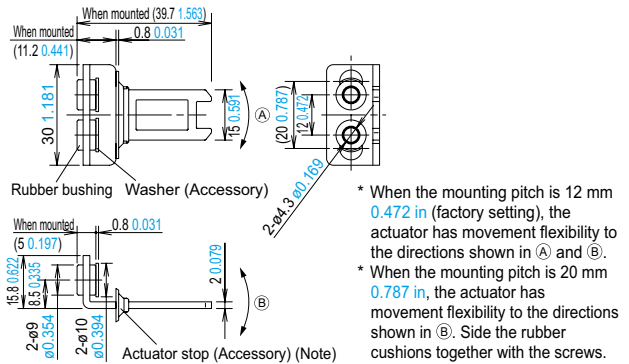

Slide actuator (SG-K21S)

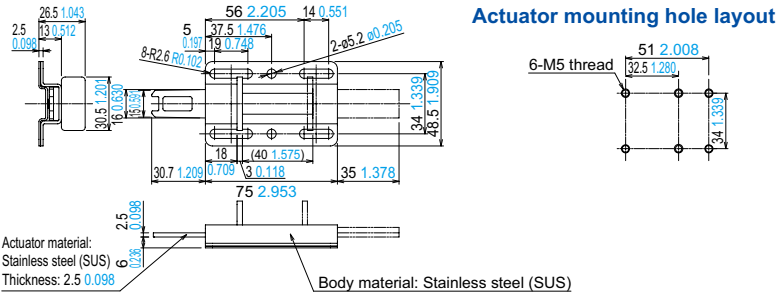

Horizontal / Vertical angle adjustable actuators (SG-K24)

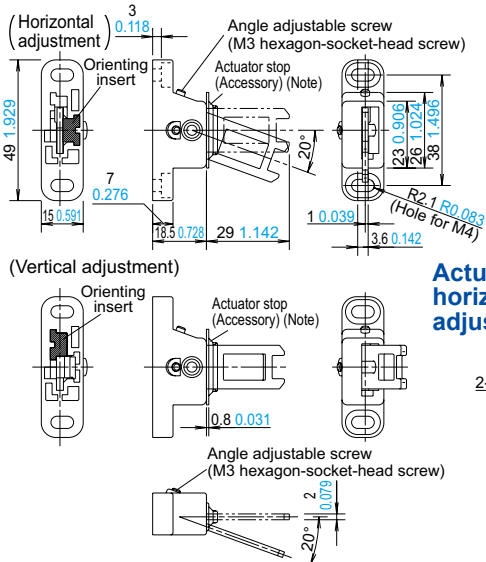

Changes in the orientation of adjustment for angle adjustable (vertical / horizontal) actuators

The orientation of adjustment of angle adjustable (vertical / horizontal) actuators is determined by the position in which the orienting insert (white plastic) is installed on the back of the actuator.

Install the insert according to the desired orientation of adjustment.

Exercise care not to lose the orienting insert. The actuator will not operate properly without the orienting insert.

SG-PH2

Padlock hasp (Optional)

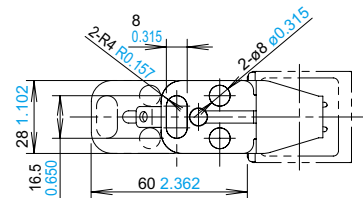

Note: The actuator stop is used to adjust the actuator position. Remove the actuator stop after the actuator position is mounted.

DIMENSIONS (Unit: mm in)

The CAD data in the dimensions can be downloaded from our website.

MS-SG21

Mounting plate (Optional)

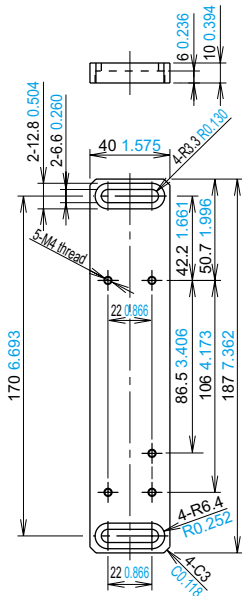

Mounting plate hole layout

When installing the **SG-B2-K2□-L5** (rear unlocking button type), provide a rear unlocking button hole on the **MS-SG-21**.

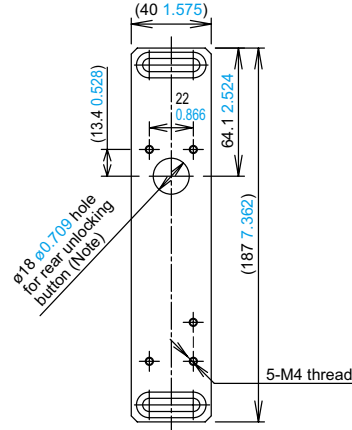

Safety switch mounting hole layout

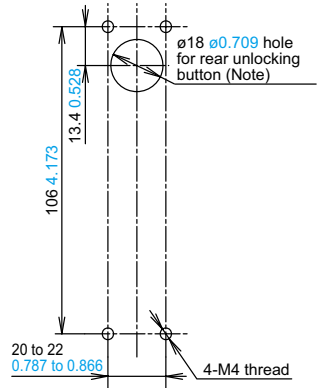

Note : With the mounting hole dimension, the rear unlocking button rod does not touch the hole even when the safety switch moves sideways.

MS-SG-22 / MS-SG-23

Rear unlocking button kit for a frame (Optional)

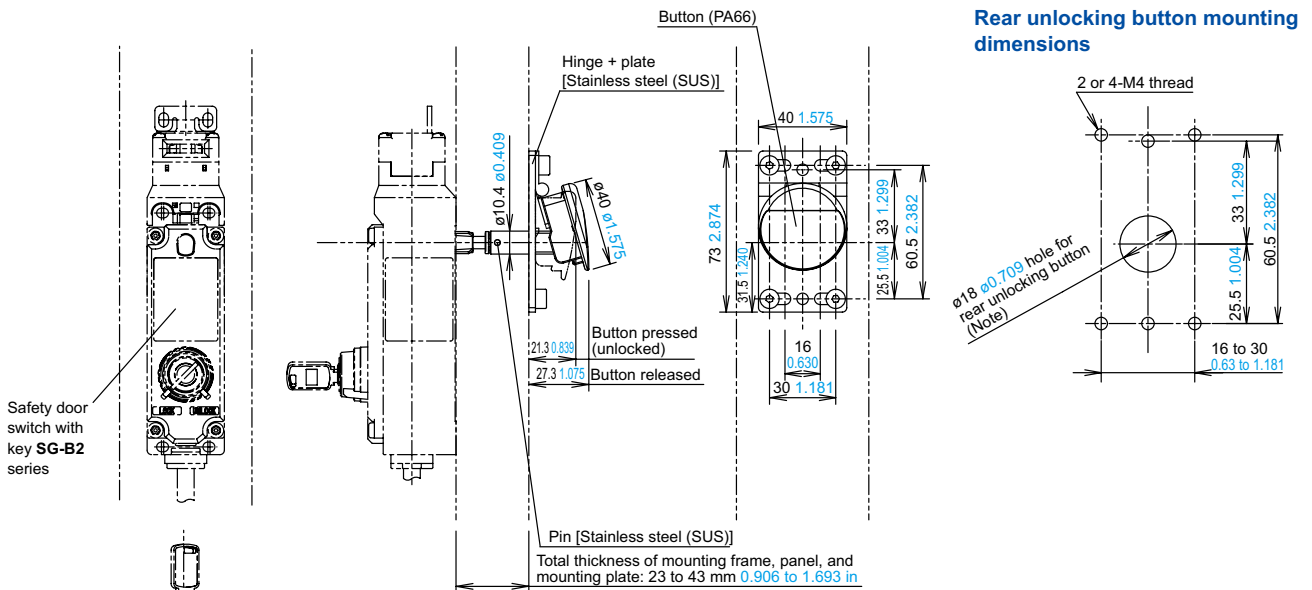

Rear unlocking button mounting dimensions

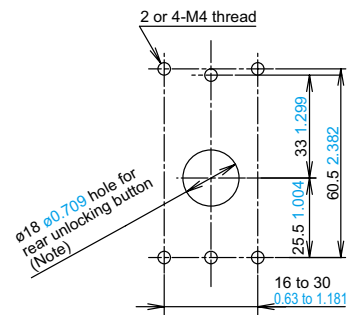

Example : When mounted on a □30 mm □1.181 in frame using the mounting plate above **MS-SG-21**, select **MS-SG-22** since the mounting part thickness (X) is 40 (X = 10 + 30 = 40) 1.575 (X = 0.394 + 1.181 = 1.575). For more information about selecting a back manual unlocking button kit for a frame, see the following table:

Model No.	Mounting part* thickness (X) (mm in)
	Rear unlocking button type When installing an SG-B2-K2□-D-L5 with a rear unlocking button directly
MS-SG-22	33 < X ≤ 43 1.299 < X ≤ 1.693
MS-SG-23	23 < X ≤ 33 0.906 < X ≤ 1.299

* The mounting part is a frame or a panel that the product is mounted on.

Note : With the mounting hole dimension, the rear unlocking button rod does not touch the hole even when the safety switch moves sideways.

Disclaimer

The applications described in the catalog are all intended for examples only. The purchase of our products described in the catalog shall not be regarded as granting of a license to use our products in the described applications. We do NOT warrant that we have obtained some intellectual properties, such as patent rights, with respect to such applications, or that the described applications may not infringe any intellectual property rights, such as patent rights, of a third party.

Panasonic
INDUSTRY

Panasonic Industry Co., Ltd.

Industrial Device Business Division
7-1-1, Morofuku, Daito-shi, Osaka 574-0044, Japan
industrial.panasonic.com/ac/e/