

4

3

2

DWG NO.	SH	REV
GE-2093	1	B

1

PROPRIETARY NOTICE: THE INFORMATION CONTAINED IN THIS DOCUMENT IS PROPRIETARY TO AMPHENOL AND SHALL NOT BE DISCLOSED IN WHOLE OR IN PART IN ANY FORM OR FOR ANY REASON EXCEPT AS EXPRESSLY STATED IN WRITING BY AMPHENOL.

NOTES:

1. CONTINUOUS OPERATING TEMPERATURE: -40° TO 150°C
2. CONNECTOR: METRI-PACK 150.2 OR GT150 3.5mm  MATING APTIV(DELPHI) PART NUMBER: 12162193, 15336004 OR EQUIVELENT
3. VOLTAGER : 5V

TEMP (°C)	RESISTANCE (OHMS)	RES TOL (+%)	RES TOL (-%)
-40°C	101770	5.74	9.27
25°C	2820	5.15	4.86
50°C	988.1	NOMINAL	
100°C	179.6	2.82	2.51
125°C	89.11	2.96	3.46

REVISIONS			
REV	REVISION HISTORY	DATE	DWN APVD
A	INITIAL DRAFT	5/30/19	MED STS
B	UPDATED RvT TABLE	02/07/19	JNJ STS

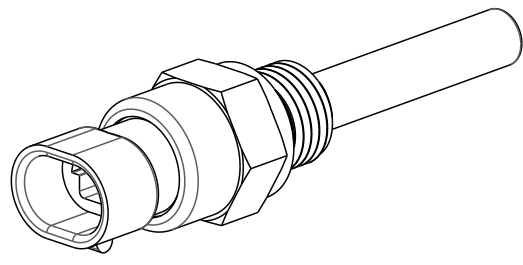
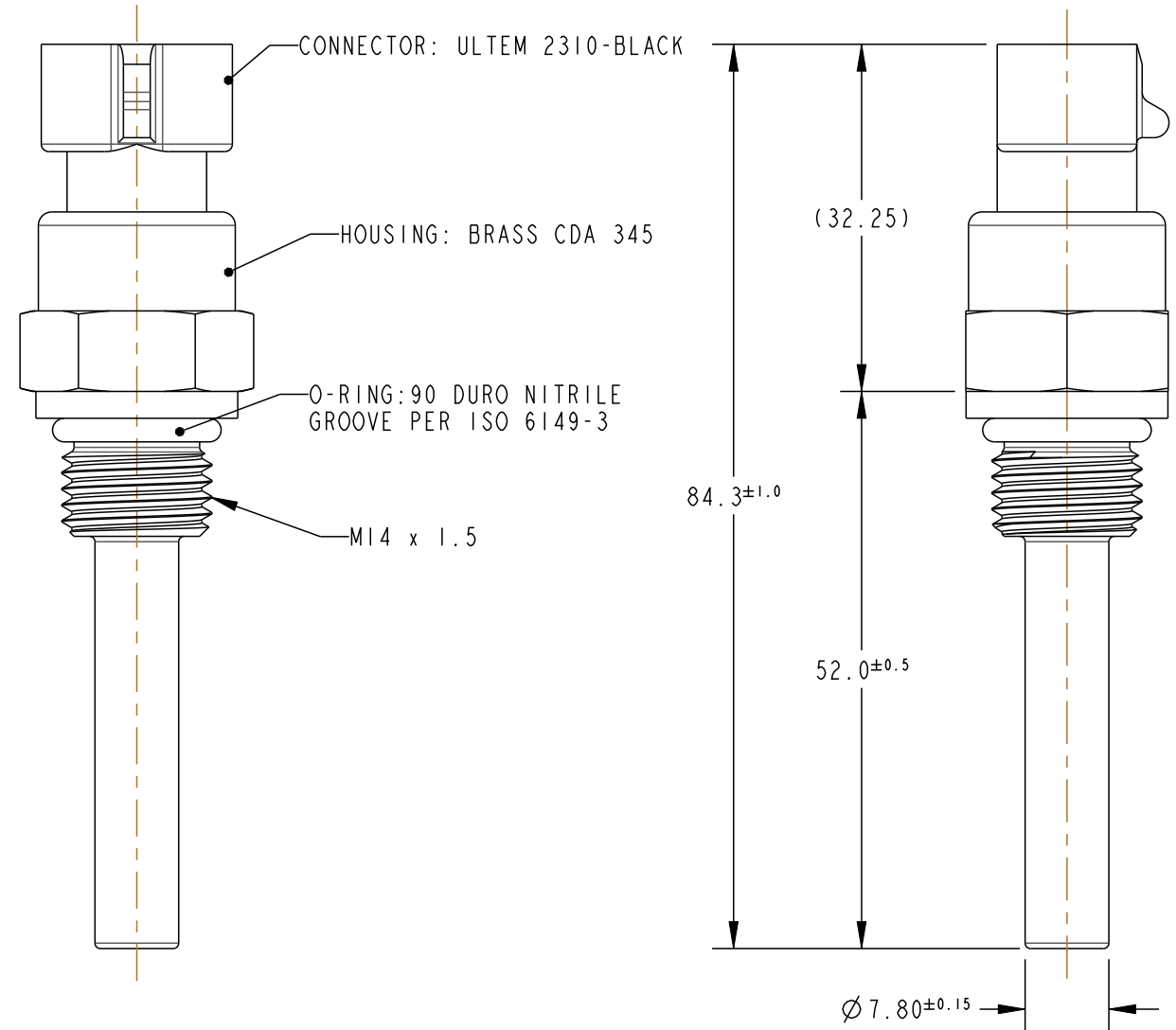
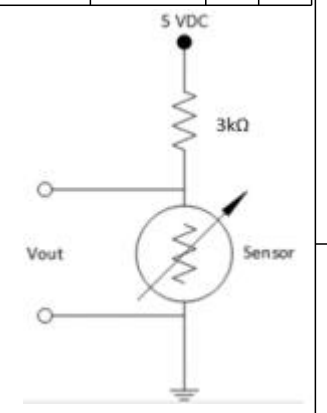
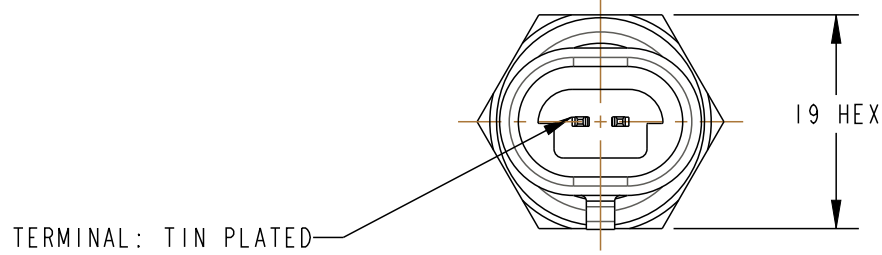

SCALE 1:1

Amphenol
Advanced Sensors St. Marys, PA 15857

TITLE: **FLUID TEMPERATURE SENSOR**

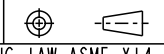
UNLESS OTHERWISE SPECIFIED DIMENSIONS ARE IN MM TOLERANCES ARE: .X ± 0.5 .XX ± 0.25	APPROVALS	DATE
	DRAWN MED	05/30/2019
ANGLES ± 2°	CHECKED STS	05/30/2019
	ENGR JJD	05/30/2019
THIRD ANGLE PROJECTION 	OC	
INTERPRET DRAWING IAW ASME Y14.5	MFG	
MATERIAL SEE DRAWING		

DO NOT SCALE DRAWING

SIZE **B** DWG NO. **GE-2093** REV **B**

SCALE 3:2 SHEET 1 OF 1

LEGAL NOTICE - THIS DRAWING AND ANY INTELLECTUAL PROPERTY RIGHTS THERE IN ARE PROPERTY OF AMPHENOL AND NO LICENSES ARE GRANTED UNDER THOSE RIGHTS.

4

3

2

1