

Schematic:

REV.	ECN NO.	DESCRIPTION	DATE	APPD
A	REL		2009-12-14	

PC BOARD CONNECTIONS

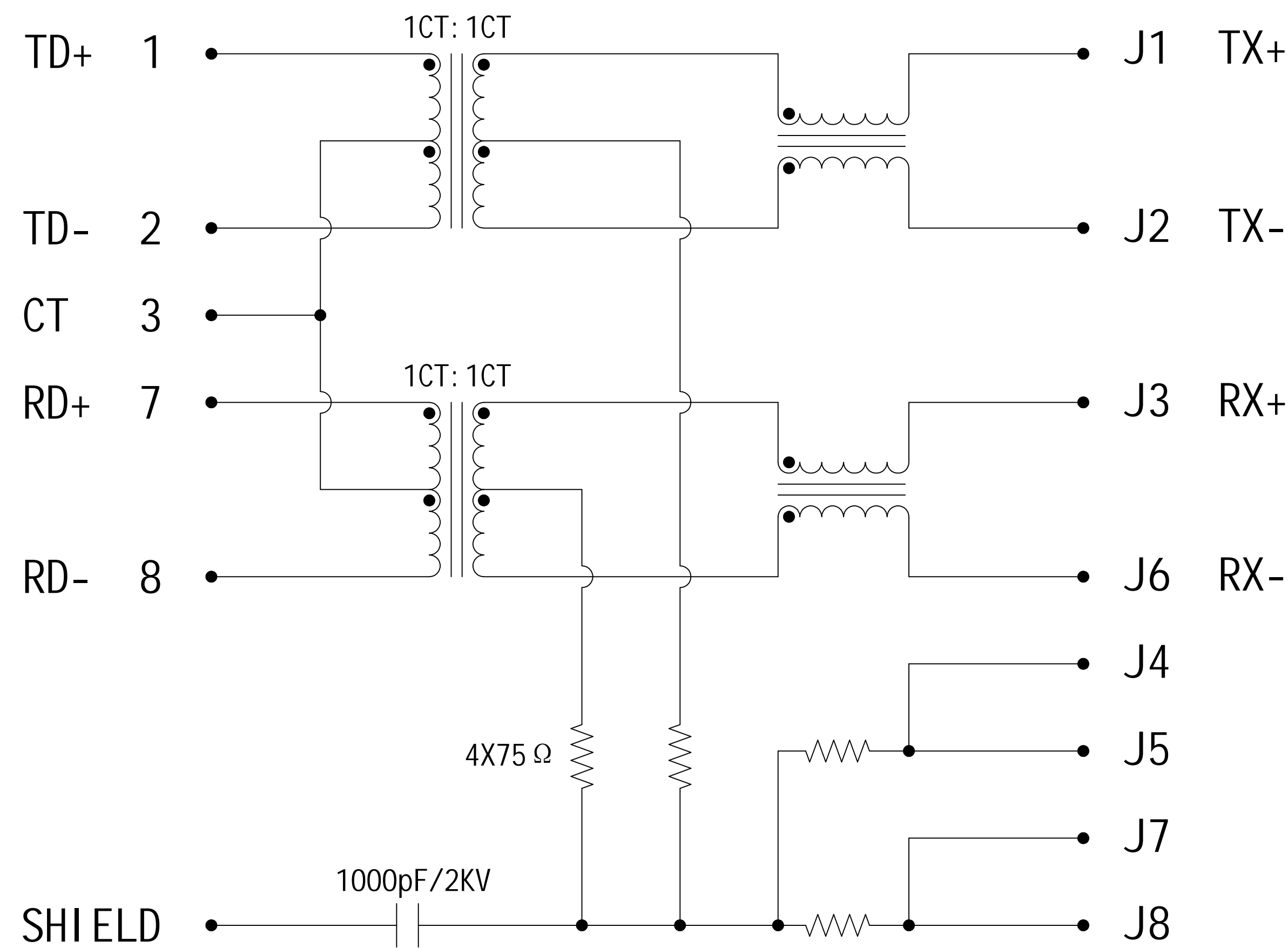

RJ45 CONNECTOR

ELECTRICAL SPECIFICATIONS @25°C

- Turn Ratio: 1CT:1CT ±5%
- OCL: 350uH Min @100KHz, 0.1V, 8mA DC Bias
- Insertion Loss (dB Max):
1-100MHz: -1.2
- Return Loss(dB Min):
1-30MHz: -16 30-60MHz: -12
60-80MHz: -10 80-100MHz: -8
- Cross Talk(dB Min):
1-100MHz: -30
- Common Mode Rejection(dB Min):
1-100MHz: -30
- Isolation PHY SIDE To Line SIDE : 1500Vrms
- Operating Temperature Range: 0°C ~ +70°C.

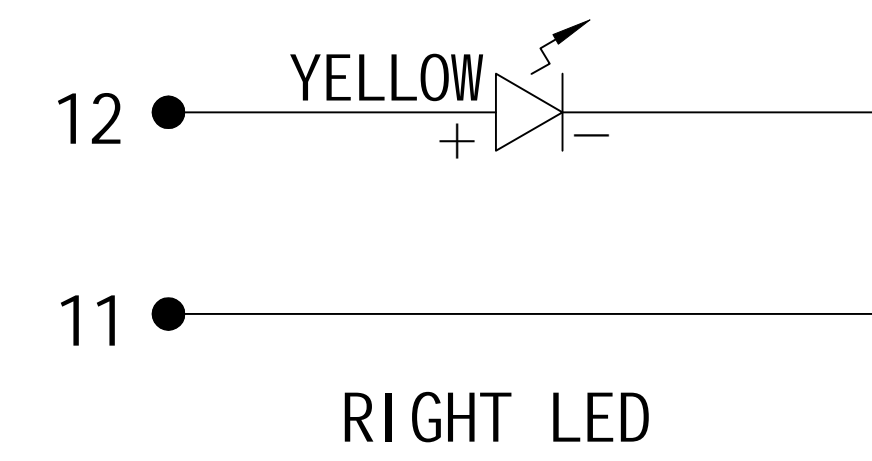
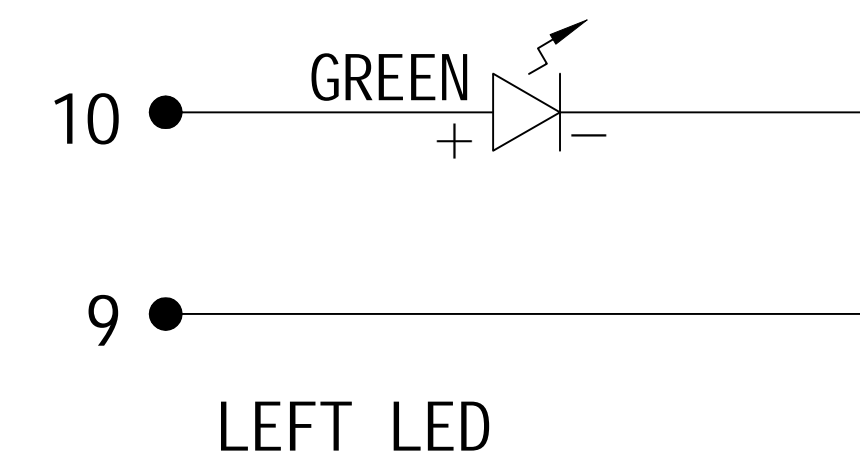

EMITTING COLOR	λ p(nm)	VF @IF=20mA	IR @VR=5V
GREEN	565	1.8~2.6V	10 μA max
YELLOW	585	1.8~2.6V	10 μA max



X.X	±0.30	APPD: TOM	LINK-PP INT'L TECHNOLOGY CO., LIMITED	
X.XX	±0.25	CHKD: JAMES	TITLE:	
X.XXX	±0.15	DR: JULY	RJ45 CONNECTOR WITH 10/100 BASE-T INTEGRATED MAGNETICS & WITH EMI SPRING FINGER & WITH LED	
ANGLES	±1°	UNIT: mm	PART NO.:	LPJ0013AHNL
	SCALE: 2/1	SHEET: 1/2	REV: A	DWG NO.: LP09121435

Mechanical :

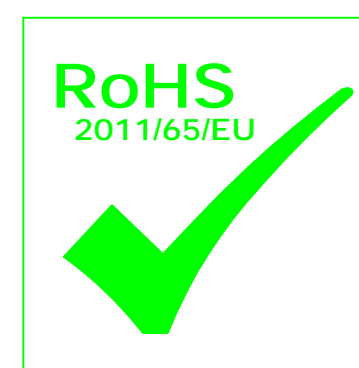
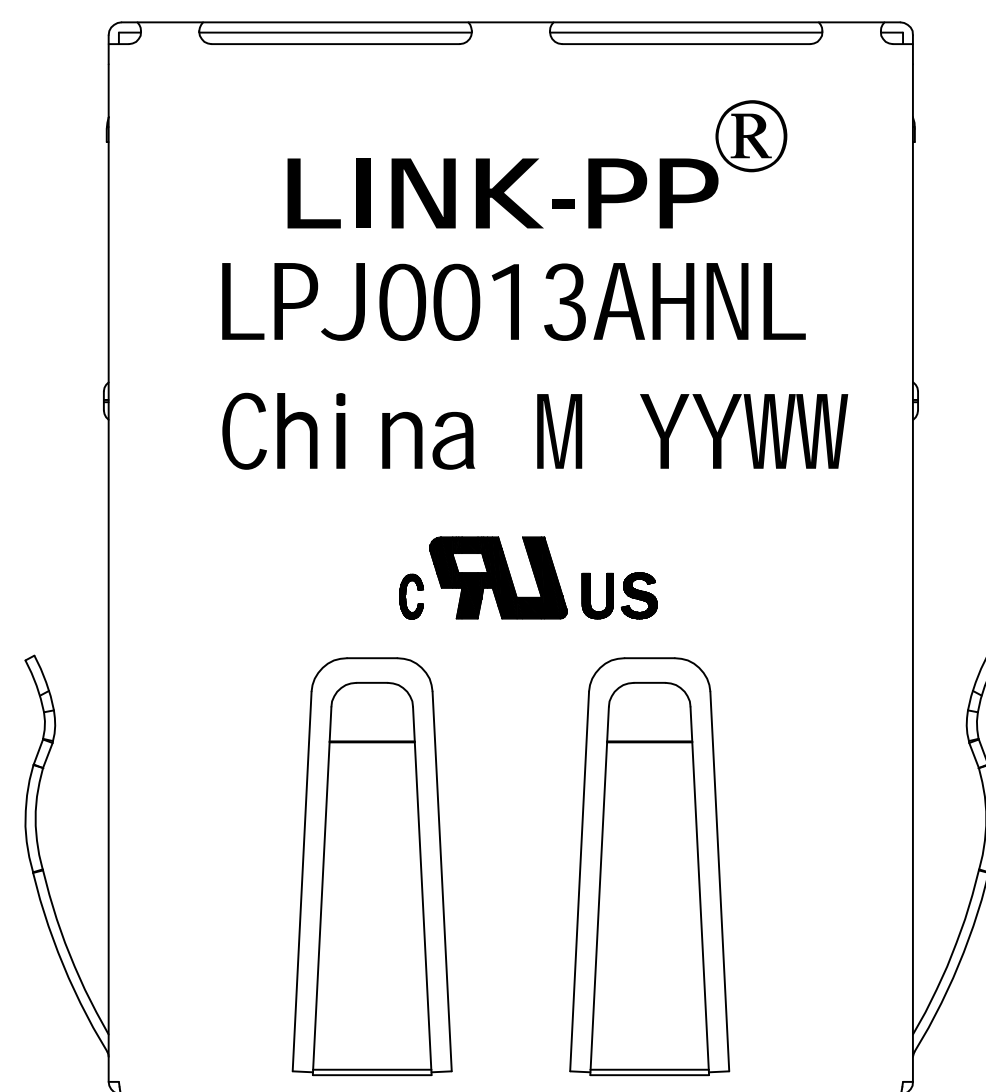
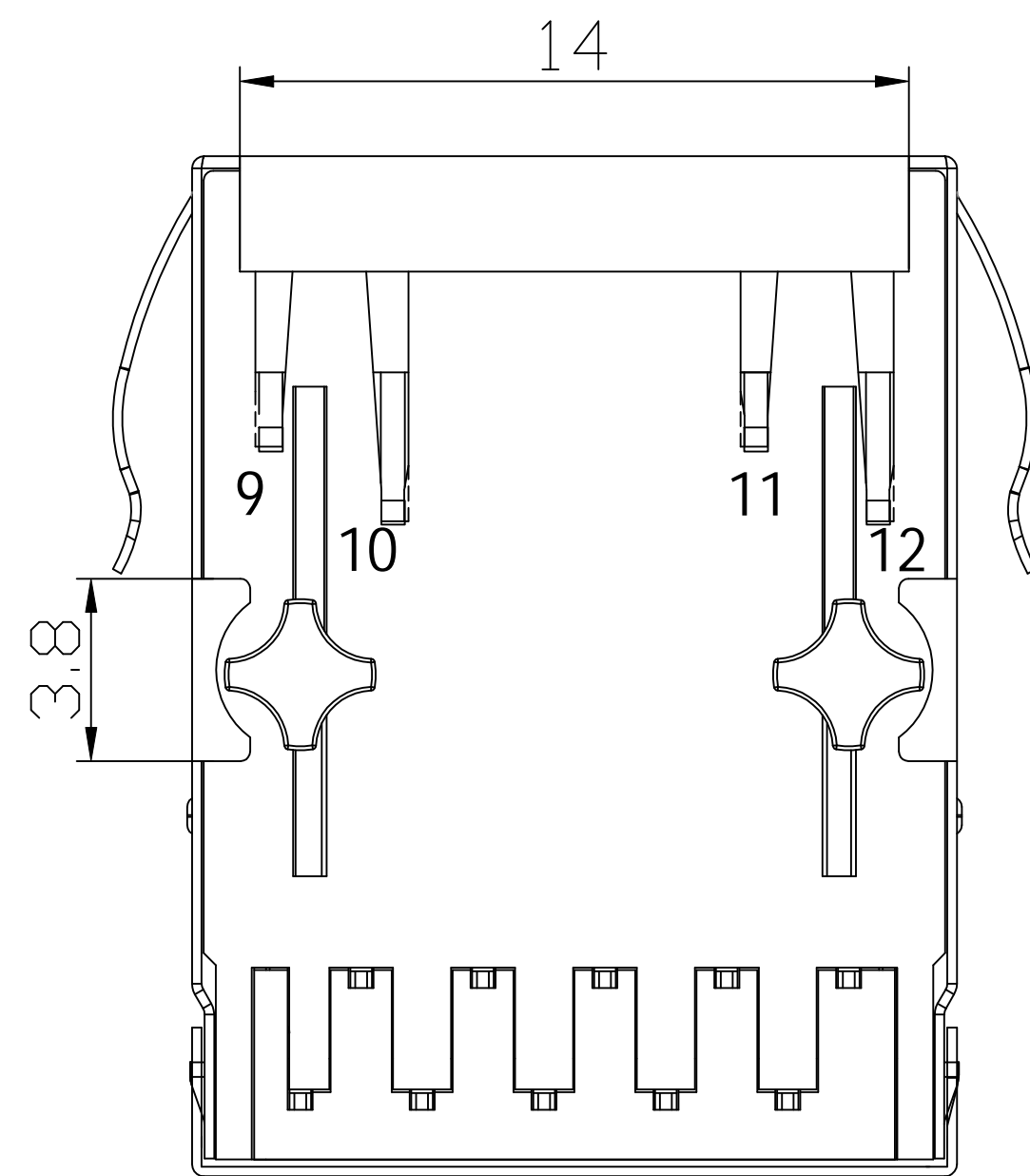
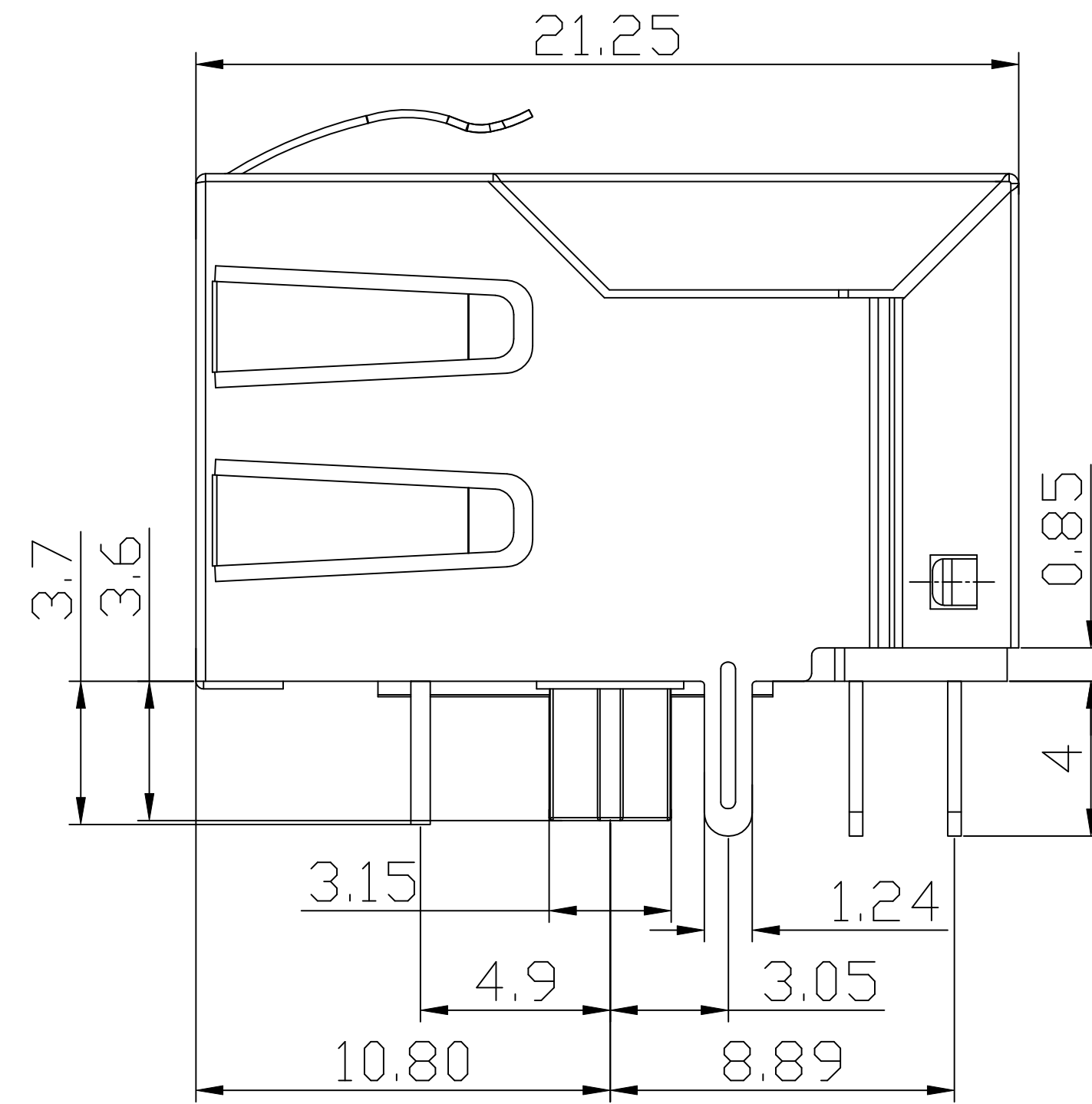
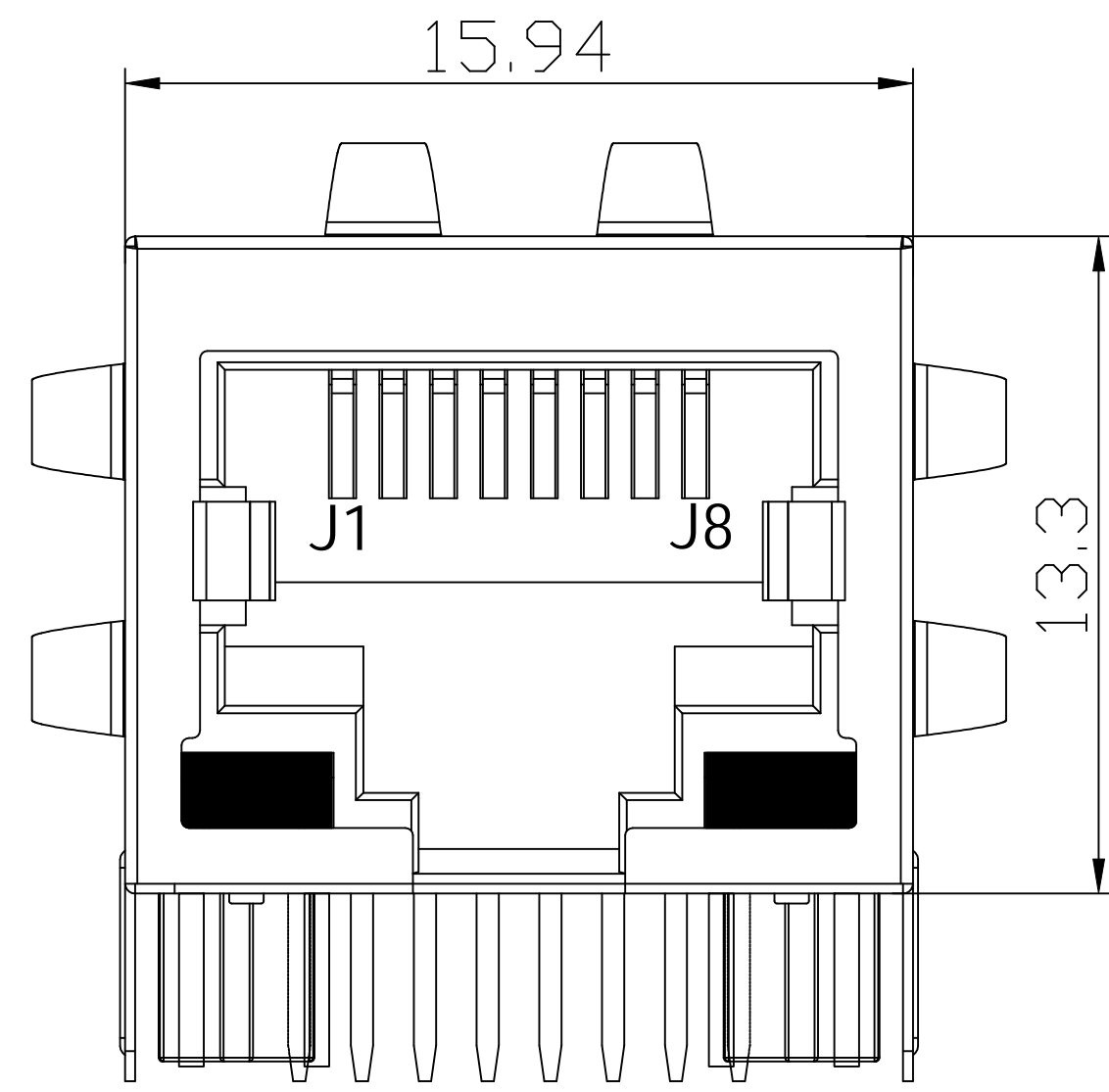

REV.	ECN NO.	DESCRIPTION	DATE	APPD
A	REL		2009-12-14	

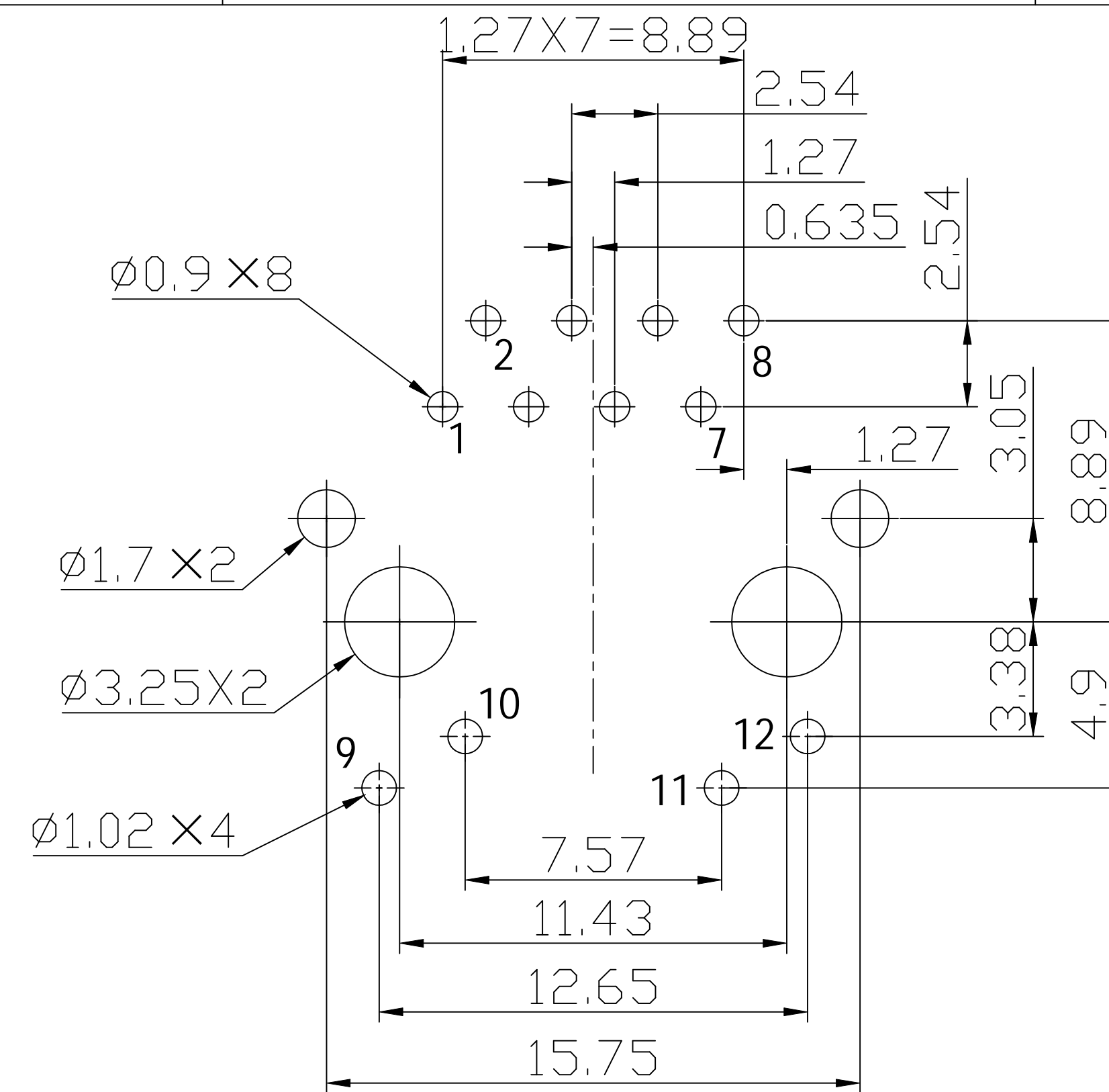

NOTES:

RECOMMENDED PCB LAYOUT(TOP VIEW)

1. Designed to support application, such as SOHO(ADSL modems), LAN-on-Motherboard(LOM), hub and Switches.
2. Meets IEEE802.3 specification.
3. Connector Materials:
 Housing: Thermoplastic PBT+30%G.F UL94V-0
 Contact: Phosphor Bronze C5210R-EH Thickness=0.35mm
 Pins: Brass C2680R-H Thickness=0.35mm
 Shield: SUS 304-1/2H Thickness=0.2mm
 Contact plating: Gold 6 micro-inches min. In contact area.
4. Wave solder tip temperature and time: 250°C, 5 Sec.
5. UL Certification: File Number E484635.

X.X	±0.30	APPD: TOM	LINK-PP INT'L TECHNOLOGY CO., LIMITED	
X.XX	±0.25	CHKD: JAMES	TITLE:	
X.XXX	±0.15	DR: JULY	RJ45 CONNECTOR WITH 10/100 BASE-T INTEGRATED MAGNETICS & WITH EMI SPRING FINGER & WITH LED	
ANGLES	±1°	UNIT: mm	PART NO.:	LPJ0013AHNL
		SCALE: 2/1	SHEET: 2/2	REV: A
			DWG NO.:	LP09121435