

REV.	ECN NO.	DESCRIPTION	DATE	DESIGN

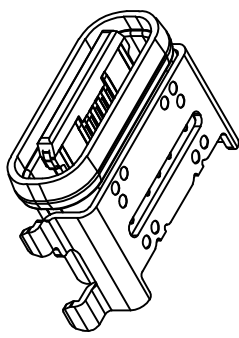

NOTES:

- 1.MATERIAL SPECIFICATION:
 1-1.HOUSING:High-Temp. Plastics,U194V-0,Color:Black.
 1-2.CONTACTS:Copper Alloy T=0.25mm.
 1-3. OUTER SHELL:Stainless Steel,T=0.30mm.
 1-4.INNER SHELL:Stainless Steel,T=0.20mm.
 1-5.MID-PLATE:Stainless Steel,T=0.20mm.
 1-6.SOLDER-PLATE:Stainless Steel,T=0.10mm.
 2.PLATING SPECIFICATION:
 2-1.CONTACTS:
 Ni UNDERPLATED OVER ALL;
 Gold Plated On Contact Area;
 Gold Flash Plated On Solder Area.
 2-2.SHELL:
 Ni UNDERPLATED OVER ALL;
 Gold Flash Plated ON Solder Leg.
 3.ROHS AND HF COMPLIANT.
 4.MECHANICAL PERFORMANCE:
 4-1.MATING FORCE:6~20N(Initial);5~20N(After)
 4-2.UNMATING FORCE:8~20N(Initial);6~20N(After)
 4-3.DURABILITY:10000 CYCLES.
 5.ELECTRICAL PERFORMANCE:
 5-1.CURRENT RATING:3A,VOLTAGE RATING:5.0V
 5-2.LLGR:
 VBUS & GND PINS:40mΩH/PIN MAX.;;
 OTHERS PINS:40mΩH/PIN MAX.;
 LLCR MAX. CHANGE OF ALL PINS:20mΩE.
 5-3.INSULATION RESISTANCE:100ME MIN.
 5-4.DIELECTRIC WITHSTANDING VOLTAGE:
 100V AC FOR 1 MINUTE.
 6.ENVIRONMENTAL PERFORMANCE:
 6-1.OPERATING TEMPERATURE:-20℃~+85℃.
 7.RECOMMENDED PROCESS:
 THE PEAK TEMPERATURE ON THE BOARD SHALL MAINTAIN 10±1 SECONDS AT 255±5℃.

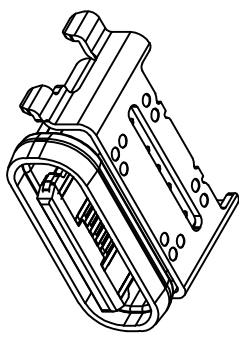
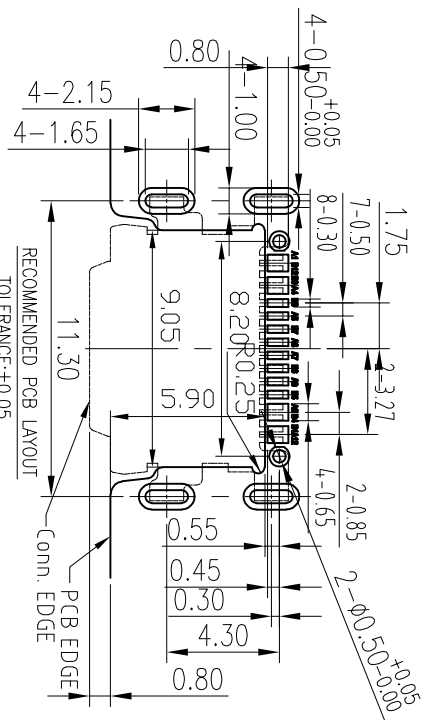

Pin Assignments

Contact Number	Signal Name	Contact Number	Signal Name
A1	GND	B12	GND
A4	VBUS	B9	VBUS
A5	CC1	B8	SBUS2
A6	Dp1	B7	Dn2
A7	Dn1	B6	Dp2
A8	SBU1	B5	CC2
A9	VBUS	B4	VBUS
A12	GND	B1	GND

TOLERANCE		NAME(INTENDED USE)		FUYOU 广东富盈兴业精密科技实业有限公司 Guangdong FUYOU Precision Electronic Technology Co.,Ltd.
X.X ±0.30	X.X' ±10'	CUSTOMER DRAWING		
XX ±0.20	X' ± 8'	PART NO.	TITLE:	
.XXX ±0.10	.XX' ± 5'	FY23-012TC161F268-13	CP 16P防水沉板L.13	
UNITS mm	DESIGN: ZXHM	DRAWG NO.	FY23-012TC161F268-13	
MATERILA	CHED:	SCALE	SHEET	
FINISH	APPD:	1:1	1/2	
			REV.	
			A	

CUSTOMER

REV.	ECN NO.	DESCRIPTION	DATE	DESIGN

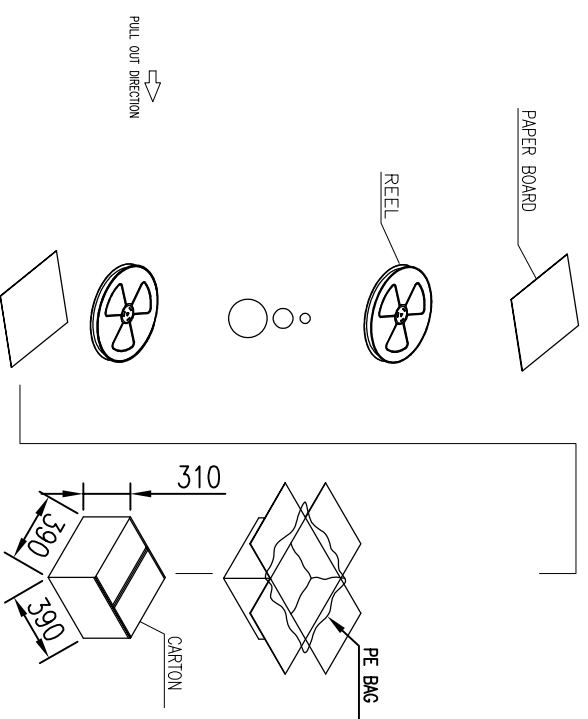
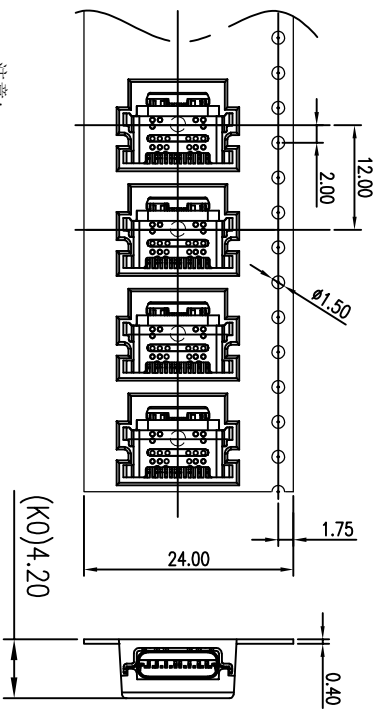
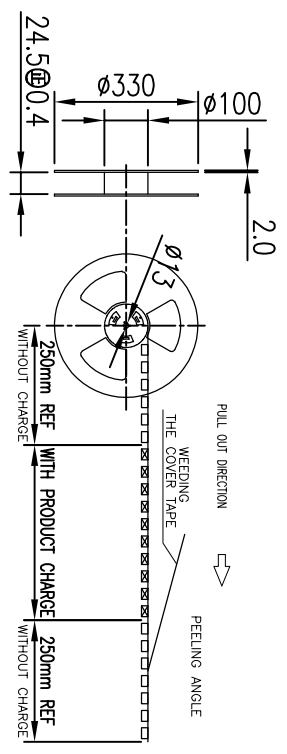

NOTE:
1. QUANTITY: 1000 PCS/REEL, 5000PCS/CARTON.

- 注意:
1. 材料:
纸箱: 纤维板, 瓦楞, 双层壁。
胶带: 聚乙烯, 耐热温度: 120°C, 白。
卷筒: 聚乙烯, 耐热温度: 70°C, 蓝色。
包装: 聚乙烯, 耐热温度: 100°C。
 2. 剥离速度: 0.1 ~ 1.3 N (10 ~ 130克)
 3. 脱皮速度: 300mm /min。
 4. 每个袋子都应包括干燥剂*1。
 5. 外箱上贴号物料标签及RoHS标签
 6. 同一产品只能装同一纸箱; 不允许其它产品;
 7. 包装后, 产品朝合面朝内;



TOLERANCE		NAME (INTENDED USE) CUSTOMER DRAWING		FYNGU 广东富盈兴业精密科技实业有限公司 Guangdong FYNGU Precision Electronic Technology Co., Ltd.	
X.X ±0.30	X.* ±10'	PART NO.	TITLE:	DRAWG NO.	
.XX ±0.20	.X' ± 8'	FY23-012TC161F268-13	CP 16P防水沉板1.13	FY23-012TC161F268-13	
.XXX ±0.10	.XX' ± 5'	DESIGN:	ZXM	SCALE	SHEET
UNITS	mm	CHED:		1:1	1/2
MATERILA	----	APPD:		REV.	A
FINISH	-----				