

SURFACE MOUNT SCHOTTKY BARRIER RECTIFIER

Reverse Voltage - 20 to 200 Volts Forward Current - 5.0 Ampere

Features

- Metal silicon junction, majority carrier conduction
- For surface mounted applications
- Low power loss, high efficiency
- High forward surge current capability
- For use in low voltage, high frequency inverters, free wheeling, and polarity protection applications

DO-221AA/SMBF **RoHS COMPLIANT**

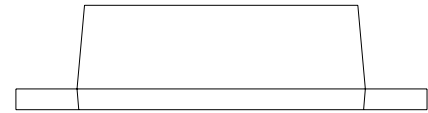
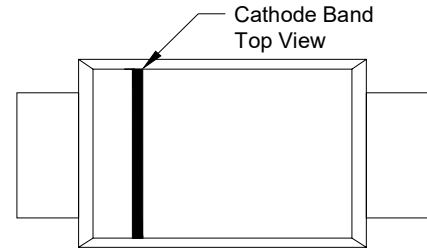

Mechanical Data

Case : DO-221AA/SMBF molded plastic body

Terminals :Solderable per MIL-STD-750,Method2026

Polarity : Cathode line denotes the cathode end

Position: Any

Approx. Weight : 0.0057g / 0.002oz

Equivalent circuit



Absolute Maximum Ratings and Electrical characteristics

Ratings at 25 °C ambient temperature unless otherwise specified.Single phase, half wave, 60Hz resistive or inductive load, apacitive load,derate by 20 %

Parameter	SYMBOLS	SS52BF	SS54BF	SS56BF	SS58BF	SS510BF	SS512BF	SS515BF	SS520BF	UNITS
		SS52BF	SS54BF	SS56BF	SS58BF	SS510BF	SS512BF	SS515BF	SS520BF	
Maximum repetitive peak reverse voltage	V_{RRM}	20	40	60	80	100	120	150	200	V
Maximum RMS voltage	V_{RMS}	14	28	42	56	70	84	105	140	V
Maximum DC blocking voltage	V_{DC}	20	40	60	80	100	120	150	200	V
Maximum average forward rectified current	$I_{F(AV)}$	5.0								A
Peak forward surge current 8.3ms single half sine-wave superimposed on rated load (JEDEC Method)	I_{FSM}	120								A
Maximum instantaneous forward voltage at 5.0A	V_F	0.55		0.70	0.85		0.95		V	
Maximum DC reverse current at rated DC blocking voltage $T_A=25^{\circ}C$ $T_A=125^{\circ}C$	I_R	1.0								mA
		50								
Typical junction capacitance (NOTE 1)	C_J	800			500					pF
Typical thermal resistance (NOTE 2)	$R_{\theta JA}$	45								°C/W
Operating junction temperature range	T_J	-55 to +150								°C
Storage temperature range	T_{STG}	-55 to +150								°C

Note:1.Measured at 1MHz and applied reverse voltage of 4.0V D.C.

2.PC.B.mounted with 0.2"X0.2"(5 X5 mm) copper pad areas.

Typical Characteristics

Fig.1 Forward Current Derating Curve

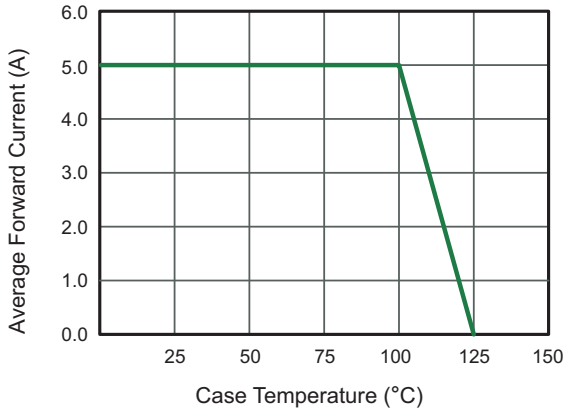

Fig.2 Typical Reverse Characteristics

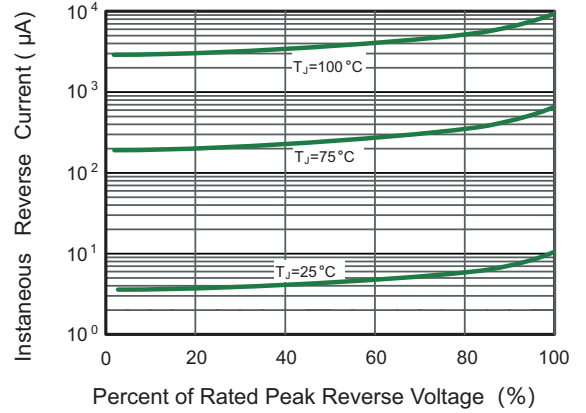

Fig.3 Typical Forward Characteristic

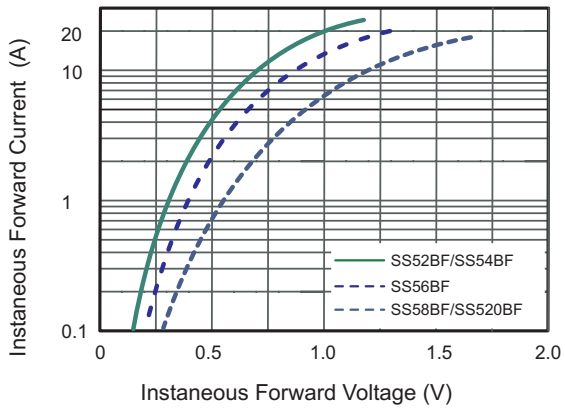

Fig.4 Typical Junction Capacitance

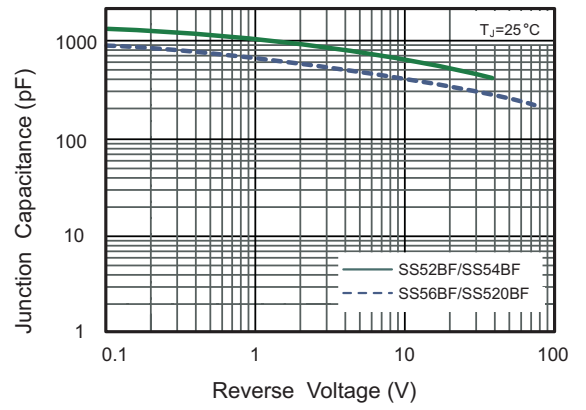

Fig.5 Maximum Non-Repetitive Peak Forward Surge Current

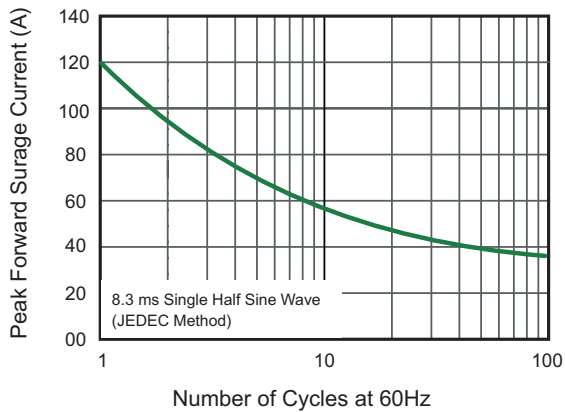
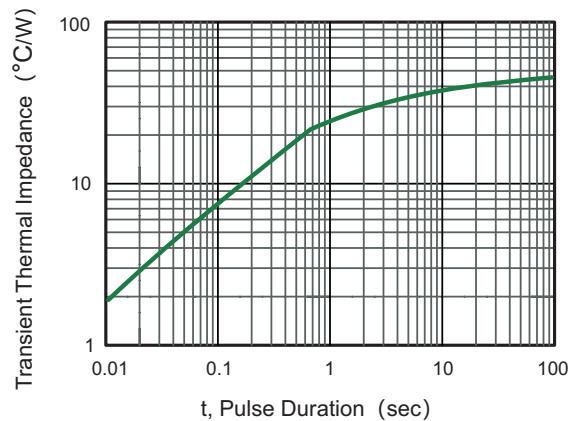
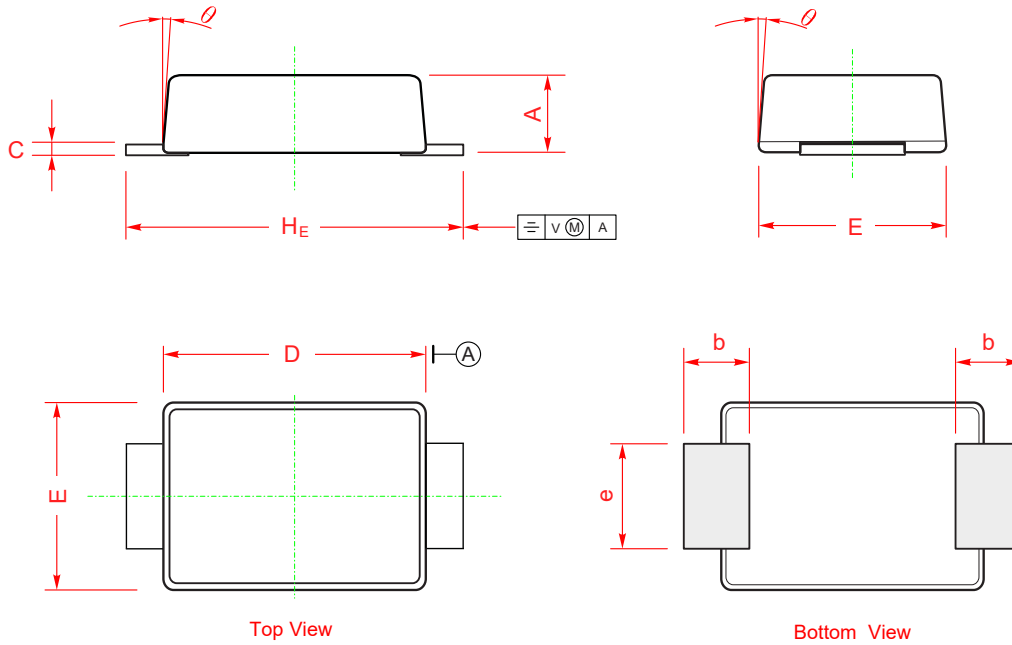

Fig.6- Typical Transient Thermal Impedance



DO-221AA/SMBF Package Outline Dimensions



Symbol	Dimensions In Millimeters		Dimensions In Inches	
	Min	Max	Min	Max
A	1.10	1.30	0.043	0.051
c	0.18	0.26	0.007	0.010
D	4.20	4.40	0.165	0.173
E	3.50	3.70	0.138	0.146
e	1.90	2.20	0.074	0.087
b	0.80	1.20	0.031	0.047
HE	5.10	5.50	0.201	0.217
θ	9° REF		9° REF	

DO-221AA/SMBF Suggested Pad Layout

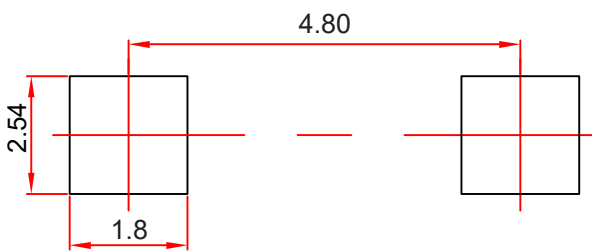

- Note:
1. Controlling dimension: in/millimeters.
 2. General tolerance: ± 0.05 mm.
 3. The pad layout is for reference purposes only.