

浙江汇隆晶片技术有限公司

Zhejiang Huilong Crystals Technology Co.,Ltd

SPECIFICATION FOR APPROVAL

CUSTOMER _____



NOMINAL FREQUENCY _____ 26.000000 MHz _____

HOLDER TYPE _____ **2520** _____

SPEC. NO. (P/N) _____ HH26000058 _____

CUSTOMER P/N _____

ISSUE DATE _____ Mar.25,2024 _____

APPROVED	PREPARED	QA
		
APPROVED BY CUSTOMER:		AVL Status
<p>Please return one copy with approval toHLC</p>		

浙江省金华市经济开发区工业园区秋涛北街399
 號
 No.399 Qiutao North Str.,Industrial Area,Economic
 Development Zone,Jinhua,Zhejiang,China
 TEL: 0086-579-82273331
 FAX: 0086-579-82273198



ISO9001
ISO14001



RoHS Compliant (Pb- Free)



TYPE HH SEAM SEALED X'TAL

ELECTRICAL SPECIFICATIONS

HLC Parts Number : HH26000058

Item	Symbol	Specifications				Notes
		Min	Type	Max	Units	
Nominal frequency	FO	26.000000			MHz	
Mode of Oscillation	OT	Fundamental				
Load Capacitance	CL	10			pF	
Frequency Tolerance	FT	± 10			ppm	at 25°C ± 3°C
Frequency Stability		± 30			ppm	with working temperature Reference to 25°C frequency
Working temperature range	TR	-40~85			°C	
Drive Level	DL	100			μW	
Series Resonant Resistance RR	CI/RR	60			Ω	Max.
Insulation Resistance	IR	>500			MΩ	
Shunt Capacitance C0	C0	3			pF	Max.
Aging		± 3			ppm/yr.	
Storage temperature range		-55 ~ 125			°C	

Circuit : Measured by SAUNDERS & ASSOCIATES 250B-1
NETWORK ANALYZER

Insulation Resistance : More Than 500 MΩ at DC 100V

Hermetically (1)Fine Leak : Helium Bombing 4kg/cm² for 1 Hours

(2)Gross Leak : Leak Rate Less Than 1*10⁻⁹ Pa. m³/sec

By Heliot 701W1 M/C

Zhejiang Huilong Crystals Technology Co.,Ltd



TYPE HH SEAM SEALED X'TAL

RELIABILITY SPECIFICATIONS

NO.	TEST ITEM	TEST METHODS
1	DROP TEST	Device are dropped from a height of 75 cm onto 2 mm thickness stainless plate executing 3 times of random drops.
2	MECHANICAL SHOCK	Device are shocked to half sine wave (1000 G) three mutually perpendicular axes each 3 times.
3	VIBRATION	Frequency range 10 ~ 2000 Hz Amplitude 1.5 mm Sweep Time 20 minute Test Time 2 hours
4	SOLDERABILITY	MIL - STD - 20E Method 208C Temperature 245°C±5°C Material H63A (Silver 2 ~ 3 %) Immersion depth 0.5 mm minimum Immersion time 3 ± 0.5 seconds Flux Rosin resin methyl alcohol solvent (1 : 4)
5	RESISTANCE TO SOLDERING HEAT	MIL - SLD -202, Method 210, Condition I or J 10 sec immersion into 260 ± 5°C solder pot, above 180°C is 90 ~ 120 sec.
6	LOW TEMP. STORAGE	Leave at - 40 °C ± 2°C for 16 hours
7	HIGH TEMP. STORAGE	Leave at 125 °C ± 3°C for 72 hours
8	THERMAL SHOCK	Total 100 cycles of the following temperature cycle

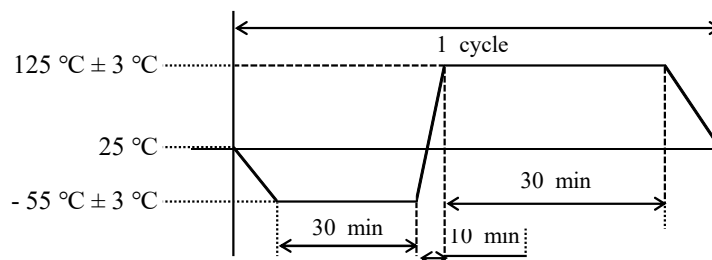

Zhejiang Huilong Crystals Technology Co.,Ltd



TYPE HH SEAM SEALED X'TAL

HLC
* 26.03x

HLC: HLC Use Code x: CL Code

x: Date Code

CL	Code	CL	Code	CL	Code
0pf	0	7.5pf	H	11.2pf	a
6pf	1	11pf	I	11.4pf	b
8pf	2	8.5pf	J	13.5pf	d
10pf	3	7.1pf	K	20.5pf	e
12pf	5	19pf	L	8.8pf	f
15pf	6	12.5pf	M	17pf	g
16pf	7	27pf	N	4.3pf	h
18pf	8	7.3pf	O	9.9pf	i
20pf	9	13pf	P	24pf	j
22pf	A	11.5pf	Q	9.4pf	m
25pf	B	7pf	R	8.2pf	n
28pf	C	14pf	S	6.8pf	q
30pf	D	23pf	T	90pf	r
32pf	E	11.1pf	U	5.6pf	t
9.5pf	F	33pf	V		
9pf	G	10.5pf	W		
		9.2pf	Y		
		50pf	Z		

Jan-23	N	Jan-24	A
Feb-23	P	Feb-24	B
Mar-23	Q	Mar-24	C
Apr-23	R	Apr-24	D
May-23	S	May-24	E
Jun-23	T	Jun-24	F
Jul-23	U	Jul-24	G
Aug-23	V	Aug-24	H
Sep-23	W	Sep-24	J
Oct-23	X	Oct-24	K
Nov-23	Y	Nov-24	L
Dec-23	Z	Dec-24	M

备注：年份印字代码原则按奇偶年两年一个循环

DIMENSIONS

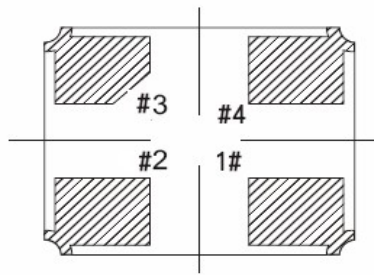
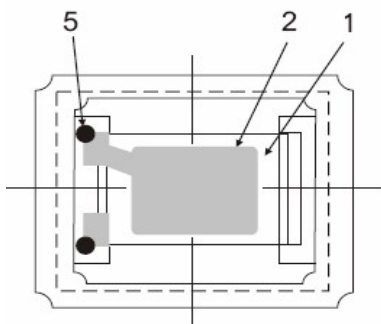
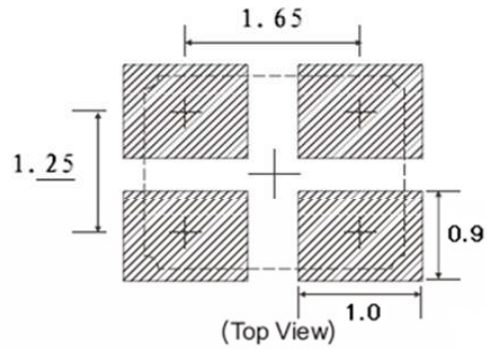
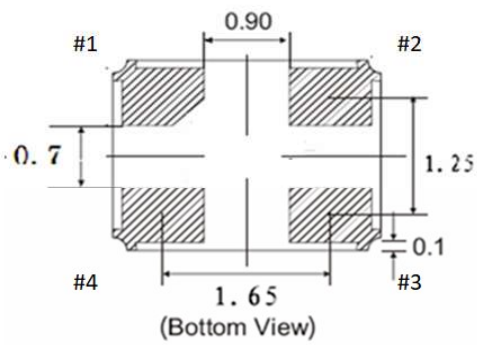
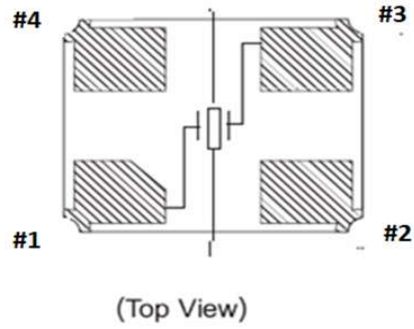
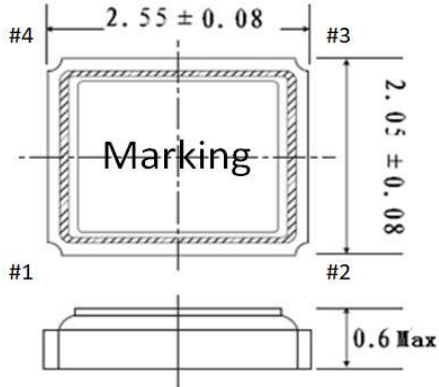

1	Quartz Blank
2	Electrode
3	Lid
4	Base
5	Conductive adhesive

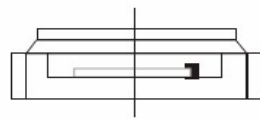
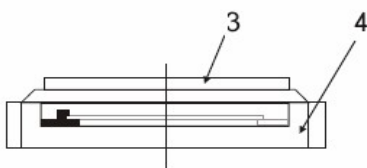

SUGGESTED IR REFLOW PROFILE

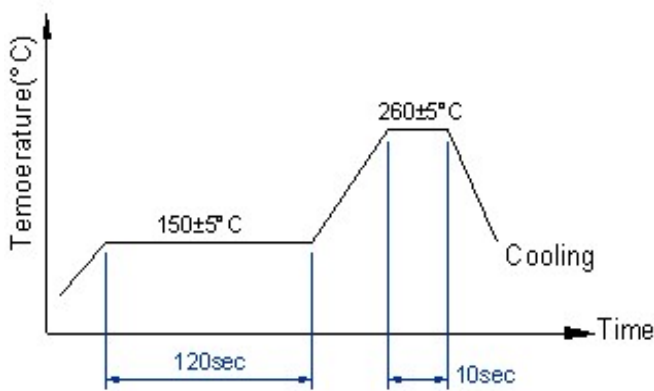

Total Time: 200 Sec.Max
Solder melting point : 185°C

PACKING

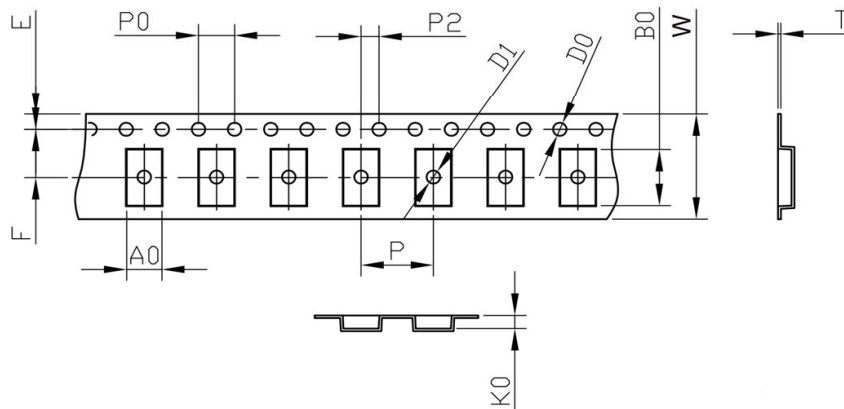

	W	A ₀	B ₀	K ₀	E	F	P	P ₀	P ₂	D ₀	D ₁	T
2520	8.0±0.3	2.25±0.1	2.70±0.1	0.80±0.1	1.75±0.1	3.5±0.1	4.0±0.1	4.0±0.1	2.0±0.1	1.55±0.05	1.0±0.1	0.25±0.05

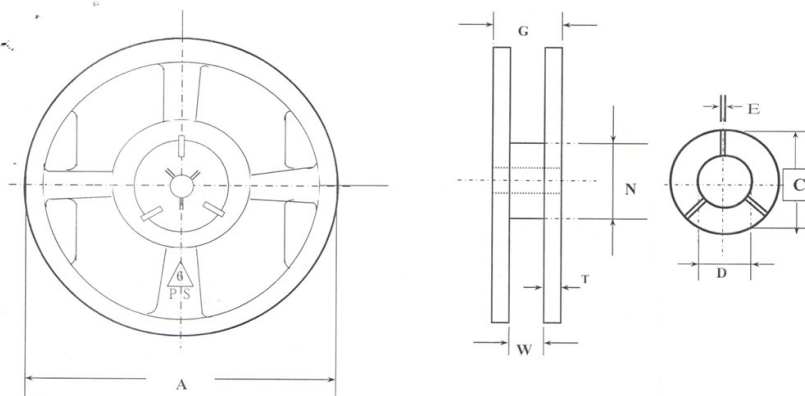

	A	W	T	N	C	D	E	G
2520	178±2.0	9.5±0.5	1.4±0.2	60.2±0.5	20.2±1.0	13.2±0.5	2.5±0.5	12±1.4

- 230mm minimum leader which consist of carrier and/or tape followed by a minimum of 160mm of empty carrier tape sealed with cover tape.
- 160mm minimum trailer of empty carrier tape sealed with cover tape.



TYPE HH SEAM SEALED X'TAL

PACKING

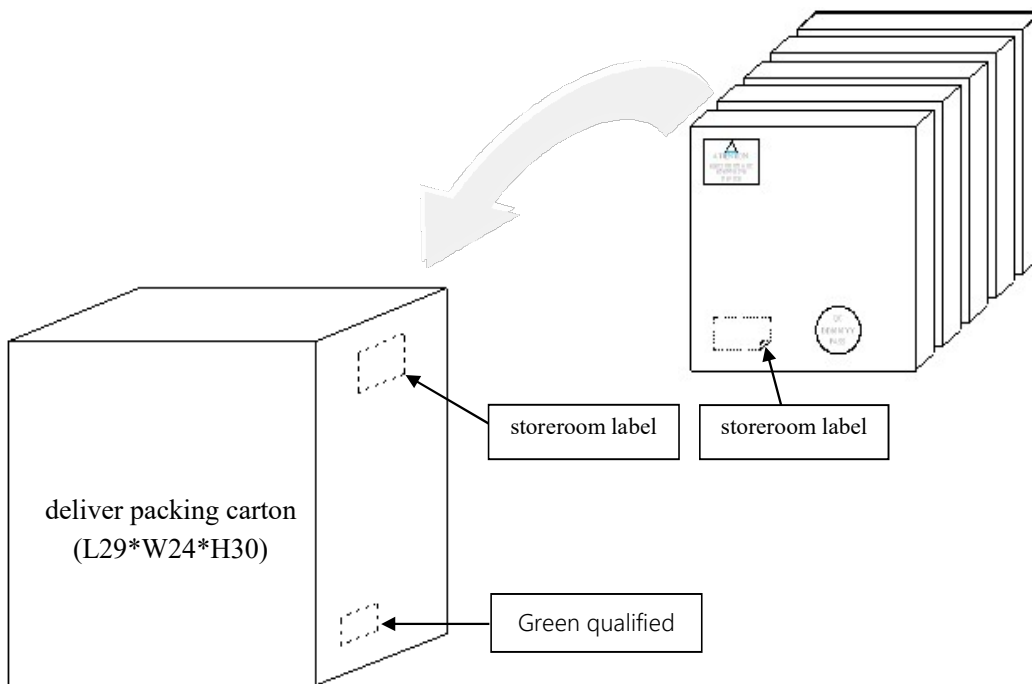
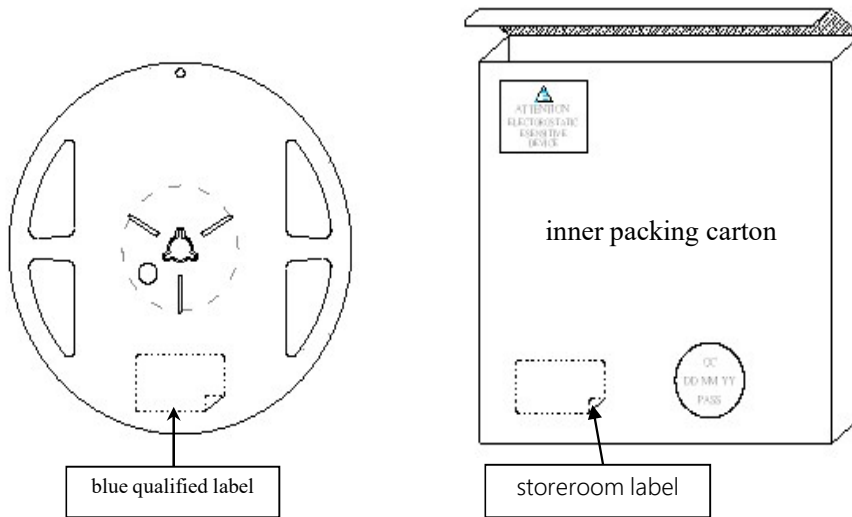
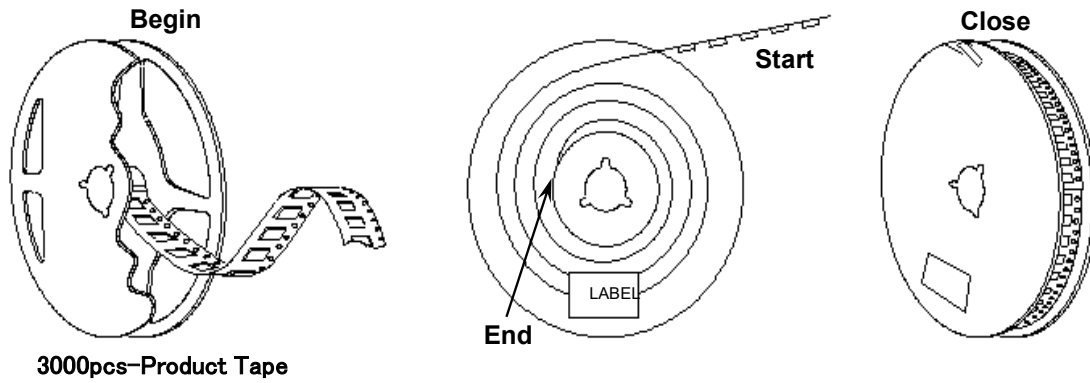

Zhejiang Huilong Crystals Technology Co.,Ltd