

SPECIFICATION

Electret Condenser Microphone

RoHS & REACH

Product : Omni directional ECM Φ 4mmx1.5mm

GETTOP P/N: BOM4015BL- J393AC

Version : V4.0

Designed by	Checked by	Approved by	Released Date
Frank Liu	Jack Liu	Jessica Sun	07-31-2025

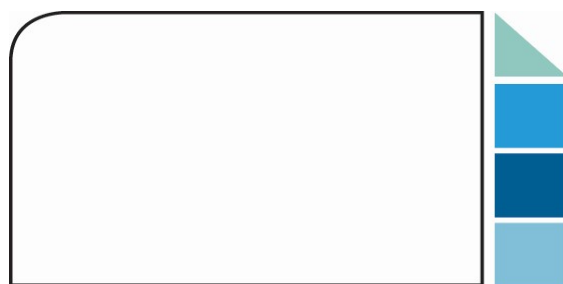

CUSTOMER APPROVAL

Gettop 公司销售/技术支持联系方式 (Http://www.gettopacoustic.com)

Gettop Acoustic Co.,Ltd. Tel: +86 536 2283666 E-Mail: gettop@gettopacoustic.com E-Mail: sales@gettopacoustic.com Website: Http://www.gettopacoustic.com Address: NO.68 Fengshan Road.,Fangzi Development Zone, Weifang,Shandong,China	共达电声股份有限公司 电话: +86 536 2283666 邮箱: gettop@gettopacoustic.com sales@gettopacoustic.com 网址: Http://www.gettopacoustic.com 地址: 中国山东省潍坊市坊子区凤山路 68 号
---	--

Revision History

Date	Version	Description	Controller
02-18-2024	V3.0	Initial Release	Qihua Guo
07-03-2025	V3.1	Updated the FR	Bosco Xie
07-31-2025	V4.0	Added company contact information	Frank Liu

Contents

1. Scope	3
2. Product Type	3
3. Electro-acoustic Specifications	3
4. Typical Frequency Response	4
5. Schematic Diagram	4
6. Measurement System Setup	5
7. Mechanical Specification	5
8. Reliability Tests	6
8.1 Hi-Temperature Test.....	6
8.2 Low-Temperature Test	6
8.3 Humidity & Heat Test	6
8.4 Thermal Shocking Test.....	6
8.5 Vibration Test	6
8.6 Drop Test.....	6
8.7 Soldering Heat Test.....	6
8.8 ESD	7
9. Packaging	7
10. Usage Suggestions	8
10.1 Soldering Suggestions	8
10.2 Others	8
11. Special Cautions	8
11.1 Environmental Condition	8
11.2 Storage.....	8
12. Discard Suggestions	8

1. Scope

This document is the technical specification of electret condenser (ECM) Omni-Directional Microphone.

2. Product Type

BOM4015BL- J393AC

3. Electro-acoustic Specifications

Table 3-1 Electrical Specifications

(Test Condition: +23°C ± 2,63%~67% RH, 86~106Kpa, Vs=2V, unless specified differently)

No.	Parameter	Symbol	Condition	Limits			Unit
				Min	Nom.	Max	
3.1	Sensitivity	S	f=1kHz, Pin=1Pa, 0dB=1V/Pa	-42	-39	-36	dB
3.2	Directivity			Omni-directional			
3.3	Output Impedance	ZOUT	f=1kHz			2.2	kΩ
3.4	Current Consumption	IDSS	RL=2.2kΩ, Vs=3.0V			500	μA
3.5	S/N Ratio	S/N	f=1kHz, Pin=1Pa, (A-Weighted)		67		dB
3.6	Operating Voltage	Vmic		1.0		5	V
3.7	Sensitivity vs. Voltage	ΔS	Vs= 3.0V to 1.5V			3	dB
3.8	Total Harmonic Distortion	THD	94dB SPL at 200Hz~8kHz			1	%
			115dB SPL at 1kHz			3	%
3.9	Acoustic Overload Point	AOP	THD 10%@1KHz		128		dB SPL

Note: Considering tester and testing difference between each other, sensitivity 0.5 dB out of specification will be acceptable by customer for an acceptance.

4. Typical Frequency Response

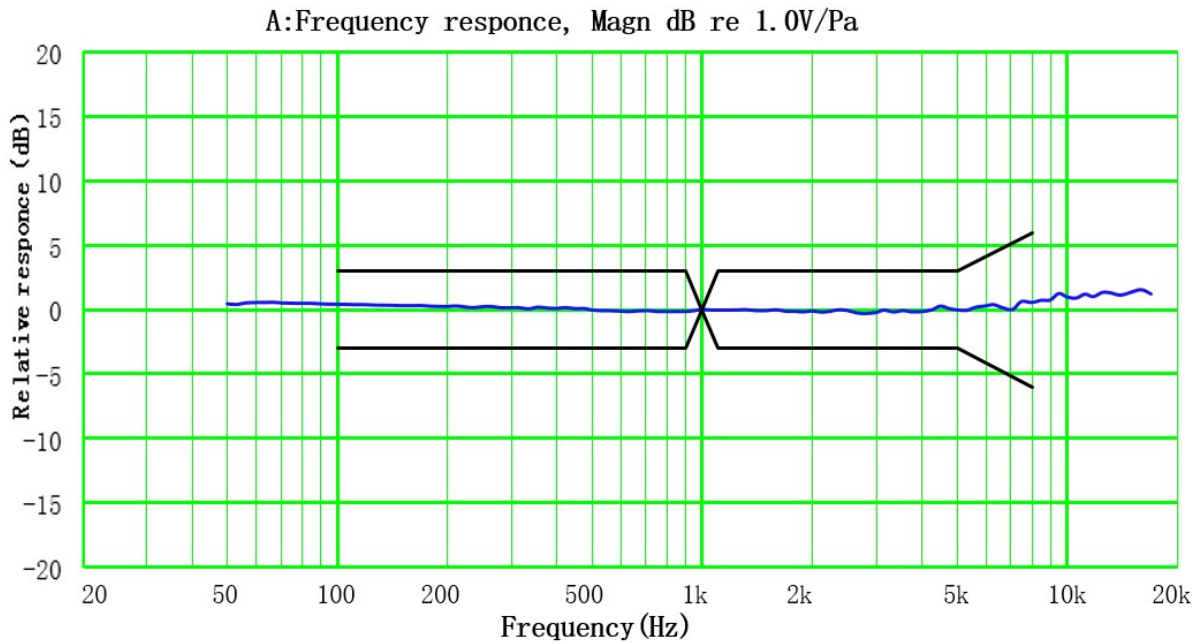

Fig. 4-1 Typical Frequency Response

Table 4-1 Frequency Response Limit Template

Frequency [Hz]	100	200	900	1K	1.1K	3K	5K	8K
Upper limit [dB]	3	3	3	0	3	3	3	6
Frequency [Hz]	100	200	900	1K	1.1K	3K	5K	8K
Lower limit [dB]	-3	-3	-3	0	-3	-3	-3	-6

5. Schematic Diagram

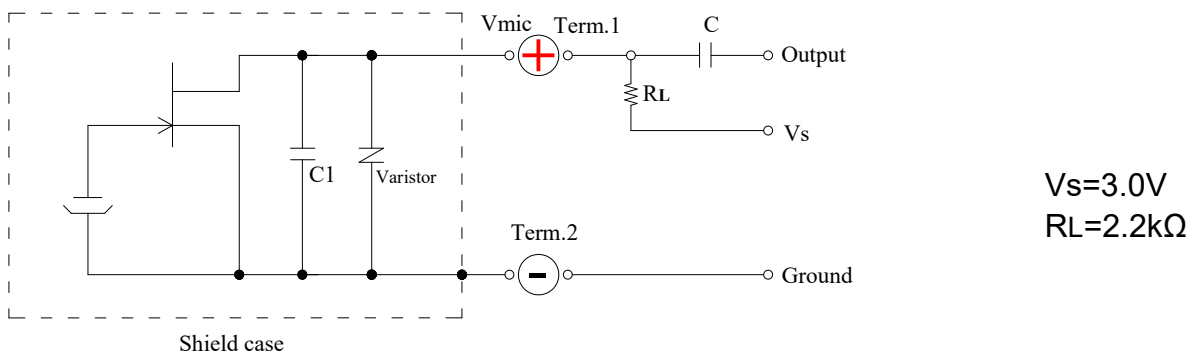

Fig. 5-1 Schematic Diagram

6. Measurement System Setup

Test signal: Sinusoid, Sweep,

Frequency Range: 50Hz-17KHz

Step: 1/12 octave

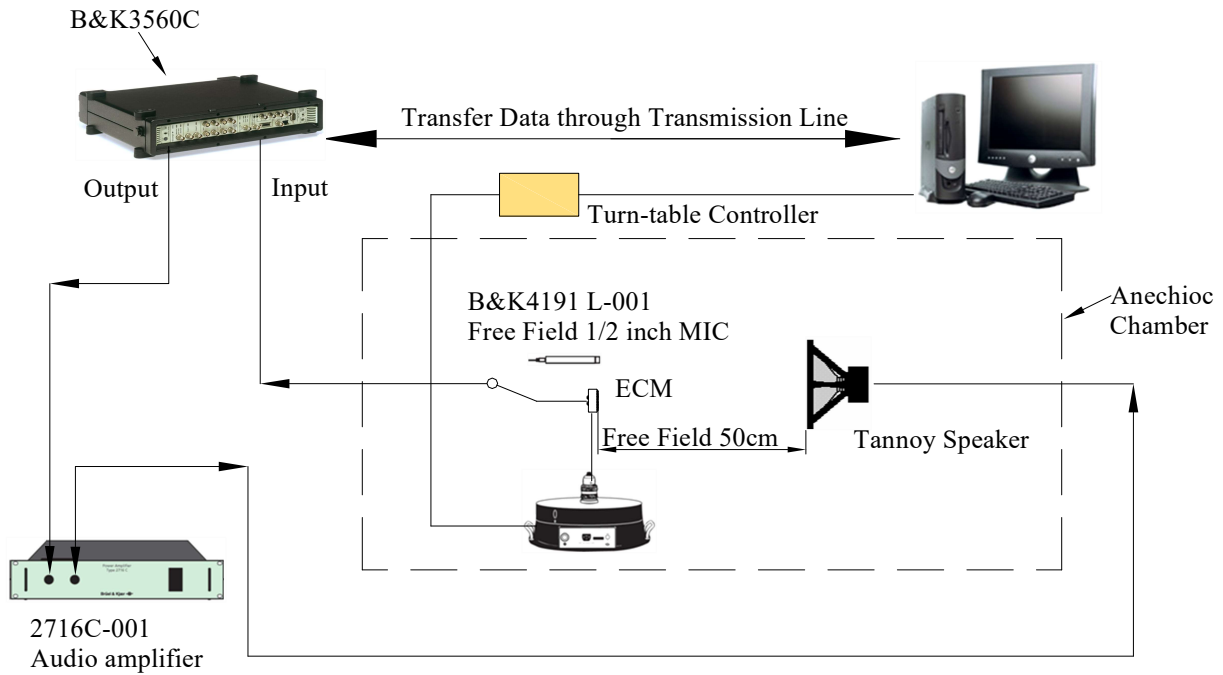
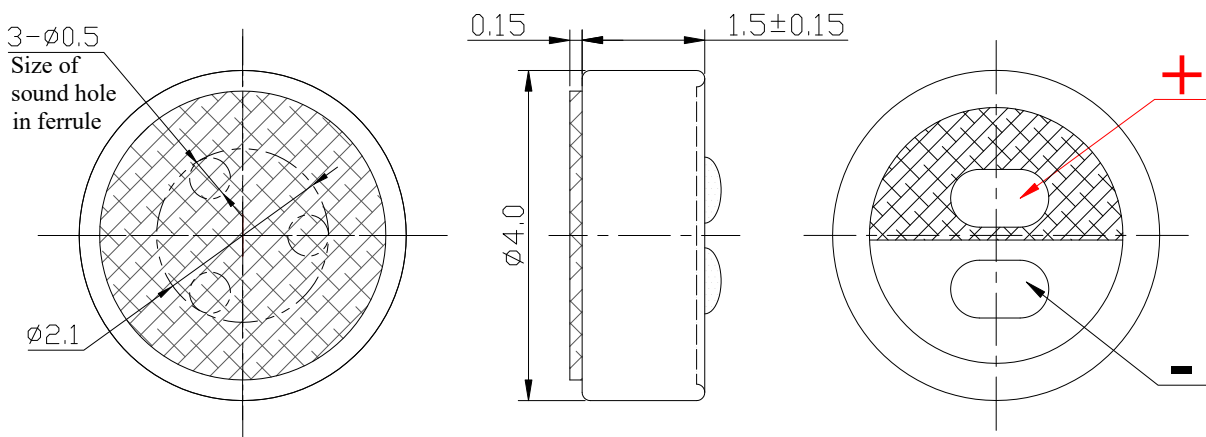

Fig. 6-1 Measurement System Setup

7. Mechanical Specification



Unmarked Tolerance: ± 0.1 (mm)

Fig. 7-1 Microphone capsule

8. Reliability Tests

After conducting any of the following tests, the sensitivity change of DUT shall be less than $\pm 3\text{dB}$ from its initial value and shall keep its initial operation and appearance.

The measurement to be done after 2 hours of conditioning at $+15\text{ }^{\circ}\text{C} \sim +35\text{ }^{\circ}\text{C}$, R.H 45%~75%.

8.1 Hi-Temperature Test

Temperature: $+85\text{ }^{\circ}\text{C}$
Duration: 240 hours

8.2 Low-Temperature Test

Temperature: $-40\text{ }^{\circ}\text{C}$
Duration: 240 hours

8.3 Humidity & Heat Test

Temperature: $+60\text{ }^{\circ}\text{C}$
Humidity: 93% RH
Duration: 240 hours

8.4 Thermal Shocking Test

Temperature & duration: $-40\text{ }^{\circ}\text{C}$, 30 minutes
Temperature & duration: $+80\text{ }^{\circ}\text{C}$, 30 minutes,
Cycles: 32 cycles

8.5 Vibration Test

Frequency: 10-55Hz
Amplitude: 1.52mm
Direction: 2 directions
Duration: 2 hours

8.6 Drop Test

Drop the microphones to the floor
Height: 1.5m
Reference surface: slippery marble floor
Duration: 3 times

8.7 Soldering Heat Test

Place microphones in the metallic fixture.
Soldering Heat: $350\text{ }^{\circ}\text{C}$
Duration: 5S
Recover: 1h

8.8 ESD

The tests are performed acc. to IEC61000-4-2 level 4

a. Contact discharge

Discharge position: Output of microphone

Charge voltage: $\pm 8000\text{VDC}$

Discharge network: $150\text{pF} \ \& \ 330\Omega$

b. Air discharge

Discharge position: Sound hole

Charge voltage: $\pm 15000\text{VDC}$

Discharge network: $150\text{pF} \ \& \ 330\Omega$

9. Packaging

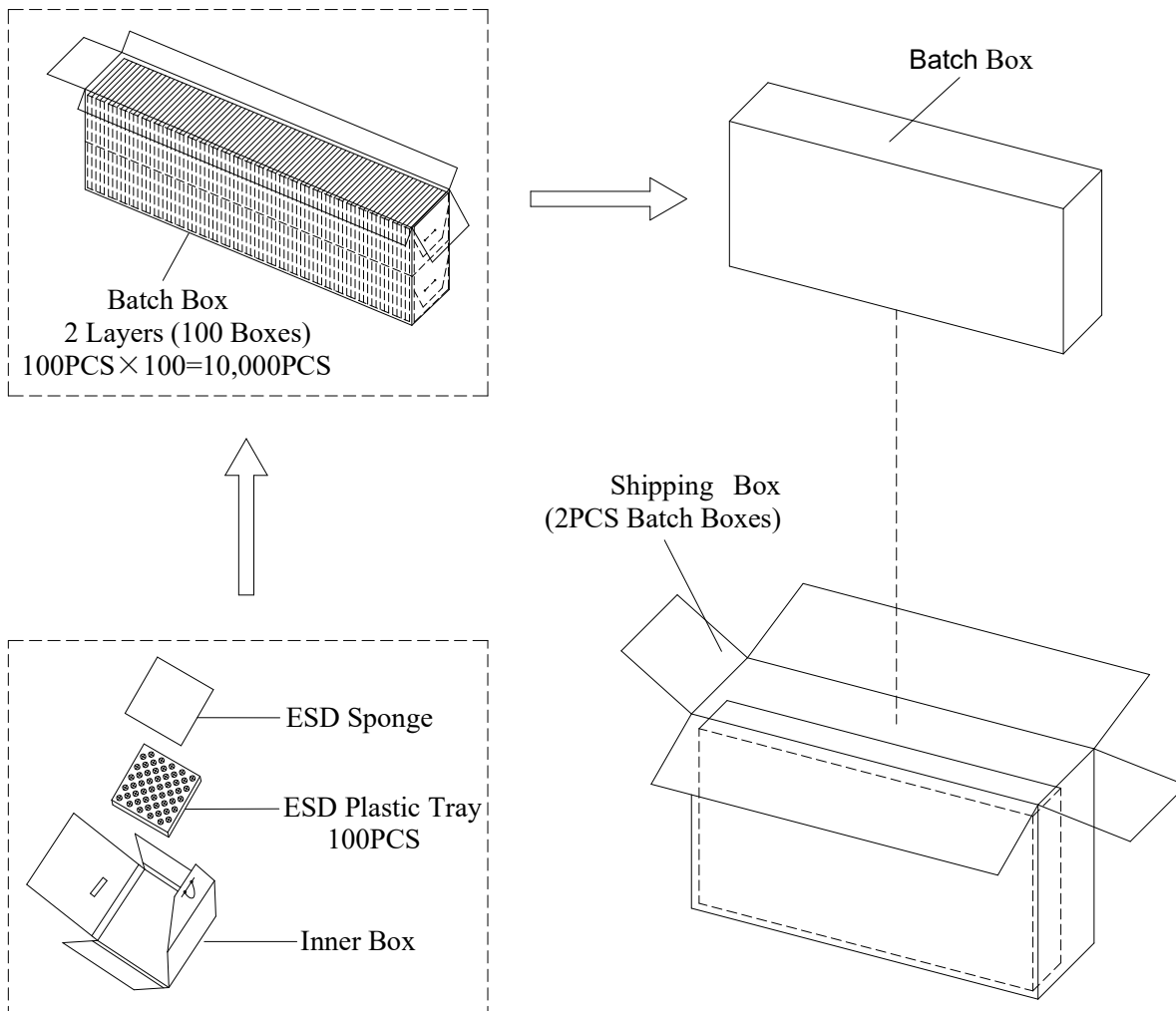

Inner Box	100mm×100mm×6mm	100PCS×1=100PCS
Batch Box	435mm×115mm×275mm	100PCS×100=10,000PCS
Shipping Box	455mm×270mm×295mm	10,000PCS×2=20,000PCS

10. Usage Suggestions

10.1 Soldering Suggestions

All the soldering process should be completed in a metallic fixture. Based on a 90-watt soldering iron, the temperature of the soldering iron suggest be limited to $340^{\circ}\text{C} \pm 10^{\circ}\text{C}$. Soldering time on each pad should not exceed 1 second. If other welding method is used, to evaluate its influence on microphone is necessary.

Operators, the solder fixture and the soldering iron must be statically grounded under each soldering process.

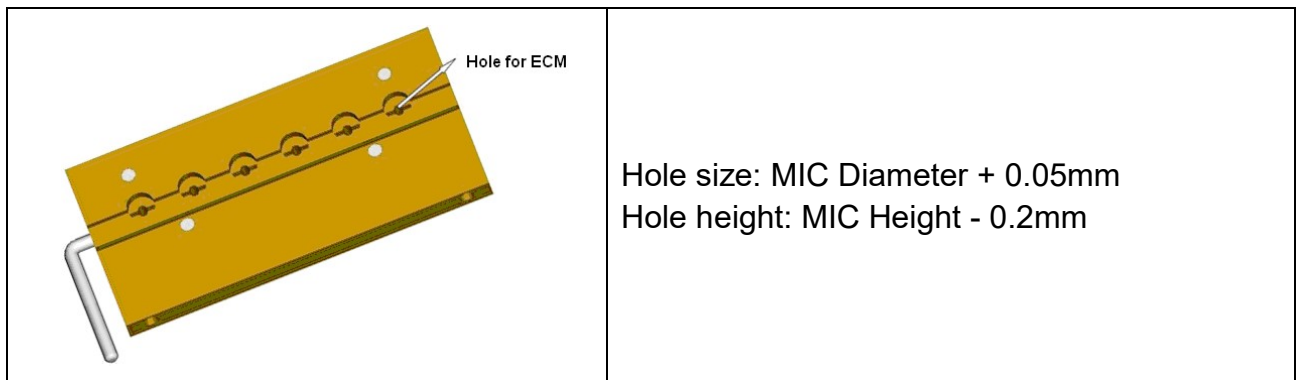

Fig. 10-1 Soldering Fixture

10.2 Others

Avoid volatilization of harmful substance that affects the performances of microphone, such as volatile glue and so on.

11. Special Cautions

11.1 Environmental Condition

Storage Condition: $-40^{\circ}\text{C} \sim +70^{\circ}\text{C}$.

Operation Condition: $-20^{\circ}\text{C} \sim +60^{\circ}\text{C}$.

Arbitration Condition: $23^{\circ}\text{C} \pm 1^{\circ}\text{C}$, R.H. 63%~67%, Air pressure: 86~106Kpa.

11.2 Storage

Keep ECM in warehouse with humidity less than 75%R.H. and without sudden temperature change, acid air, any other harmful air or strong magnetic field.

Please protect products against moist, shock, sunburn and pressure.

Please take proper measures against ESD in the process. Please use the shipment package for long-term storage.

12. Discard Suggestions

For microphones to be wasted, customer shall follow the regulation of Waste Electrical and Electronic Equipment (WEEE) Directive (2002/96/EC).