

## FEATURES

- Fast switching
- 100% avalanche tested
- Improved dv/dt capability

## APPLICATIONS

- Switch Mode Power Supply (SMPS)
- Uninterruptible Power Supply (UPS)
- Power Factor Correction (PFC)

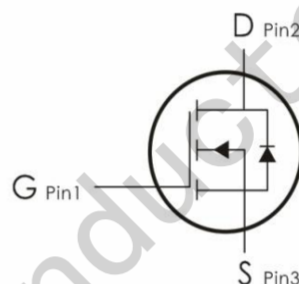
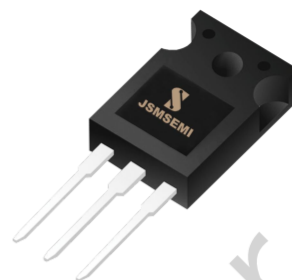

Device Marking and Package Information		
Device	Package	Marking
FQA7N80C	TO-247	FQA7N80C

## Absolute Maximum Ratings (Ta=25°C unless otherwise noted)

Symbol	Parameter	Value	Unit
$V_{DSS}$	Drain-Source Voltage	800	V
$I_D$	Drain Current	$T_j=25^\circ\text{C}$	8.0
		$T_j=100^\circ\text{C}$	5.0
$V_{GSS}$		$\pm 30$	V
$E_{AS}$	Single Pulse Avalanche Energy (note1)	150	mJ
$I_{AR}$	Avalanche Current (note2)	8.0	A
$P_D$	Power Dissipation ( $T_j=25^\circ\text{C}$ )	150	W
$T_j$	Junction Temperature(Max)	150	$^\circ\text{C}$
$T_{stg}$	Storage Temperature	-55~+150	$^\circ\text{C}$
$T_L$	Maximum lead temperature for soldering purpose, 1/8" from case for 5 seconds	300	$^\circ\text{C}$

## Thermal Characteristics

Symbol	Parameter	Typ.	Max.	Unit
$R_{\theta JC}$	Thermal Resistance, Junction to Case	-	2.6	$^\circ\text{C/W}$
$R_{\theta JA}$	Thermal Resistance, Junction to Ambient	-	62.5	$^\circ\text{C/W}$

**Electrical Characteristics** (Ta=25°C unless otherwise noted)

Symbol	Parameter	Test Condition	Min.	Typ.	Max.	Unit
<b>Off Characteristics</b>						
$BV_{DSS}$	Drain-Source Breakdown Voltage	$I_D=250\mu A, V_{GS}=0$	800	-	-	V
$\Delta BVDSS/\Delta T_J$	Breakdown Voltage Temperature Coefficient	$I_D=250\mu A$ , Reference to 25°C	-	0.67	-	V/°C
$I_{DSS}$	Zero Gate Voltage Drain Current	$V_{DS}=800V, V_{GS}=0V$	-	-	10	$\mu A$
		$V_{DS}=640V, T_J=125^\circ C$	-	-	100	
$I_{GSSF}$	Gate-body leakage Current, Forward	$V_{GS}=+30V, V_{DS}=0V$	-	-	100	nA
$I_{GSSR}$	Gate-body leakage Current, Reverse	$V_{GS}=-30V, V_{DS}=0V$	-	-	-100	
<b>On Characteristics</b>						
$V_{GS(TH)}$	Gate Threshold Voltage	$I_D=250\mu A, V_{DS}=V_{GS}$	2	-	4	V
$R_{DS(ON)}$	Static Drain-Source On-Resistance	$I_D=3.5A, V_{GS}=10V$	-	1.5	1.7	$\Omega$
<b>Dynamic Characteristics</b>						
$C_{iss}$	Input Capacitance	$V_{DS}=25V, V_{GS}=0, f=1.0MHz$	-	1550	-	$\mu F$
$C_{oss}$	Output Capacitance		-	135	-	
$C_{rss}$	Reverse Transfer Capacitance		-	12	-	
<b>Switching Characteristics</b>						
$T_d(on)$	Turn-On Delay Time	$V_{DD}=400V, I_D=7A, R_G=12\Omega$	-	15	-	ns
$T_r$	Turn-On Rise Time		-	25	-	
$T_d(off)$	Turn-Off Delay Time		-	51	-	
$T_f$	Turn-Off Rise Time		-	31	-	
$Q_g$	Total Gate Charge	$V_{DS}=400V, V_{GS}=10V, I_D=7A$	-	34	-	nC
$Q_{gs}$	Gate-Source Charge		-	6.0	-	
$Q_{gd}$	Gate-Drain Charge		-	14	-	
<b>Drain-Source Diode Characteristics and Maximum Ratings</b>						
$I_S$	Max. Diode Forward Current	-	-	-	8	A
$I_{SM}$	Max. Pulsed Forward Current	-	-	-	32	
$V_{SD}$	Diode Forward Voltage	$I_D=7A$	-	-	1.5	V
$T_{rr}$	Reverse Recovery Time	$I_S=7A, V_{GS}=0V, diF/dt=100A/\mu s$	-	186	-	nS
$Q_{rr}$	Reverse Recovery Charge	(Note3)	-	878	-	$\mu C$

- Notes : 1, L=25.0mH, IAS=7A, VDD=50V, RG=25 $\Omega$ , Starting T<sub>J</sub> =25°C  
 2, Repetitive Rating : Pulse width limited by maximum junction temperature  
 3, Pulse Test : Pulse Width  $\leq$  300 $\mu s$ , Duty Cycle  $\leq$  2%  
 4, Essentially Independent of Operating Temperature

Typical Characteristics

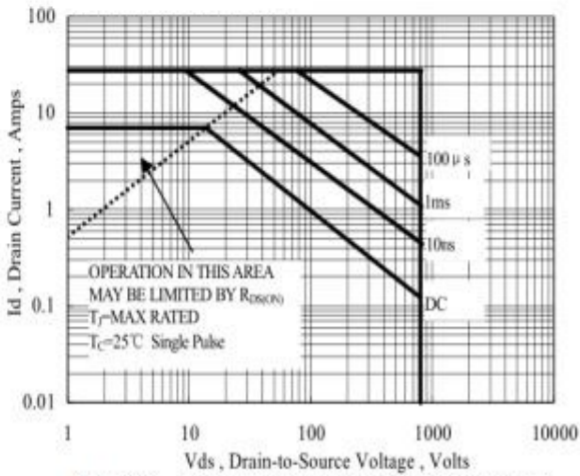

Figure 1a Maximum Forward Bias Safe Operating Area

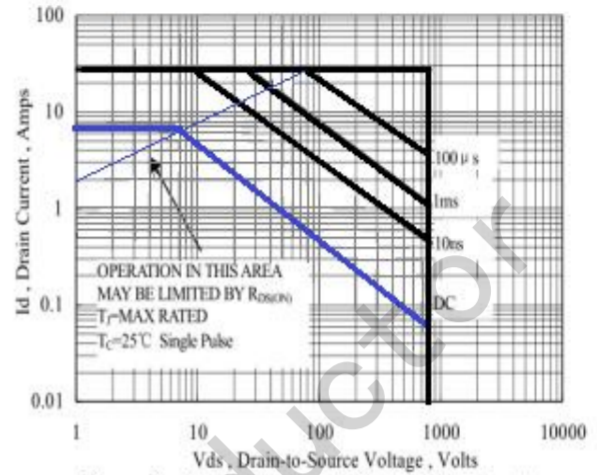

Figure 1b Maximum Forward Bias Safe Operating Area

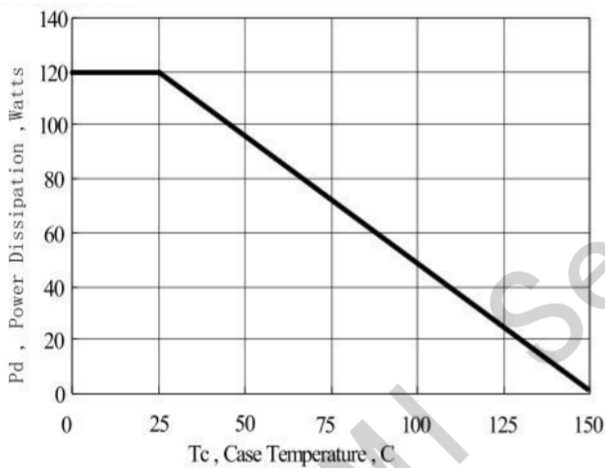

Figure.2(a) Maximum Power Dissipation VS Case Temperature

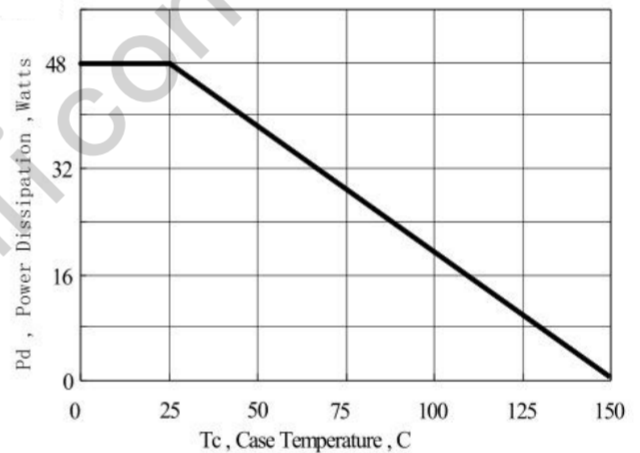

Figure.2(b) Maximum Power Dissipation VS Case Temperature

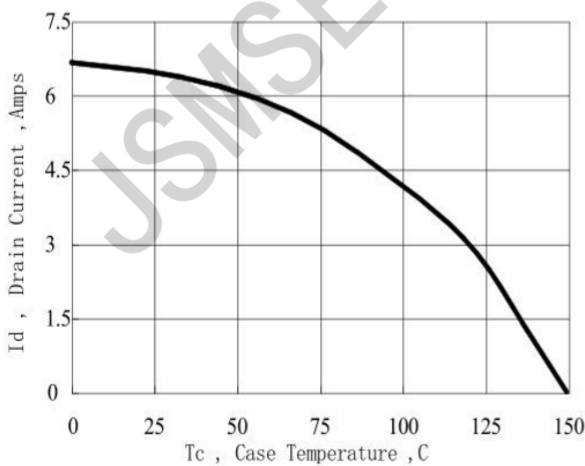

Figure 3 Maximum Continuous Drain Current vs Case Temperature

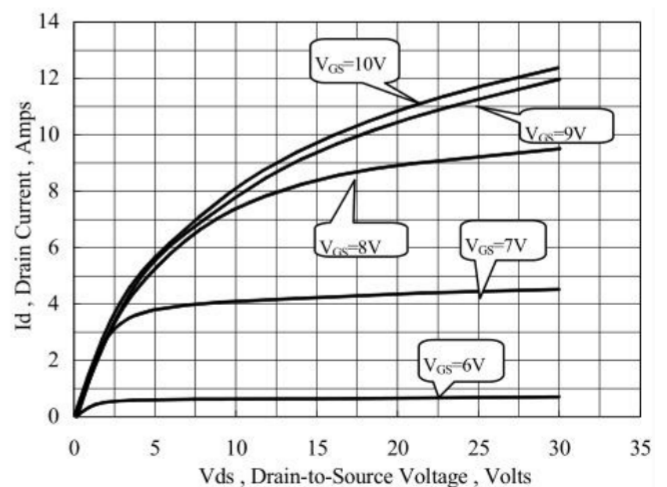

Figure 4 Typical Output Characteristics

Typical Characteristics (Continued)

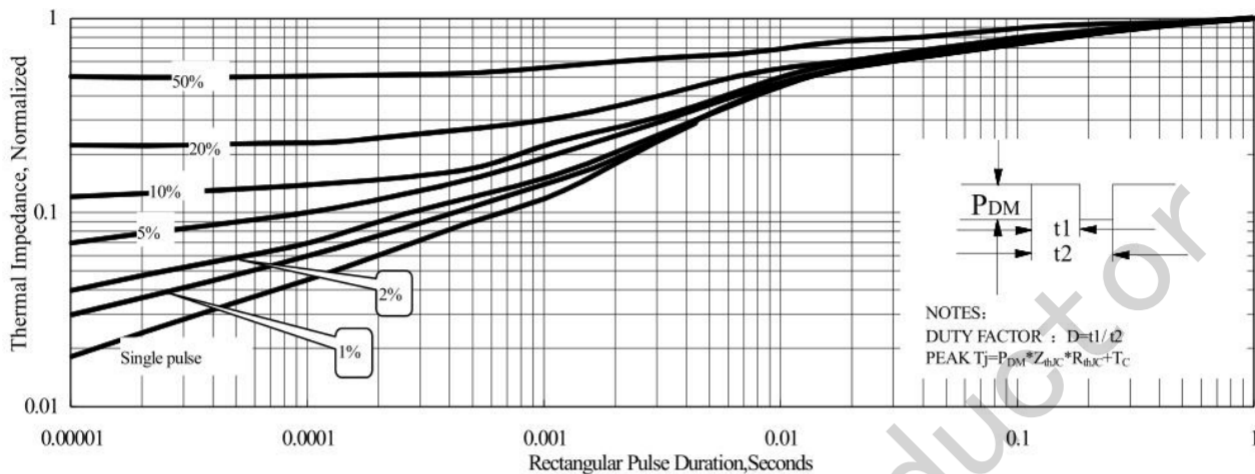

Figure 5 Maximum Effective Thermal Impedance, Junction to Case

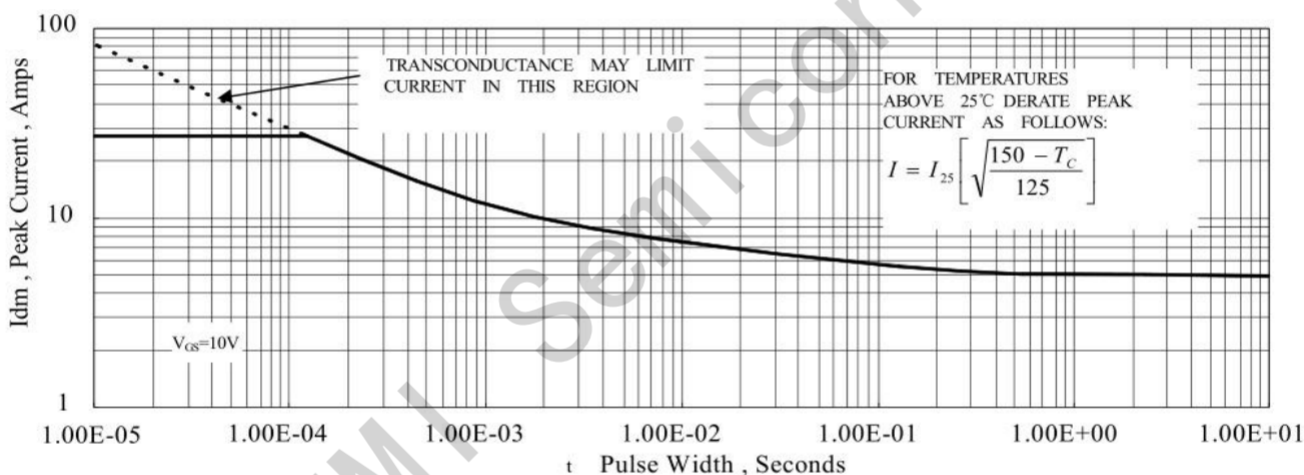

Figure 6 Maximum Peak Current Capability

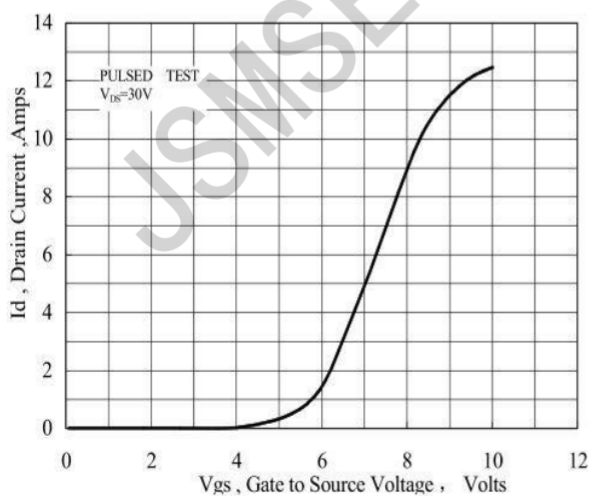

Figure 7 Typical Transfer Characteristics

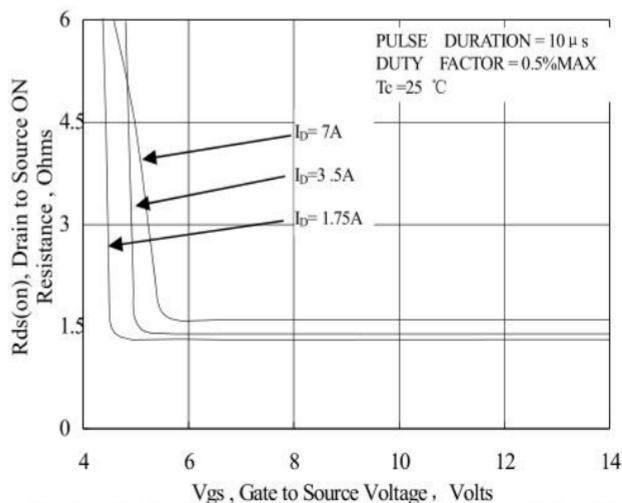
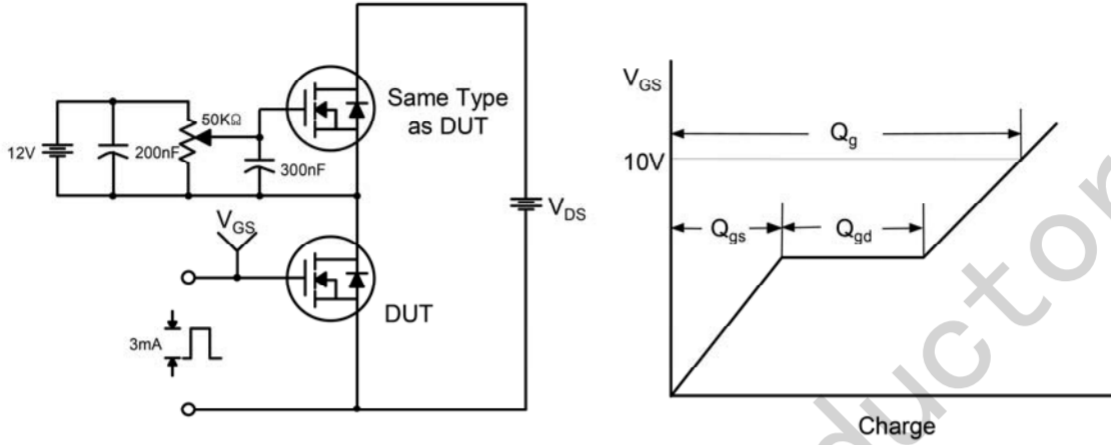
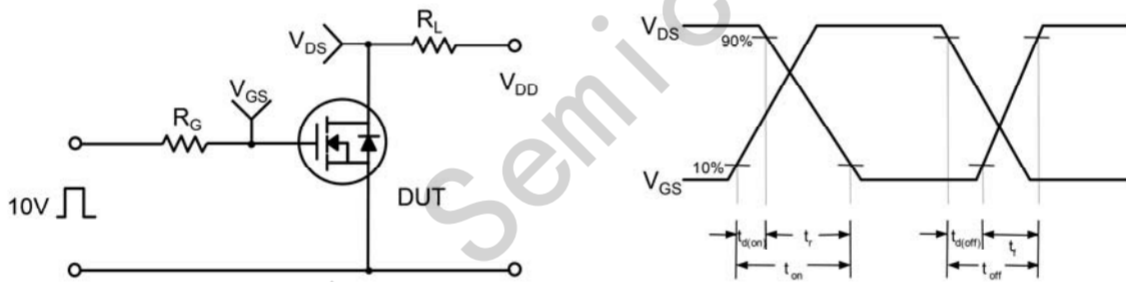

Figure 8 Typical Drain to Source ON Resistance vs Gate Voltage and Drain Current

**Gate Charge Test Circuit & Waveform**



**Resistive Switching Test Circuit & Waveforms**



**Unclamped Inductive Switching Test Circuit & Waveforms**

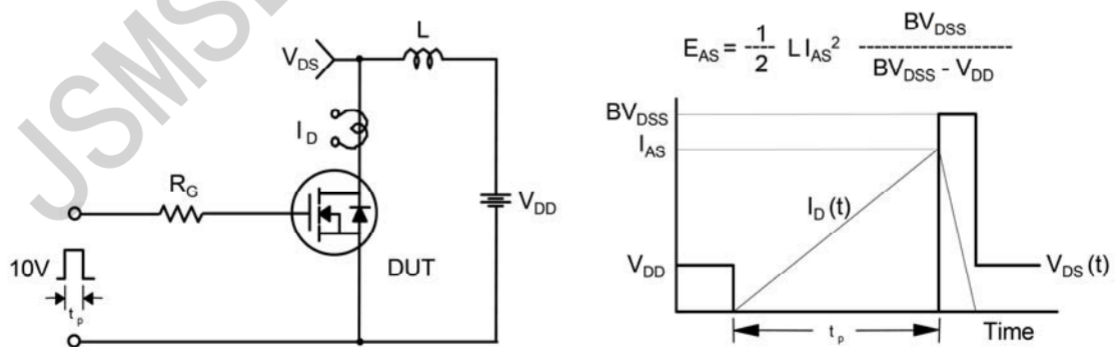

Peak Diode Recovery dv/dt Test Circuit & Waveform

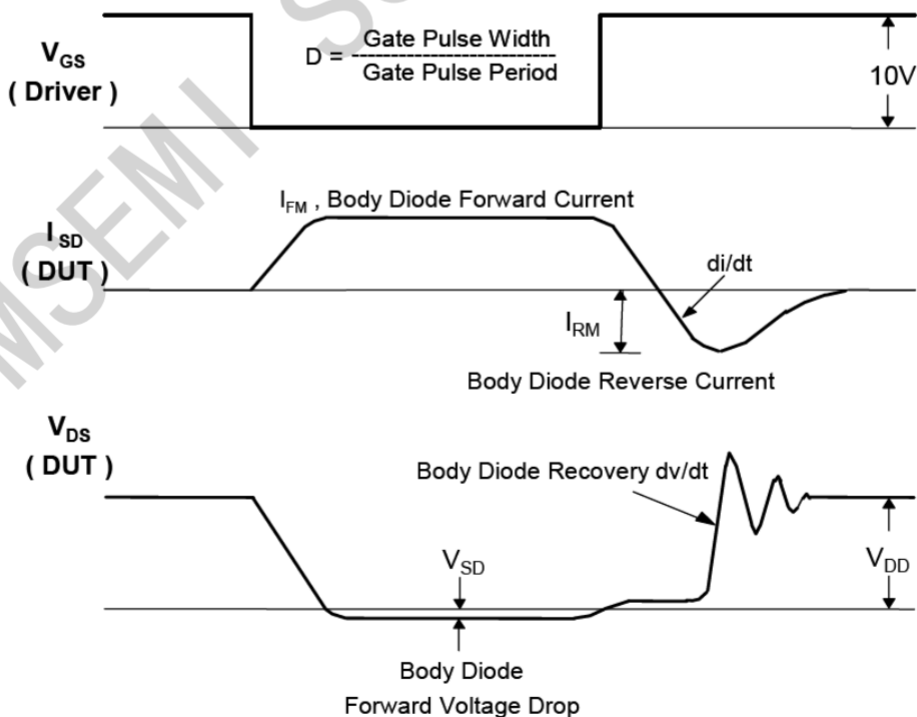
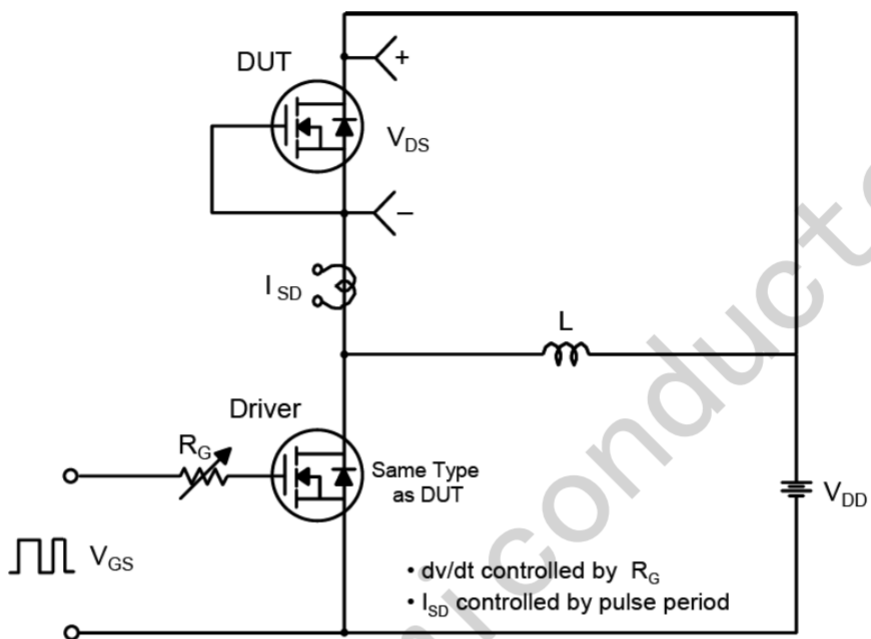

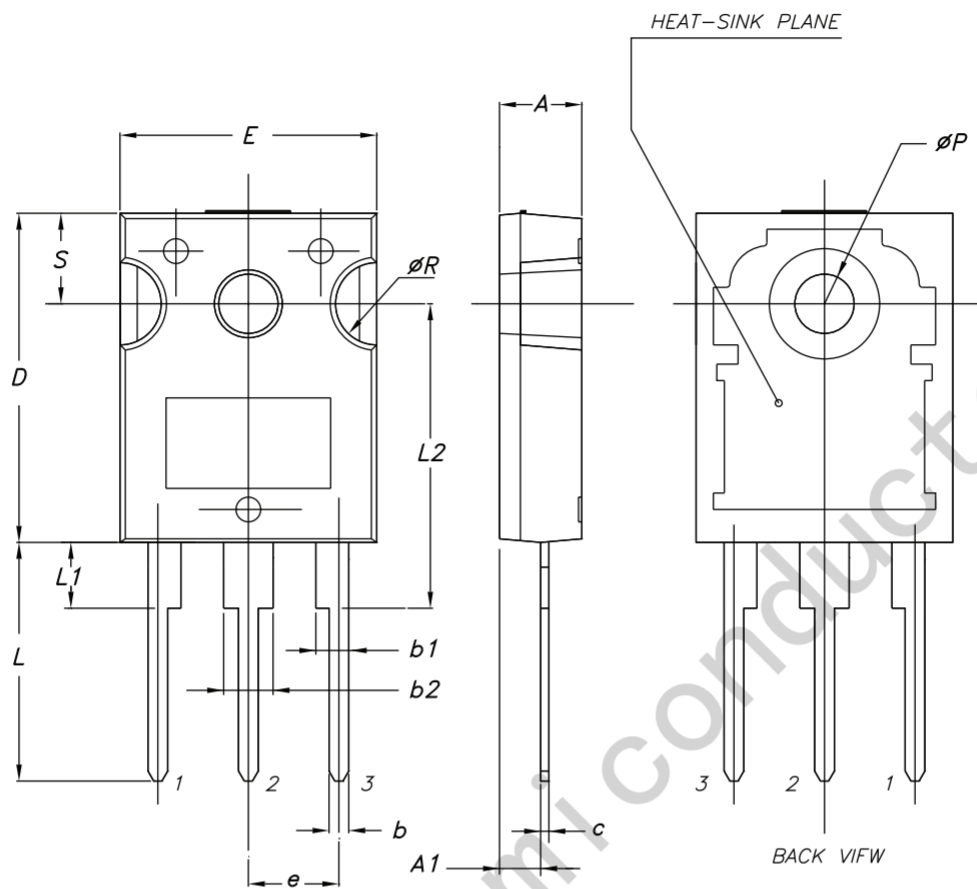

Dim.	mm.		
	Min.	Typ.	Max.
A	4.85		5.15
A1	2.20		2.60
b	1.0		1.40
b1	2.0		2.40
b2	3.0		3.40
c	0.40		0.80
D	19.85		20.15
E	15.45		15.75
e	5.30	5.45	5.60
L	14.20		14.80
L1	3.70		4.30
L2		18.50	
$\phi P$	3.55		3.65
$\phi R$	4.50		5.50
S	5.30	5.50	5.70