



深圳市兴华鑫电子科技有限公司

Shenzhen xinghuaxin Electronic Technology Co., Ltd

承認書

SPECIFICATION FOR APPROVAL

客戶 (Customer): _____
客戶料號 (Customer P/N): _____
興華鑫型號 (Supplier P/N): 20MM-4 Ω 3W
產品名稱 (Description): 喇叭 (Speaker)
產品規格 (Specification): 20*7.5MM 圆形多媒体

客戶承認欄 (Customer Authorization Signature)	深圳市興華鑫電子科技有限公司 承認欄 (Supplier Audit)		
	審核	檢查	制作
	唐国兴	唐玉来	吴银娟
	日期: 2024 年 08 月 17 日		
	版次: A		

声音让生活更精彩!

地址: 深圳市宝安区新安街道新乐社区新乐路 88 号厂房四层

TEL: 0755-27892904

E-mail: jacky.tang@jsxhxdz.com

Http: www.jsxhxdz.com

深圳市兴华鑫电子科技有限公司

Model No.	XHXDZ-20MM 圆形-4R3W	Date	2024-08-17	Page No.	1 / 6
-----------	--------------------	------	------------	----------	-------

產品規格內容 (SPECIFICATION)

1. 使用範圍 (Scope)

此份規格書是針對多媒體產品內，所使用的微型揚聲器單體所提出的報告。

This specification covers our product of miniature speaker unit for multimedia product.

2. 标准测试条件 (Test condition)

一般规格试验状态（特殊要求除外）：常温 5~35℃，常湿 45%~85%，气压 860~1060hPa.

判定上有疑问时，试验状态为：温度 20±2℃，相对湿度 60%~70%，气压 860~1060 hPa.

The test conditions unless otherwise specified should be normal temperature 5 to 35 °C, Normal humidity 45 to 85% and normal atmospheric pressure 860 to 1060 hPa, However, if there arises a doubt in judgment, the test conditions shall be as follows:

Temperature 20±2℃

Humidity 60%~70%

Atmosphere 860~1060 hPa

3. 電聲特性 (ELECTRO-ACOUSTIC CHARACTERISTICS)

3.1 額定阻抗 (Rated Impedance):

4Ω ± 15% (At 1.6K Hz, 1.0 Vrms)

3.2 額定輸入功率 (Rated Input Power)

3 Watt (At 3.46 Vrms white noise 96 Hours)

3.3 最大輸入功率 (Max. Input Power)

3.2 Watt

3.4 最低共振頻率 (Resonant Frequency)

580 Hz ± 20%

3.5 輸出音壓 (Output S.P.L)

89 ± 3dB (1.0 Watt, 0.1 Meter. Average at 1.5K, 2.0K, 2.5K, 3.0K Hz)

3.6 實效頻率範圍 (Frequency Range)

Fo ~ 20KHz (By Output S.P.L. -10dB)

3.7 失真率 (Distortion)

Less than 5% (At 1.6KHz, 2.0 Vrms)

3.8 工作溫度 (Operating Temperature)

-25℃ ~ +50℃

3.9 儲存溫度 (Storage temperature)

-25℃ ~ +55℃

制 定

审 核

核 准

文 件 编 号

黄立强

唐海兵

唐国兴

產品規格內容 (SPECIFICATION)

Model No.	XHXDZ-20MM 圓形-4R3W	Date	2024-08-17	Page No.	2 / 6
------------------	---------------------------	-------------	------------	-----------------	-------

4. 可靠性測試 (Reliability Test)

4.1 高低溫差循環測試(Temperature Cycling Test)

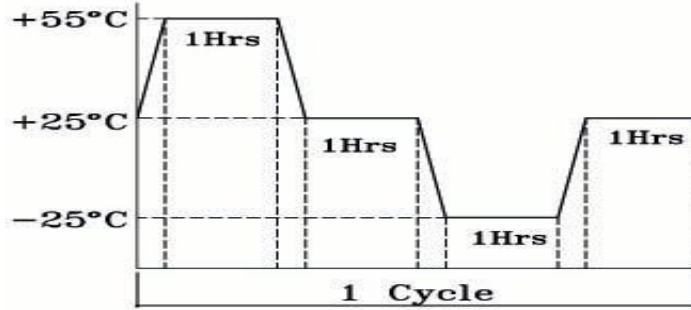

A	Low Temperature (-25°C±3°C)
B	High Temperature (+55°C±3°C)
C	Number of Cycle (3 Cycles)
D	Duration of Exposure 1 Hours, at Each Temperature Extremes
E	Duration of Recovery 1 Hours

4.2 抗濕度試驗(Humidity Test)

A	相對濕度(Relative Humidity)	90-95% at + 40°C ± 3°C
B	測試時間(Durations)	96 Hours
C	恢覆時間(Durations of recovery)	6 Hours

4.3 連續負載測試(Load Test)

White Noise Without Weighted Filter 3.46 Volts.(RMS) 96 Hrs.

4.4 跌落試驗(Drop Test)

75 cm Free Falling On Concrete Floor, 10 Times.

4.5 異常音測試(Buzzes & Rattles)

Sine wave between at 3.46Vrms / 50~5000Hz

4.6 極性測試(Polarity test)

Diaphragm Shall Move Forward When Apply a Positive DC. Current to the “+” or “Marked” Terminal.

產品規格內容 (SPECIFICATION)

Model No.	XHXDZ-20MM 圓形-4R3W	Date	2024-08-17	Page No.	3 / 6
-----------	--------------------	------	------------	----------	-------

5.測量方式 (Measurement Method)

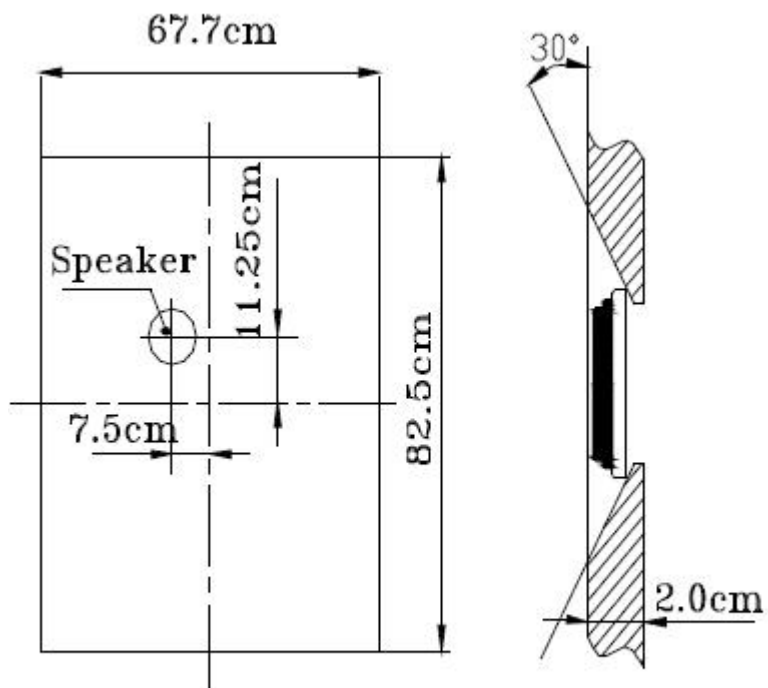
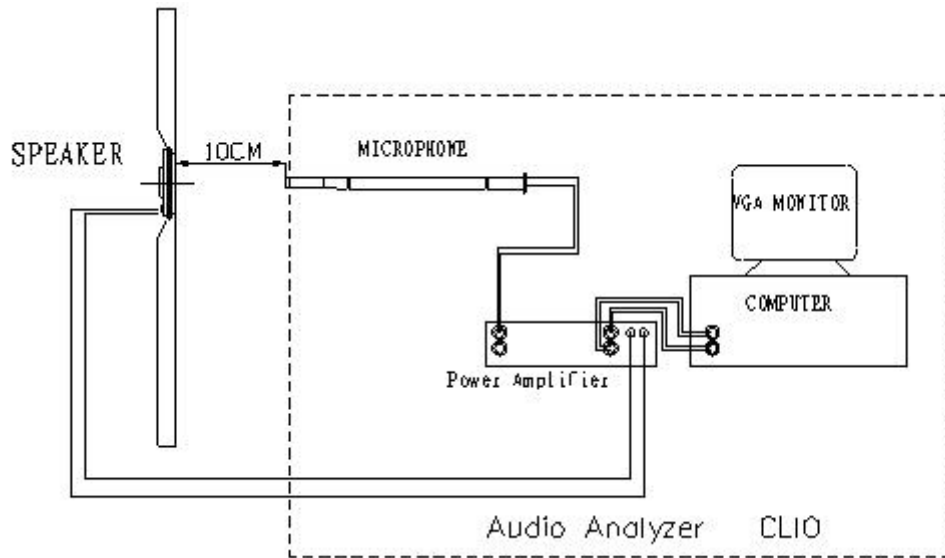

產品規格內容 (SPECIFICATION)

Model No.	XHXDZ-20MM 圓形-4R3W	Date	2024-08-17	Page No.	4/6
-----------	--------------------	------	------------	----------	-----

6. 頻率響應曲線圖(Frequency Response Curve)

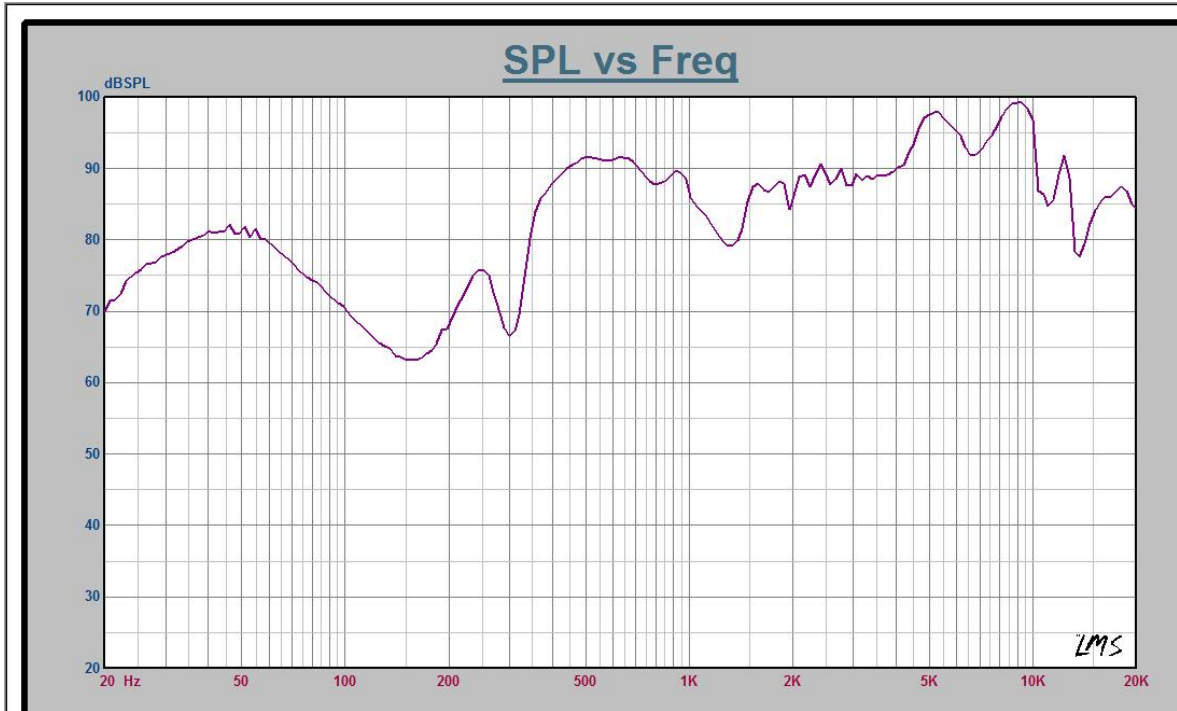

7. 阻抗曲線圖(Impedance Curve)

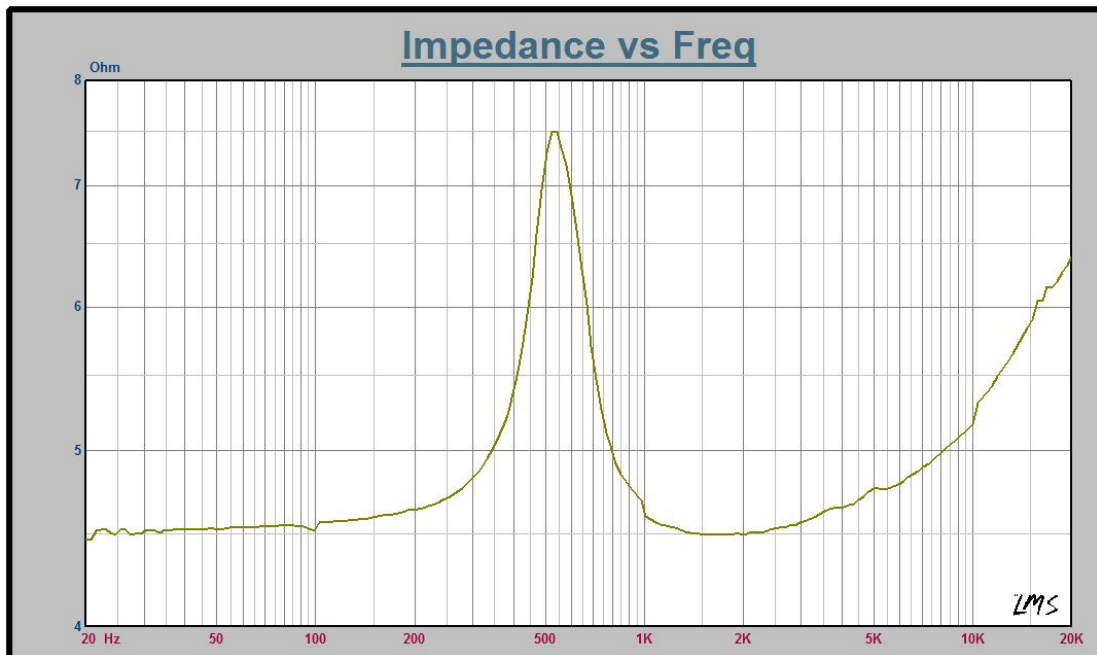

產品規格內容 (SPECIFICATION)

Model No.	XHXDZ-20MM 圓形-4R3W	Date	2024-08-17	Page No.	5 / 6
-----------	--------------------	------	------------	----------	-------

8. 喇叭外觀描述

(Unit:mm tolerance:±0.3)

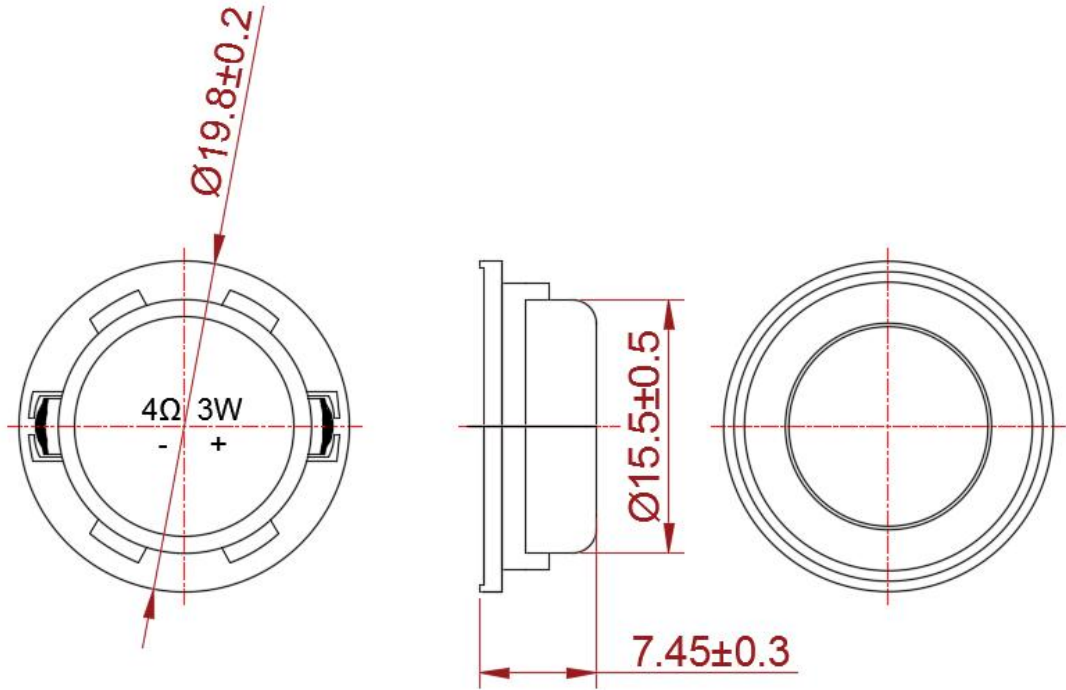

產品規格內容 (SPECIFICATION)

Model No.	XHXDZ-20MM 圓形-4R3W	Date	2024-08-17	Page No.	6/6
-----------	--------------------	------	------------	----------	-----

9. 包裝示意圖(Packing Standard):

(Unit:cm tolerance:±3)

