



## SPECIFICATION FOR APPROVAL

# 承 认 书

Description : 蜂鸣器 Buzzer

Vender's Part No. : Cy-12075-5025

Cstomer name : \_\_\_\_\_

Supplier name : 常州超音电子有限公司

Version No. : 1.1

CUSTOMER'S APPROVED SIGNATURE		

CHANGZHOU CHAOYIN ELECTRONIC CO., LTD  
常州超音电子有限公司

ADD:中国常州武进庙桥新联工业集中区 58 号

TEL: +86-519-88298758

FAX: +86-519-86464158

Http://www.smdbuzzer.net

Approved By	Checked By	Made By
		<b>Nong</b> <b>2014/04/29</b>

## A. SCOPE

This specification applies magnetic buzzer, **Cy-12075-5025**

## B. SPECIFICATION

No.	Item	Unit	Specification	Condition
1	Oscillation Frequency	KHz	$2.3 \pm 0.3$	
2	Operating Voltage	Vdc	4-7	
3	Rated Voltage	Vdc	5	
4	Current Consumption	mA	MAX. $\leq 30$	at Rated Voltage
5	Sound Pressure Level	dB	MIN.85	at 10cm at Rated Voltage
6	Operating Temperature	°C	-30~ +70	
7	Storage Temperature	°C	-40 ~ +80	
8	Dimension	mm	$\Phi 12^* H7.5$	See appearance drawing
9	Weight (MAX)	gram	1.5	
10	Housing Material		MPPO ( Black )	
11	Leading Pin		Tin Plated Brass(Sn)	See appearance drawing
12	Environmental Protection Regulation		RoHS	

## C. APPEARANCE DRAWING : Tol : $\pm 0.5$ Unit: mm

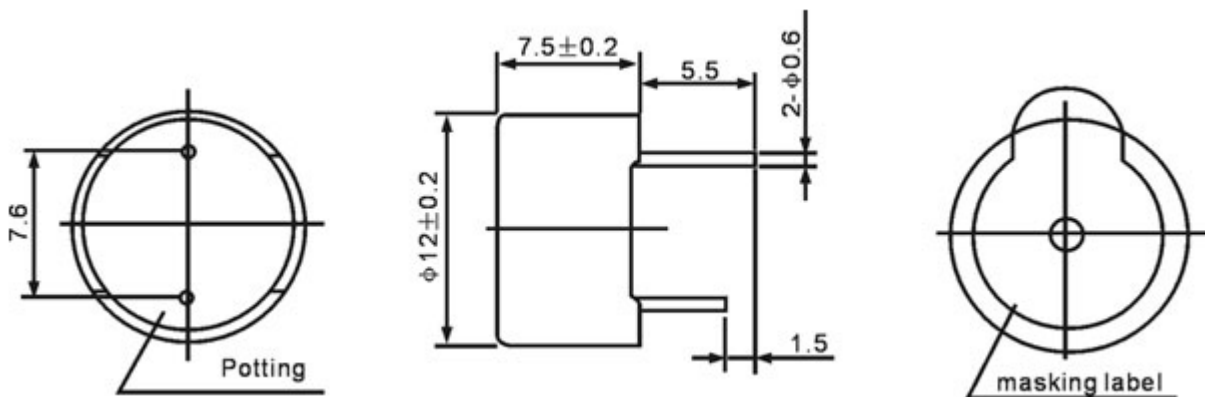

## D. TESTING METHOD

### Standard Measurement conditions

Temperature:  $25 \pm 2^\circ\text{C}$  Humidity: 45-65%

### Acoustic Characteristics:

The oscillation frequency, current consumption and sound pressure are measured by the measuring instruments shown below

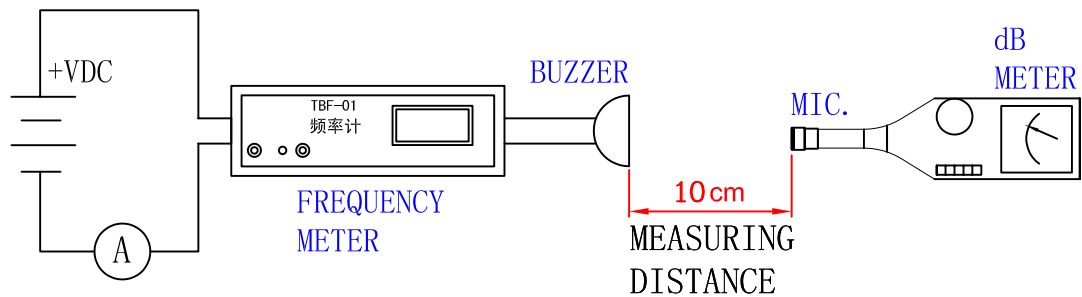

In the measuring test, buzzer is placed as follows

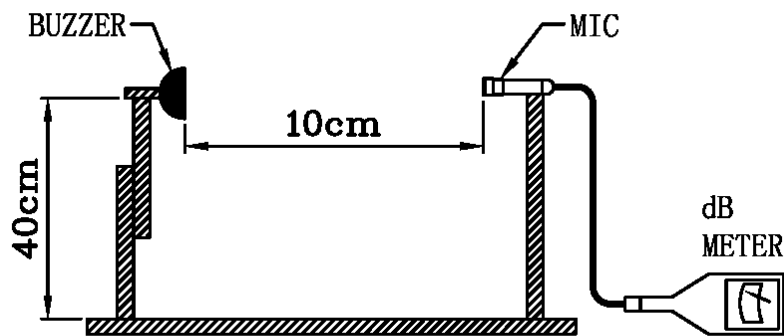

## E. RELIABILITY TEST

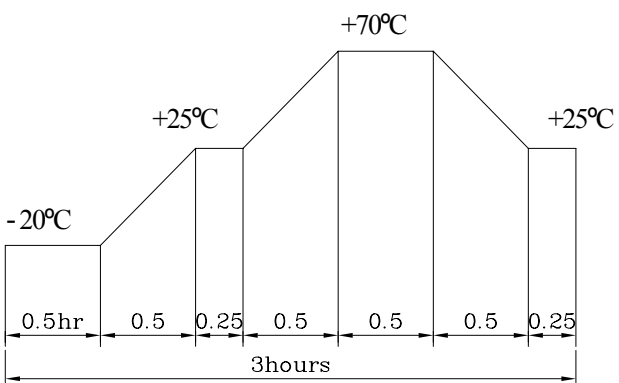
NO.	ITEM	TEST CONDITION AND REQUIREMENT
1	High Temperature Test (Storage)	After being placed in a chamber with $80\pm 2^{\circ}\text{C}$ for 96 hours and then being placed in normal condition for 2 hours. Allowable variation of SPL after test: $\pm 10\text{dB}$ .
2	Low Temperature Test (Storage)	After being Placed in a chamber with $-30\pm 2^{\circ}\text{C}$ for 96 hours and then being placed in normal condition for 2 hours. Allowable variation of SPL after test: $\pm 10\text{dB}$ .
3	Humidity Test	After being Placed in a chamber with 90-95% R.H. at $40\pm 2^{\circ}\text{C}$ for 96 hours and then being placed in normal condition for 2 hours. Allowable variation of SPL after test: $\pm 10\text{dB}$ .
4	Temperature Cycle Test	<p>The part shall be subjected to 5 cycles. One cycle shall be consist of :</p>  <p>Allowable variation of SPL after test: <math>\pm 10\text{dB}</math>.</p>
5	Drop Test	Drop on a hard wood board of 4cm thick, any directions ,6 times, at the height of 75cm . Allowable variation of SPL after test: $\pm 10\text{dB}$ .
6	Vibration Test	After being applied vibration of amplitude of 1.5mm with 10 to 55 Hz band of vibration frequency to each of 3 perpendicular directions for 2 hours . Allowable variation of SPL after test: $\pm 10\text{dB}$ .
7	Solderability Test	Lead terminals are immersed in rosin for 5 seconds and then immersed in solder bath of $+300\pm 5^{\circ}\text{C}$ for $3\pm 1$ seconds . 90% min. lead terminals shall be wet with solder (Except the edge of terminals).
8	Terminal Strength Pulling Test	The force of 9.8N(1.0kg) is applied to each terminal in axial direction for 10 seconds. No visible damage and cutting off.

### TEST CONDITION.

Standard Test Condition	:	a) Temperature : $+5 \sim +35^{\circ}\text{C}$	b) Humidity : 45-85%	c) Pressure : 860-1060mbar
一般测试条件	:	a) 温度 : $+5 \sim +35^{\circ}\text{C}$	b) 湿度 : 45-85%	c) 气压 : 860-1060mbar
Judgment Test Condition	:	a) Temperature : $+25 \pm 2^{\circ}\text{C}$	b) Humidity : 60-70%	c) Pressure : 860-1060mbar
争议时测试条件	:	a) 温度 : $+25 \pm 2^{\circ}\text{C}$	b) 湿度 : 60-70%	c) 气压 : 860-1060mbar

# F. PACKING STANDARD

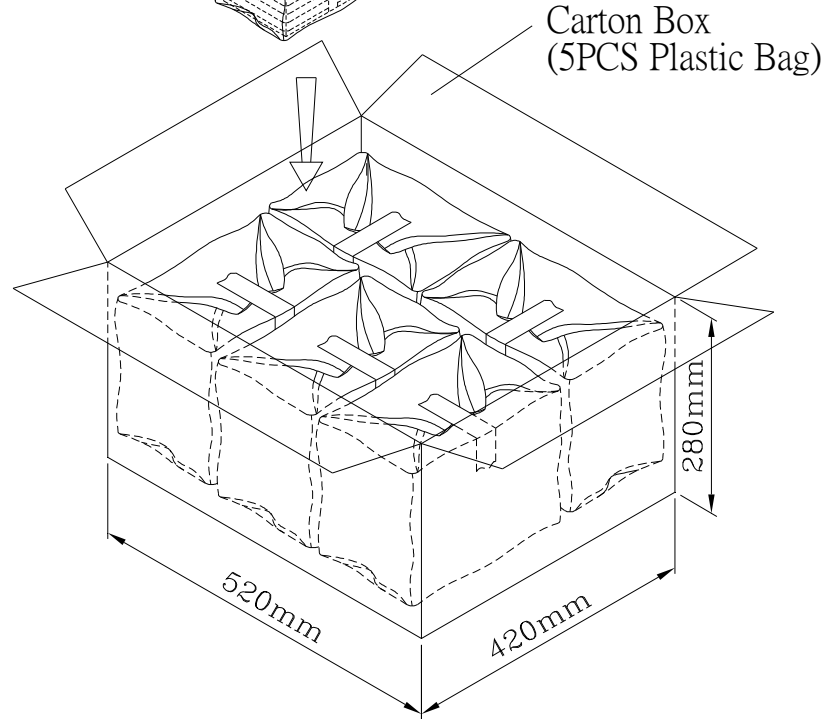
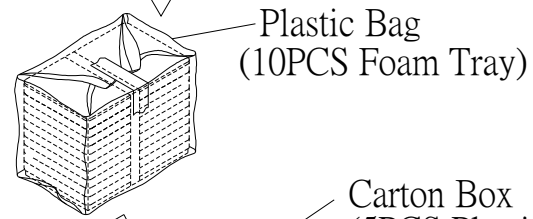
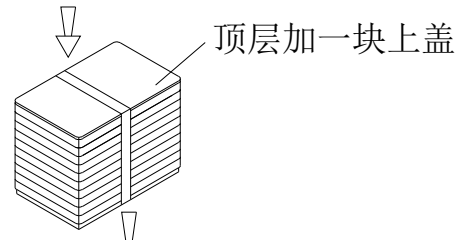
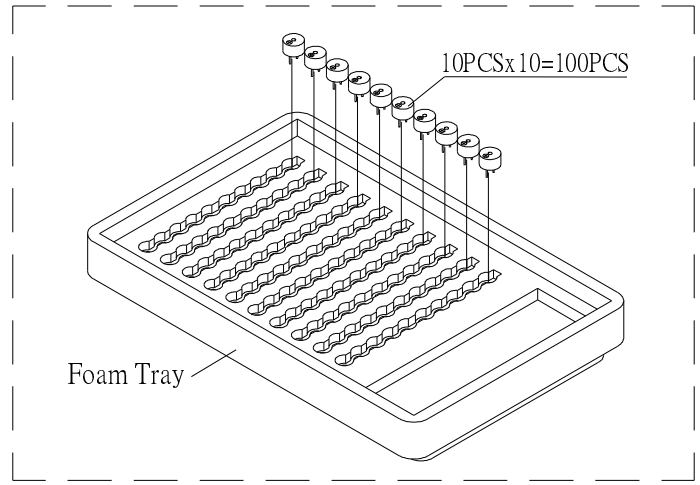

Foam Tray	240mmx160mmx30mm	1x100PCS=100PCS
Plastic Bag		10x100PCS=1000PCS
Carton Box	520mmx420mmx280mm	5x1000PCS=5,000PCS