



Single Buffer/Line Driver: 3-state

CJ74AHC/AHCT1G126 Logic

1 Introduction

CJ74AHC1G126 and CJ74AHCT1G126 are single buffer/line drivers with 3-state output.

2 Available Packages

PART NUMBER	PACKAGE
CJ74AHC1G126	SOT-23-5L
	SOT-353
	DFN1x1-6L
	DFN1.45x1-6L
CJ74AHCT1G126	SOT-23-5L
	SOT-353
	DFN1x1-6L
	DFN1.45x1-6L

Note: For all available packages, please refer to the part Orderable Information.

3 Features

- Power supply voltage range:
 - CJ74AHC1G126: 2V to 5.5V
 - CJ74AHCT1G126: 4.5V to 5.5V
- Low power dissipation
- Specified from -40°C to +125°C

4 Applications

- Projectors
- TVs
- Servers
- Motor controls
- Patient monitoring
- Electronic points of sale

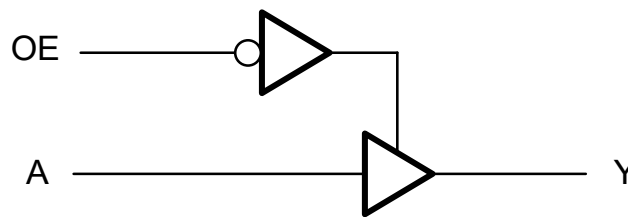

Simplified schematic

5 Orderable Information

DEVICE	PACKAGE	OP TEMP	ECO PLAN	MSL	PACKING OPTION	SORT
CJ74AHC1G126M5N	SOT-23-5L	-40~125°C	RoHS & Green	Level 3 168HR	Tape and Reel 3000 Units / Reel	Active
CJ74AHCT1G126M5N	SOT-23-5L	-40~125°C	RoHS & Green	Level 3 168HR	Tape and Reel 3000 Units / Reel	Active
CJ74AHC1G126R5N	SOT-353	-40~125°C	RoHS & Green	Level 3 168HR	Tape and Reel 3000 Units / Reel	Active
CJ74AHCT1G126R5N	SOT-353	-40~125°C	RoHS & Green	Level 3 168HR	Tape and Reel 3000 Units / Reel	Active
CJ74AHC1G126DKN	DFN1x1-6L	-40~125°C	RoHS & Green	Level 3 168HR	Tape and Reel 5000 Units / Reel	Active
CJ74AHCT1G126DKN	DFN1x1-6L	-40~125°C	RoHS & Green	Level 3 168HR	Tape and Reel 5000 Units / Reel	Active
CJ74AHC1G126DNN	DFN1.45x1-6L	-40~125°C	RoHS & Green	Level 3 168HR	Tape and Reel 5000 Units / Reel	Active
CJ74AHCT1G126DNN	DFN1.45x1-6L	-40~125°C	RoHS & Green	Level 3 168HR	Tape and Reel 5000 Units / Reel	Active

Note:

ECO PLAN: For the RoHS and Green certification standards of this product, please refer to the official report provided by JSCJ.

MSL: Moisture Sensitivity Level. Determined according to JEDEC industry standard classification.

SORT: Specifically defined as follows:

Active: Recommended for new products;

Customized: Products manufactured to meet the specific needs of customers;

Preview: The device has been released and has not been fully mass produced. The sample may or may not be available;

NoRD: It is not recommended to use the device for new design. The device is only produced for the needs of existing customers;

Obsolete: The device has been discontinued.

6 Pin Configuration and Marking Information

6.1 Pin Configuration

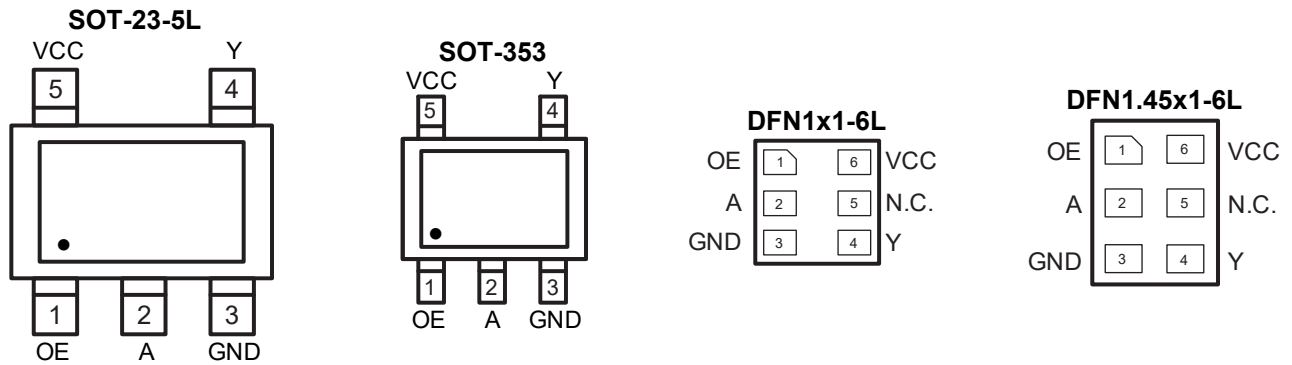

Figure 6-1 Pin configuration

6.2 Pin Function

PIN		NAME	I/O ⁽¹⁾	DESCRIPTION
No.				
SOT-23-5L	DFN1x1-6L			
SOT-353	DFN1.45x1-6L			
1	1	OE	I	Output enable input
2	2	A	I	Data input
3	3	GND	G	Ground (0V)
4	4	Y	O	Data output
-	5	N.C.	-	Not connected
5	6	VCC	P	Supply voltage

(1) I-Input, O-Output, P-Power, G-Ground

6.3 Marking Information

6.3.1 CJ74AHC1G126

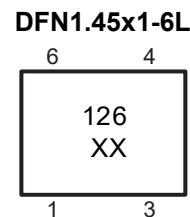
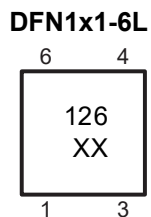
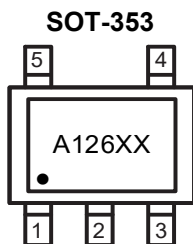
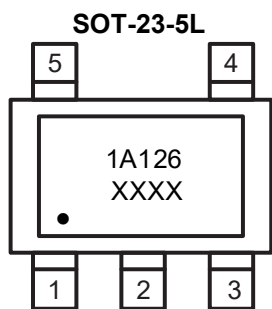

XXXX or XX: Code, indicates weekly record information.

6.3.2 CJ74AHCT1G126

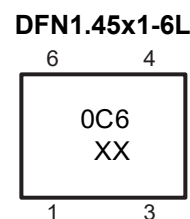
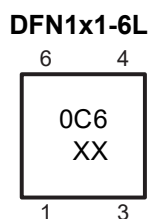
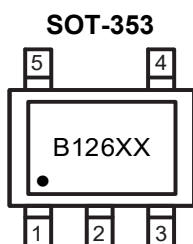
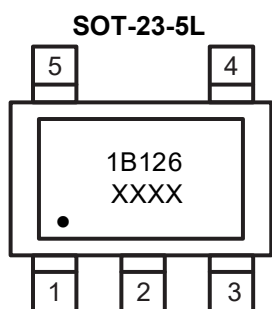

XXXX or XX: Code, indicates weekly record information.

7 Specifications

7.1 Absolute Maximum Ratings

$T_{amb}=25^{\circ}\text{C}$, all voltage referenced to GND, unless otherwise specified.

SYMBOL	PARAMETER	CONDITIONS	MIN.	MAX.	UNIT
V_{CC}	Supply voltage	-	-0.5	+7.0	V
V_I	Input voltage	-	-0.5	+7.0	V
I_{IK}	Input clamping current	$V_I < -0.5\text{V}$	-20	-	mA
I_{OK}	Output clamping current	$V_O < -0.5\text{V}$ or $V_O > V_{CC} + 0.5\text{V}$	-	± 20	mA
I_O	Output current	$-0.5\text{V} < V_O < V_{CC} + 0.5\text{V}$	-	± 25	mA
I_{CC}	Supply current	-	-	75	mA
I_{GND}	Ground current	-	-75	-	mA
T_{stg}	Storage temperature	-	-65	+150	$^{\circ}\text{C}$
T_L	Soldering temperature	10s	-	260	$^{\circ}\text{C}$

Note: Absolute maximum ratings indicate sustained limits beyond which damage to the device may occur. All voltage parameters are absolute voltages referenced to GND. The thermal resistance and power dissipation ratings are measured under board mounted and still air conditions.

7.2 Recommended Operating Conditions

Voltages are referenced to GND (ground=0V), unless otherwise specified.

SYMBOL	PARAMETER	CONDITIONS	MIN.	TYP.	MAX.	UNIT
CJ74AHC1G126						
V_{CC}	Supply voltage	-	2.0	5.0	5.5	V
V_I	Input voltage	-	0	-	5.5	V
V_O	Output voltage	-	0	-	V_{CC}	V
T_{amb}	Ambient temperature	-	-40	-	+125	$^{\circ}\text{C}$
CJ74AHCT1G126						
V_{CC}	Supply voltage	-	4.5	5.0	5.5	V
V_I	Input voltage	-	0	-	5.5	V
V_O	Output voltage	-	0	-	V_{CC}	V
T_{amb}	Ambient temperature	-	-40	-	+125	$^{\circ}\text{C}$

7.3 ESD Ratings

SYMBOL	ESD RATINGS		VALUE	UNIT
$V_{ESD-HBM}$	Electrostatic discharge	Human body model (HBM) ⁽¹⁾	± 2000	V

(1) JEDEC document JEP155 states that 500-V HBM allows safe manufacturing with a standard ESD control process.

7.4 Electrical Characteristics
7.4.1 DC Characteristics 1
 $T_{amb} = -40^{\circ}\text{C}$ to $+85^{\circ}\text{C}$, voltages are referenced to GND (ground=0V), unless otherwise specified.

SYMBOL	PARAMETER	CONDITIONS	MIN.	TYP.	MAX.	UNIT
CJ74AHC1G126						
V_{IH}	HIGH-level input voltage	$V_{CC}=2.0\text{V}$	1.5	-	-	V
		$V_{CC}=3.0\text{V}$	2.1	-	-	V
		$V_{CC}=5.5\text{V}$	3.85	-	-	V
V_{IL}	LOW-level input voltage	$V_{CC}=2.0\text{V}$	-	-	0.5	V
		$V_{CC}=3.0\text{V}$	-	-	0.9	V
		$V_{CC}=5.5\text{V}$	-	-	1.65	V
V_{OH}	HIGH-level output voltage	$I_o=-50\mu\text{A}; V_{CC}=2.0\text{V}$	1.9	2.0	-	V
		$I_o=-50\mu\text{A}; V_{CC}=3.0\text{V}$	2.9	3.0	-	V
		$I_o=-50\mu\text{A}; V_{CC}=4.5\text{V}$	4.4	4.5	-	V
		$I_o=-4\text{mA}; V_{CC}=3.0\text{V}$	2.48	-	-	V
		$I_o=-8\text{mA}; V_{CC}=4.5\text{V}$	3.8	-	-	V
V_{OL}	LOW-level output voltage	$I_o=50\mu\text{A}; V_{CC}=2.0\text{V}$	-	0	0.1	V
		$I_o=50\mu\text{A}; V_{CC}=3.0\text{V}$	-	0	0.1	V
		$I_o=50\mu\text{A}; V_{CC}=4.5\text{V}$	-	0	0.1	V
		$I_o=4\text{mA}; V_{CC}=3.0\text{V}$	-	-	0.44	V
		$I_o=8\text{mA}; V_{CC}=4.5\text{V}$	-	-	0.44	V
I_{OZ}	OFF-state output current	$V_i=V_{CC}$ or GND; $V_{CC}=5.5\text{V}$	-	-	± 2.5	μA
I_i	Input leakage current	$V_i=5.5\text{V}$ or GND; $V_{CC}=0\text{V}$ to 5.5V	-	-	1.0	μA
I_{CC}	Supply current	$V_i=V_{CC}$ or GND; $I_o=0\text{A}$; $V_{CC}=5.5\text{V}$	-	-	20	μA
CJ74AHCT1G126						
V_{IH}	HIGH-level input voltage	$V_{CC}=4.5\text{V}$ to 5.5V	2.0	-	-	V
V_{IL}	LOW-level input voltage	$V_{CC}=4.5\text{V}$ to 5.5V	-	-	0.8	V
V_{OH}	HIGH-level output voltage	$I_o=-50\mu\text{A}; V_{CC}=4.5\text{V}$	4.4	4.5	-	V
		$I_o=-8\text{mA}; V_{CC}=4.5\text{V}$	3.8	-	-	V
V_{OL}	LOW-level output voltage	$I_o=50\mu\text{A}; V_{CC}=4.5\text{V}$	-	0	0.1	V
		$I_o=8\text{mA}; V_{CC}=4.5\text{V}$	-	-	0.44	V
I_{OZ}	OFF-state output current	$V_i=V_{CC}$ or GND; $V_{CC}=5.5\text{V}$	-	-	± 2.5	μA
I_i	Input leakage current	$V_i=5.5\text{V}$ or GND; $V_{CC}=0\text{V}$ to 5.5V	-	-	1.0	μA
I_{CC}	Supply current	$V_i=V_{CC}$ or GND; $I_o=0\text{A}$; $V_{CC}=5.5\text{V}$	-	-	20	μA
ΔI_{CC}	Additional supply current	Per input pin; $V_i=3.4\text{V}$; Other inputs at V_{CC} or GND; $I_o=0\text{A}$; $V_{CC}=5.5\text{V}$	-	-	1.5	mA

7.4.2 DC Characteristics 2
 $T_{amb} = -40^{\circ}\text{C}$ to $+125^{\circ}\text{C}$, voltages are referenced to GND (ground=0V), unless otherwise specified.

SYMBOL	PARAMETER	CONDITIONS	MIN.	TYP.	MAX.	UNIT
CJ74AHC1G126						
V_{IH}	HIGH-level input voltage	$V_{CC}=2.0\text{V}$	1.5	-	-	V
		$V_{CC}=3.0\text{V}$	2.1	-	-	V
		$V_{CC}=5.5\text{V}$	3.85	-	-	V
V_{IL}	LOW-level input voltage	$V_{CC}=2.0\text{V}$	-	-	0.5	V
		$V_{CC}=3.0\text{V}$	-	-	0.9	V
		$V_{CC}=5.5\text{V}$	-	-	1.65	V
V_{OH}	HIGH-level output voltage	$I_o=-50\mu\text{A}; V_{CC}=2.0\text{V}$	1.9	-	-	V
		$I_o=-50\mu\text{A}; V_{CC}=3.0\text{V}$	2.9	-	-	V
		$I_o=-50\mu\text{A}; V_{CC}=4.5\text{V}$	4.4	-	-	V
		$I_o=-4\text{mA}; V_{CC}=3.0\text{V}$	2.4	-	-	V
		$I_o=-8\text{mA}; V_{CC}=4.5\text{V}$	3.7	-	-	V
V_{OL}	LOW-level output voltage	$I_o=50\mu\text{A}; V_{CC}=2.0\text{V}$	-	-	0.1	V
		$I_o=50\mu\text{A}; V_{CC}=3.0\text{V}$	-	-	0.1	V
		$I_o=50\mu\text{A}; V_{CC}=4.5\text{V}$	-	-	0.1	V
		$I_o=4\text{mA}; V_{CC}=3.0\text{V}$	-	-	0.55	V
		$I_o=8\text{mA}; V_{CC}=4.5\text{V}$	-	-	0.55	V
I_{OZ}	OFF-state output current	$V_I=V_{CC}$ or GND; $V_{CC}=5.5\text{V}$	-	-	± 10	μA
I_I	Input leakage current	$V_I=5.5\text{V}$ or GND; $V_{CC}=0\text{V}$ to 5.5V	-	-	2.0	μA
I_{CC}	Supply current	$V_I=V_{CC}$ or GND; $I_o=0\text{A}$; $V_{CC}=5.5\text{V}$	-	-	40	μA
CJ74AHCT1G126						
V_{IH}	HIGH-level input voltage	$V_{CC}=4.5\text{V}$ to 5.5V	2.0	-	-	V
V_{IL}	LOW-level input voltage	$V_{CC}=4.5\text{V}$ to 5.5V	-	-	0.8	V
V_{OH}	HIGH-level output voltage	$I_o=-50\mu\text{A}; V_{CC}=4.5\text{V}$	4.4	-	-	V
		$I_o=-8\text{mA}; V_{CC}=4.5\text{V}$	3.7	-	-	V
V_{OL}	LOW-level output voltage	$I_o=50\mu\text{A}; V_{CC}=4.5\text{V}$	-	-	0.1	V
		$I_o=8\text{mA}; V_{CC}=4.5\text{V}$	-	-	0.55	V
I_{OZ}	OFF-state output current	$V_I=V_{CC}$ or GND; $V_{CC}=5.5\text{V}$	-	-	± 10	μA
I_I	Input leakage current	$V_I=5.5\text{V}$ or GND; $V_{CC}=0\text{V}$ to 5.5V	-	-	2.0	μA
I_{CC}	Supply current	$V_I=V_{CC}$ or GND; $I_o=0\text{A}$; $V_{CC}=5.5\text{V}$	-	-	40	μA
ΔI_{CC}	Additional supply current	Per input pin; $V_I=3.4\text{V}$; Other inputs at V_{CC} or GND; $I_o=0\text{A}$; $V_{CC}=5.5\text{V}$	-	-	1.5	mA

7.4.3 AC Characteristics 1

T_{amb}=-40°C to +85°C, GND=0V, unless otherwise specified.

SYMBOL	PARAMETER	CONDITIONS	MIN.	TYP.	MAX.	UNIT	
CJ74AHC1G126							
t _{PLH} , t _{PHL}	A to Y propagation delay	See Figure 8-4	C _L =15pF; V _{CC} =3.0V to 3.6V ⁽¹⁾	-	4.4	9.5	ns
			C _L =50pF; V _{CC} =3.0V to 3.6V ⁽¹⁾	-	6.3	13.0	ns
			C _L =15pF; V _{CC} =4.5V to 5.5V ⁽²⁾	-	3.4	6.5	ns
			C _L =50pF; V _{CC} =4.5V to 5.5V ⁽²⁾	-	4.7	8.5	ns
t _{PZL} , t _{PZH}	OE to Y enable time	See Figure 8-5	C _L =15pF; V _{CC} =3.0V to 3.6V ⁽¹⁾	-	4.9	9.5	ns
			C _L =50pF; V _{CC} =3.0V to 3.6V ⁽¹⁾	-	7.0	13.0	ns
			C _L =15pF; V _{CC} =4.5V to 5.5V ⁽²⁾	-	3.6	6.3	ns
			C _L =50pF; V _{CC} =4.5V to 5.5V ⁽²⁾	-	5.4	9.0	ns
t _{PLZ} , t _{PHZ}	OE to Y disable time	See Figure 8-5	C _L =15pF; V _{CC} =3.0V to 3.6V ⁽¹⁾	-	6.3	11.5	ns
			C _L =50pF; V _{CC} =3.0V to 3.6V ⁽¹⁾	-	9.0	15.0	ns
			C _L =15pF; V _{CC} =4.5V to 5.5V ⁽²⁾	-	4.3	8.0	ns
			C _L =50pF; V _{CC} =4.5V to 5.5V ⁽²⁾	-	6.1	10.0	ns
CJ74AHCT1G126							
t _{PLH} , t _{PHL}	A to Y propagation delay	See Figure 8-4	C _L =15pF; V _{CC} =4.5V to 5.5V ⁽²⁾	-	3.4	6.5	ns
			C _L =50pF; V _{CC} =4.5V to 5.5V ⁽²⁾	-	4.7	8.5	ns
t _{PZL} , t _{PZH}	OE to Y enable time	See Figure 8-5	C _L =15pF; V _{CC} =4.5V to 5.5V ⁽²⁾	-	3.4	6.3	ns
			C _L =50pF; V _{CC} =4.5V to 5.5V ⁽²⁾	-	4.8	9.0	ns
t _{PLZ} , t _{PHZ}	OE to Y disable time	See Figure 8-5	C _L =15pF; V _{CC} =4.5V to 5.5V ⁽²⁾	-	4.0	8.0	ns
			C _L =50pF; V _{CC} =4.5V to 5.5V ⁽²⁾	-	5.7	10.0	ns

(1) Typical values are measured at V_{CC}=3.3V.

(2) Typical values are measured at V_{CC}=5V.

7.4.4 AC Characteristics 2

T_{amb}=-40°C to +125°C, GND=0V, unless otherwise specified.

SYMBOL	PARAMETER	CONDITIONS	MIN.	TYP.	MAX.	UNIT	
CJ74AHC1G126							
t _{PLH} ,t _{PHL}	A to Y propagation delay	See Figure 8-4	C _L =15pF; V _{CC} =3.0V to 3.6V	-	-	10.0	ns
			C _L =50pF; V _{CC} =3.0V to 3.6V	-	-	14.5	ns
			C _L =15pF; V _{CC} =4.5V to 5.5V	-	-	7.0	ns
			C _L =50pF; V _{CC} =4.5V to 5.5V	-	-	9.5	ns
t _{PZL} ,t _{PZH}	OE to Y enable time	See Figure 8-5	C _L =15pF; V _{CC} =3.0V to 3.6V	-	-	10.0	ns
			C _L =50pF; V _{CC} =3.0V to 3.6V	-	-	14.5	ns
			C _L =15pF; V _{CC} =4.5V to 5.5V	-	-	7.0	ns
			C _L =50pF; V _{CC} =4.5V to 5.5V	-	-	9.5	ns
t _{PLZ} ,t _{PHZ}	OE to Y disable time	See Figure 8-5	C _L =15pF; V _{CC} =3.0V to 3.6V	-	-	12.5	ns
			C _L =50pF; V _{CC} =3.0V to 3.6V	-	-	16.5	ns
			C _L =15pF; V _{CC} =4.5V to 5.5V	-	-	8.5	ns
			C _L =50pF; V _{CC} =4.5V to 5.5V	-	-	11.0	ns
CJ74AHCT1G126							
t _{PLH} ,t _{PHL}	A to Y propagation delay	See Figure 8-4	C _L =15pF; V _{CC} =4.5V to 5.5V	-	-	7.0	ns
			C _L =50pF; V _{CC} =4.5V to 5.5V	-	-	9.5	ns
t _{PZL} ,t _{PZH}	OE to Y enable time	See Figure 8-5	C _L =15pF; V _{CC} =4.5V to 5.5V	-	-	6.5	ns
			C _L =50pF; V _{CC} =4.5V to 5.5V	-	-	9.0	ns
t _{PLZ} ,t _{PHZ}	OE to Y disable time	See Figure 8-5	C _L =15pF; V _{CC} =4.5V to 5.5V	-	-	8.5	ns
			C _L =50pF; V _{CC} =4.5V to 5.5V	-	-	11.5	ns

8 Detailed Description

8.1 Overview

CJ74AHC1G126 and CJ74AHCT1G126 are single buffer/line drivers with 3-state output.

8.2 Functional Block Diagram

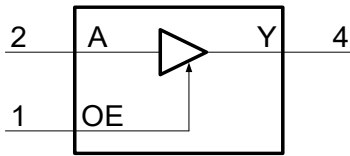

Figure 8-1 Logic symbol

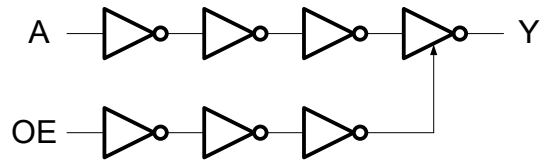

Figure 8-2 Logic diagram

8.3 Function Table⁽¹⁾

CONTROL	INPUT	OUTPUT
OE	A	Y
H	L	L
H	H	H
L	X	Z

(1) H=HIGH voltage level; L=LOW voltage level; X=don't care; Z=high-impedance OFF-state.

8.4 Testing Circuit

8.4.1 AC Testing Circuit

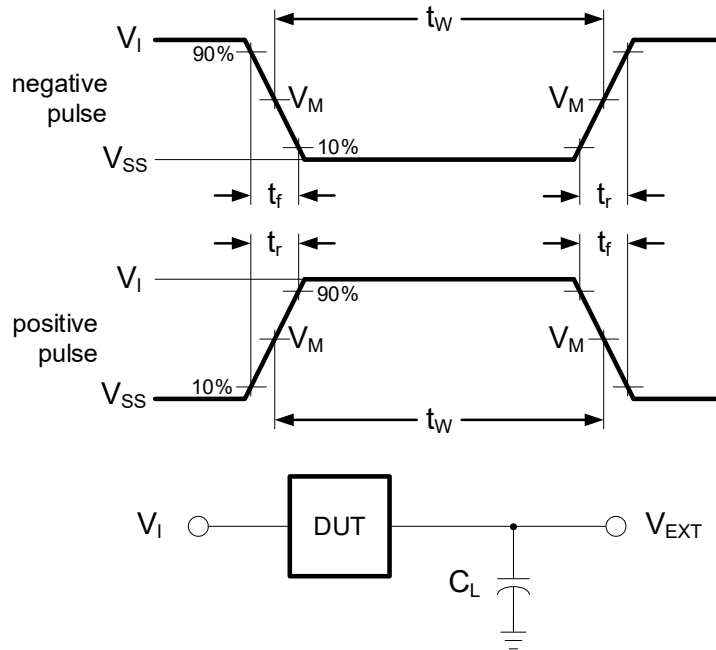

Figure 8-3 Test circuit for measuring switching times

Definitions test circuit:

C_L =Load capacitance including jig and probe capacitance.

8.4.2 AC Testing Waveforms

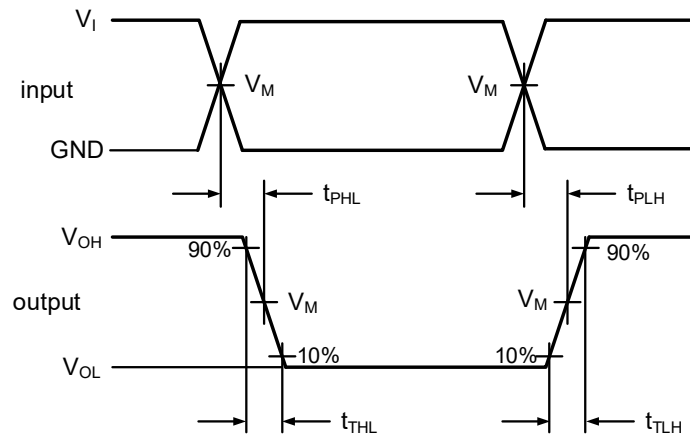

Figure 8-4 Input (A) to output (Y) propagation delays

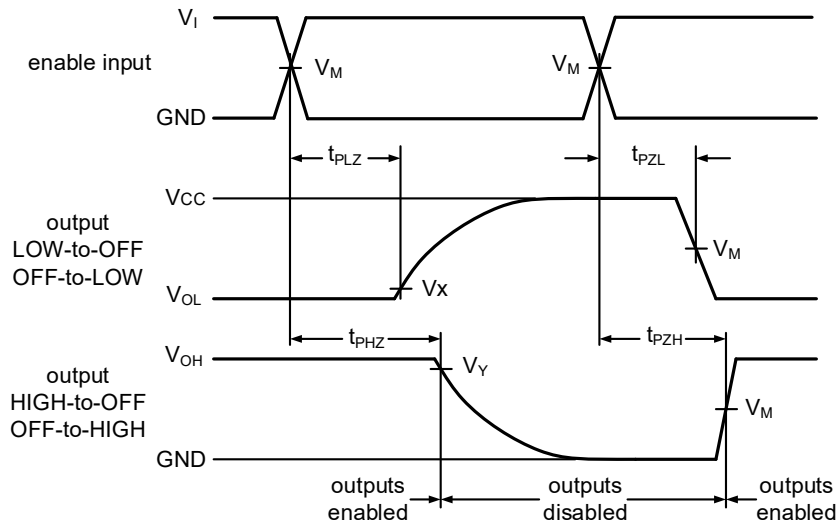

Figure 8-5 Enable and disable times

8.4.3 Measurement Points

TYPE	INPUT		OUTPUT	
	V_M	V_M	V_X	V_Y
CJ74AHC1G126	$0.5 \times V_{CC}$	$0.5 \times V_{CC}$	$V_{OL} + 0.3V$	$V_{OH} - 0.3V$
CJ74AHCT1G126	1.5V	$0.5 \times V_{CC}$	$V_{OL} + 0.3V$	$V_{OH} - 0.3V$

8.4.4 Test Data

TYPE	INPUT		LOAD		V_{EXT}		
	V_I	$t_r = t_f$	C_L	R_L	t_{PLH}/t_{PHL}	t_{PLZ}/t_{PZL}	t_{PHZ}/t_{PZH}
CJ74AHC1G126	V_{CC}	$\leq 3.0ns$	15pF, 50pF	1k Ω	Open	V_{CC}	GND
CJ74AHCT1G126	3.0V	$\leq 3.0ns$	15pF, 50pF	1k Ω	Open	V_{CC}	GND

9 Mechanical Information

9.1 SOT-23-5L Mechanical Information

9.1.1 SOT-23-5L Outline Dimensions

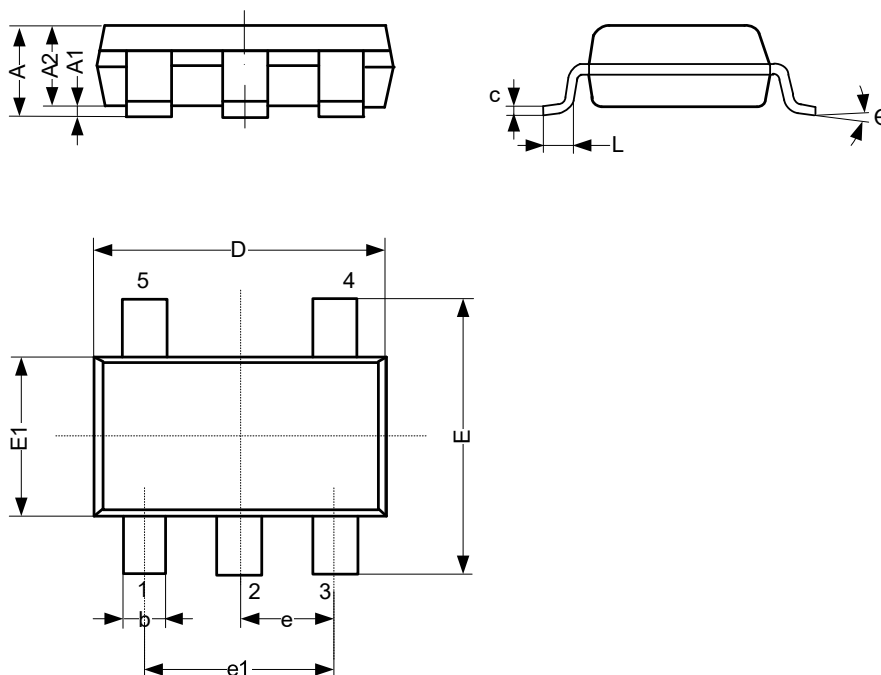

SYMBOL	Dimensions In Millimeters		
	Min.	Typ.	Max.
A	-	-	1.26
A1	0.00	-	0.12
A2	1.00	-	1.20
b	0.30	-	0.50
c	0.10	-	0.20
D	2.82	-	3.02
E	2.60	-	3.00
E1	1.50	-	1.70
e	0.95 BSC		
e1	1.80	-	2.00
L	0.30	-	0.60
Θ	0°	-	8°
Unit: mm			

9.2 SOT-353 Mechanical Information

9.2.1 SOT-353 Outline Dimensions

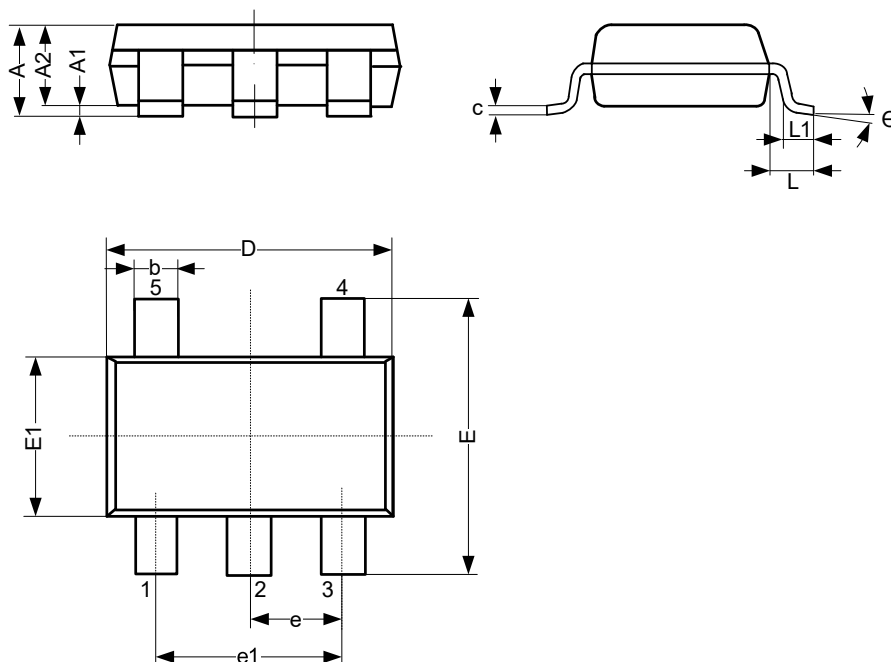

SYMBOL	Dimensions In Millimeters		
	Min.	Typ.	Max.
A	0.90	-	1.10
A1	0.00	-	0.10
A2	0.90	-	1.00
b	0.15	-	0.35
c	0.11	-	0.175
D	2.00	-	2.20
E	1.15	-	1.35
E1	2.15	-	2.45
e	0.65 BSC		
e1	1.20	-	1.40
L	-	0.525	-
L1	0.26	-	0.46
θ	0°	-	8°
Unit: mm			

9.3 DFN1x1-6L Mechanical Information

9.3.1 DFN1x1-6L Outline Dimensions

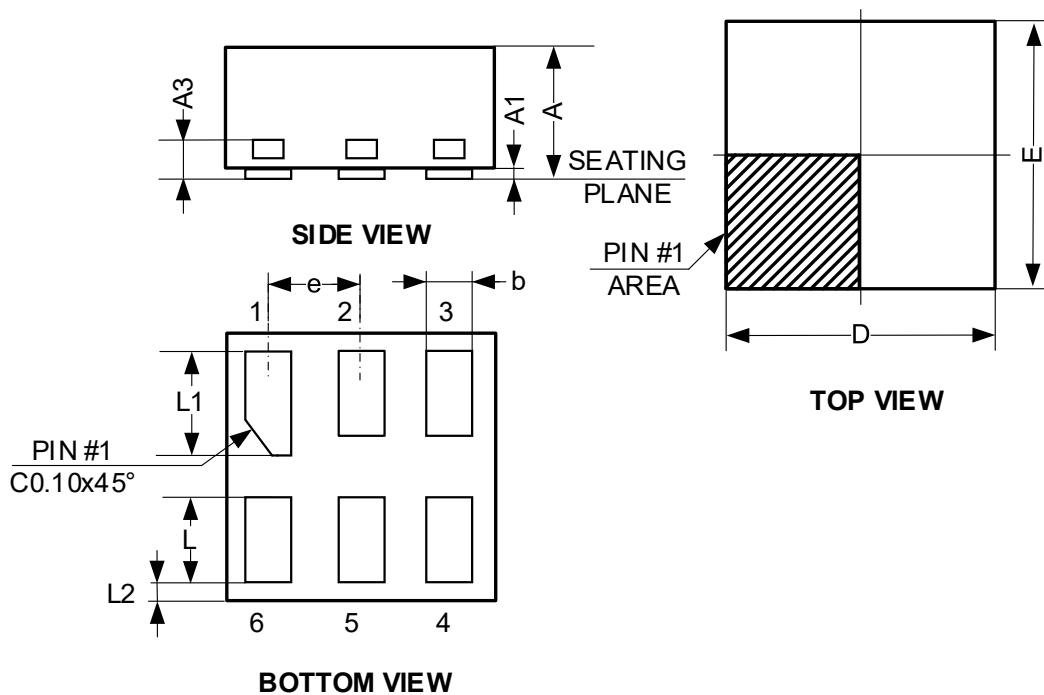

SYMBOL	Dimensions In Millimeters		
	Min.	Typ.	Max.
A	0.32	-	0.50
A1	0.00	-	0.05
A3	0.10	-	0.13
b	0.10	-	0.21
D	-	1.00	-
E	-	1.00	-
e	0.35 BSC		
L	0.25	-	0.36
L1	0.30	-	0.41
L2	0.02	-	0.12
Unit: mm			

9.4 DFN1.45x1-6L Mechanical Information

9.4.1 DFN1.45x1-6L Outline Dimensions

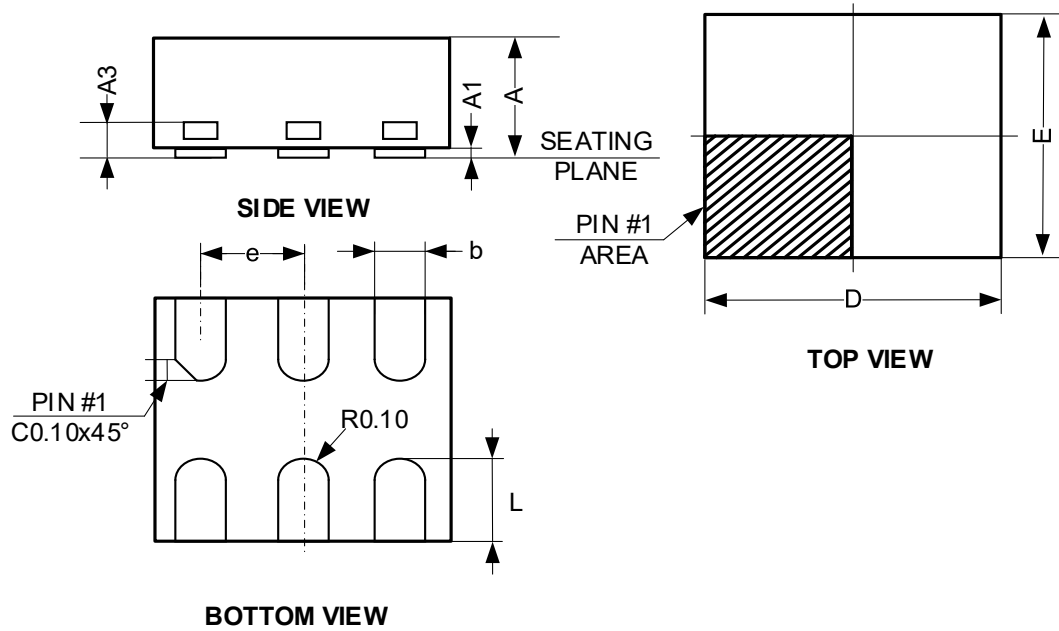

SYMBOL	Dimensions In Millimeters		
	Min.	Typ.	Max.
A	0.51	-	0.60
A1	0.00	-	0.05
A3	-	0.15	-
b	0.15	-	0.25
D	-	1.45	-
E	-	1.00	-
e	0.50 BSC		
L	0.25	-	0.45
Unit: mm			

10 Notes and Revision History

10.1 Associated Product Family and Others

To view other products of the same type or IC products of other types, click the official website of JSCJ -- <https://www.jscj-elec.com> for more details.

10.2 Notes

Electrostatic Discharge Caution



This IC may be damaged by ESD. Relevant personnel shall comply with correct installation and use specifications to avoid ESD damage to the IC. If appropriate measures are not taken to prevent ESD damage, the hazards caused by ESD include but are not limited to degradation of integrated circuit performance or complete damage of integrated circuit. For some precision integrated circuits, a very small parameter change may cause the whole device to be inconsistent with its published specifications.

DISCLAIMER

IMPORTANT NOTICE, PLEASE READ CAREFULLY

The information in this data sheet is intended to describe the operation and characteristics of our products. JSCJ has the right to make any modification, enhancement, improvement, correction or other changes to any content in this data sheet, including but not limited to specification parameters, circuit design and application information, without prior notice.

Any person who purchases or uses JSCJ products for design shall: 1. Select products suitable for circuit application and design; 2. Design, verify and test the rationality of circuit design; 3. Procedures to ensure that the design complies with relevant laws and regulations and the requirements of such laws and regulations. JSCJ makes no warranty or representation as to the accuracy or completeness of the information contained in this data sheet and assumes no responsibility for the application or use of any of the products described in this data sheet.

Without the written consent of JSCJ, this product shall not be used in occasions requiring high quality or high reliability, including but not limited to the following occasions: medical equipment, military facilities and aerospace. JSCJ shall not be responsible for casualties or property losses caused by abnormal use or application of this product.

Official Website: www.jscj-elec.com

Copyright © JIANGSU CHANGJING ELECTRONICS TECHNOLOGY CO., LTD