



KBJ4005G THUR KBJ410G

Single Phase 4.0 AMP Glass Passivated Bridge Rectifier

1.Features

- Glass Passivated Die Construction
- Low forward voltage drop
- High surge current capability.
- Plastic material-UL flammability 94V-0.

KBJ

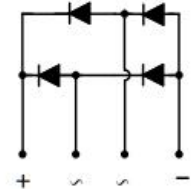

2.Mechanical Data

- Case:KBJ Molded Plastic .
- Terminals:Plated Leads Solderable per MIL-STD-202,Method208
- Polarity:As Marked on Case.
- Marking Information: Type Number.
- Mounting Position : Any.

3.Maximum Ratings and Electrical Characteristics

Rating at 25°C ambient temperature unless otherwise specified Single phase, half wave, 60Hz, resistive or inductive load
For capacitive load derate current by 20%

Type Number	Symbol	KBJ 4005G	KBJ 401G	KBJ 402G	KBJ 404G	KBJ 406G	KBJ 408G	KBJ 410G	Unit
Peak Repetitive Reverse Voltage	V_{RRM}	50	100	200	400	600	800	1000	V
Working Peak Reverse Voltage	V_{RWM}								
DC Blocking Voltage	V_{DC}								
RMS Reverse Voltage	V_{RMS}	35	70	140	280	420	560	700	V
Maximum average forward rectified current(Note2)	$I_{F(AV)}$	4							A
Peak Forward Surge Current 8.3ms Single half sine-wave superimposed on rated load (JEDEC Method)	I_{FSM}	130							A
I^2t Rating for fusing (t < 8.3ms)	I^2t	70							A ² s
Forward Voltage per element @ $I_F=2.0A$ @ $I_F=4.0A$	V_{FM}	1.0							V
		1.1							V
Peak Reverse Current @ $T_J=25\text{ }^\circ\text{C}$ At Rated DC Blocking Voltage @ $T_J=125\text{ }^\circ\text{C}$	I_R	5							uA
		500							
Typical Junction Capacitance (Note 1)	C_J	35							pF
Typical Thermal Resistance (Note2)	$R_{\theta JC}$	5.5							°C/W
Dielectric Strength	V_{ids}	2500							V
The proposed installation torque	Tor	5							Kgf.cm
Max torque		8							
Operating Temperature Range	T_J	-55 to +150							°C
Storage Temperature Range	T_{STG}	-55 to +150							°C

Note:

1. Measured at 1.0 MHz and applied reverse voltage of 4.0V D.C
2. Device mounted on 50mm x 50mm x 1.6mm Cu Plate Heatsink.



4. Rating And Characteristic Curves

Fig. 1 Forward Current Derating Curve

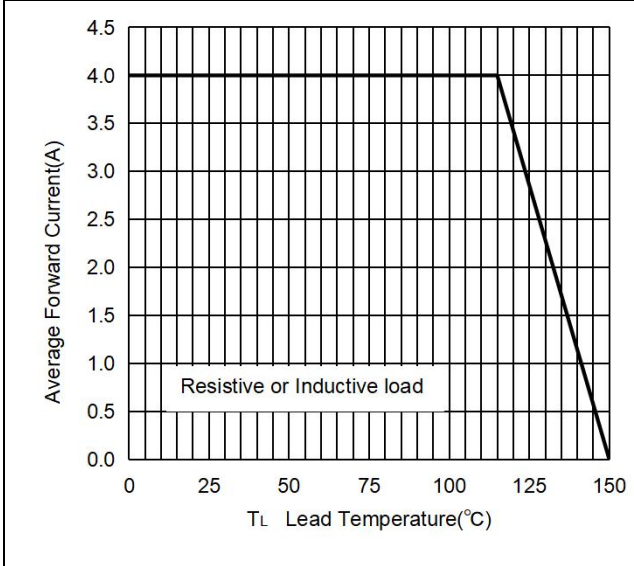

Fig. 2 Typ. Forward Characteristics

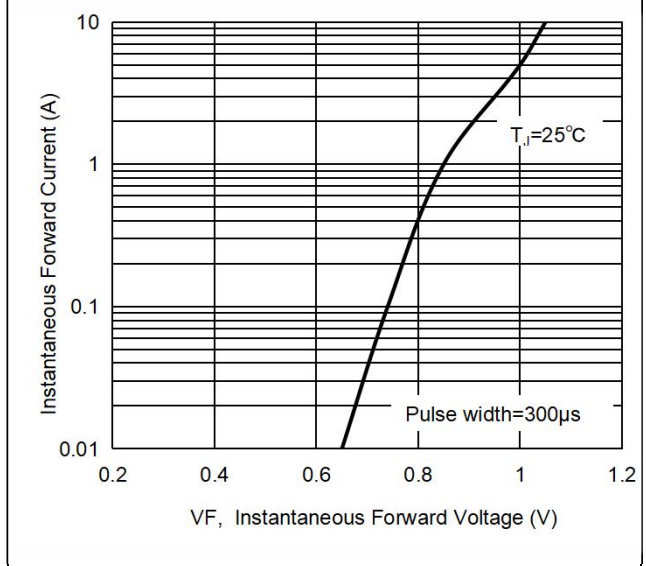

Fig.3 Maximum Peak Forward Surge Current

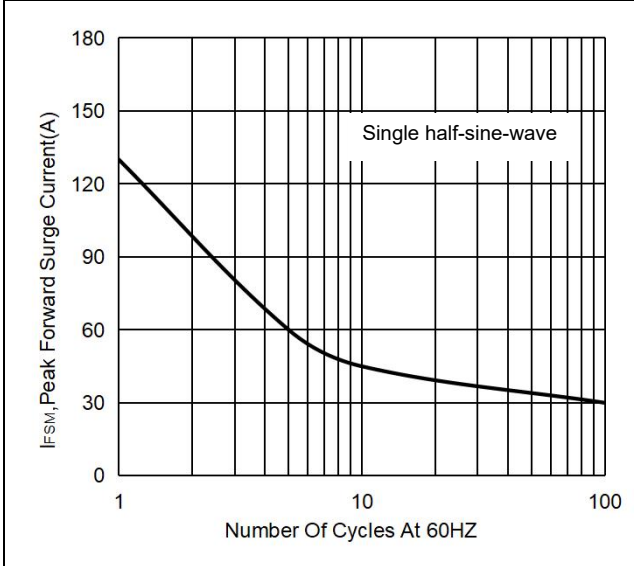
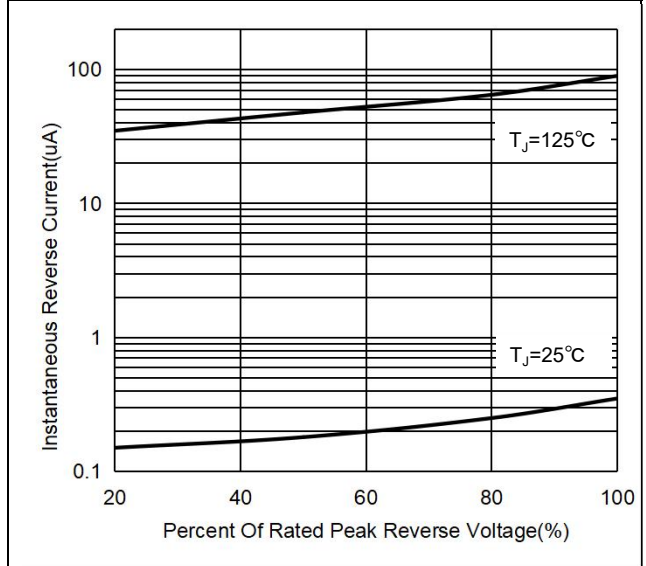

Fig.4 Typical Reverse Characteristics





KBJ4005G THUR KBJ410G

Single Phase 4.0 AMP Glass Passivated Bridge Rectifier

5. Dimensions

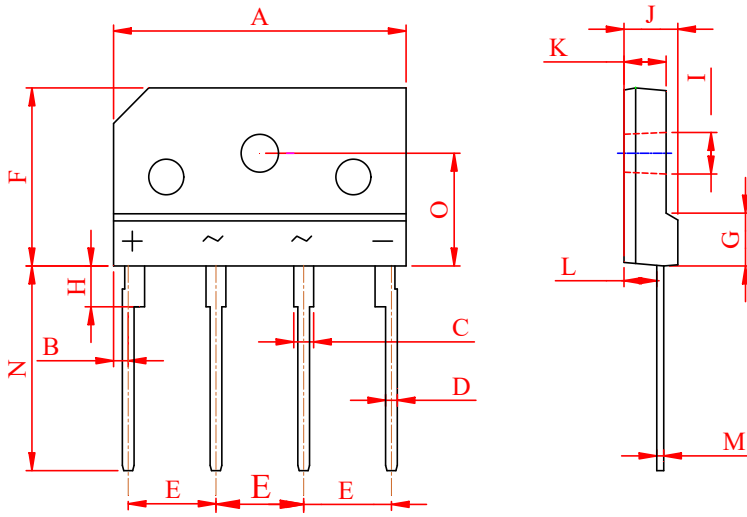

Dimensions	Inches		Millimeters	
	Min	Max	Min	Max
A	0.972	0.996	24.70	25.30
B	0.037	0.057	0.95	1.45
C	0.059	0.075	1.50	1.90
D	0.035	0.043	0.90	1.10
E	0.287	0.303	7.30	7.70
F	0.579	0.602	14.70	15.30
G	0.157		4.00	
H	0.130	0.146	3.30	3.70
I	0.122	0.138	3.10	3.50
J	0.173	0.189	4.40	4.80
K	0.126	0.150	3.20	3.80
L	0.098	0.114	2.50	2.90
M	0.016	0.031	0.40	0.80
N	0.630	0.709	16.00	18.00
O	0.366	0.390	9.30	9.90



KBJ4005G THUR KBJ410G

Single Phase 4.0 AMP Glass Passivated Bridge Rectifier

Important Notice and Disclaimer

- Reproducing and modifying information of the document is prohibited without from XINNUO.
- XINNUO reserves the right to make changes to this document and its products and specifications.
- XINNUO disclaims any and all liability arising out of the application or use of any product including damages incidentally and consequentially occurred.
- XINNUO does not assume any and all implied warranties, including warranties of fitness for particular purpose, non-infringement and merchantability.
- Applications shown on the here in document are examples of standard use and operation. Customers are responsible in comprehending the suitable use in particular applications. XINNUO makes no representation or warranty that such applications will be suitable for the specified use without further testing or modification.
- The products shown her are not designed and authorized for equipments requiring high level of reliability or relating to human life and for any applications concerning life-saving or life-sustaining, such as medical instruments, transportation equipment, aerospace machinery et cetera. Customers using or selling these products for use in such applications do so at their own risk and agree to fully indemnify XINNUO for any damages resulting from such improper use or sale.
- Since XINNUO uses lot number as the tracking base, please provide the lot number for tracking when complaining.