

Shenzhen H-Great Optoelectronic Co., Ltd.

承认书 Approved Sheet

客户名称：	
客户物料名称：	
客户物料编码：	
文件编号：	
华皓品名：	<u>P28-W003P02Z1S1SA01-AM</u>
华皓料号：	

客户

检测员：
审核：
批准：
盖章：

华皓

检测员：赵小吹
审核：刁发开
批准：黄增富
日期：20240830

P28-W003P02Z1S1SA01-AM

The Ultra high reliability and luminous efficacy ,PLCC LED Series are optimized to be used as lighting for automotive signal lighting designs or signboard.



Applications/产品应用

Automotive Interior/Exterior Lighting
Traffic Lighting
Signal Lighting

汽车内/外照明
交通照明
信号灯

Features/特性

Size(mm) : 2.8*3.5*0.7
Color : white
Thermal resistance: 42K/W
Viewing angle: 120°
ESD protection up to 8KV
Quality cations: The product quality cation test based on the guidelines of AECQ-102
MSL: Level 3
RoHS compliant

尺寸（毫米）：2.8*3.5*0.7
发光颜色：白光
热阻：42K/W
发光角度：120°
抗静电：8 kV
质量检测：AECQ-102
湿敏等级：Level 3
通过RoHS认证

P28-W003P02Z1S1SA01-AM

Absolute maximum ratings($T_a=25^{\circ}\text{C}$)/最大额定值

Parameters/参数	Symbol/符号	Value/数值	Unit/单位
Power dissipated 功率消耗	P_D	238	mW
forward current 正向电流	I_F	70	mA
Peak Forward Current ($t_s \leq 10 \text{ usec}$, $D \leq 1/10$, $T_a=25^{\circ}\text{C}$)	I_{FM}	100	mA
Electrostatic discharge 抗静电	ESD	8000	V
Operating temperature 工作温度	T_{OPR}	-40~+110	$^{\circ}\text{C}$
Storage temperature 储存温度	T_{STG}	-40~+110	$^{\circ}\text{C}$
Maximum junction temperature(1) 最大结温	T_J	125	$^{\circ}\text{C}$
Soldering temperature 焊接温度	Reflow soldering 260°C for 5sec		

Proper current derating must be observed to maintain junction temperature below the Maximum.

Electro optical characteristics($T_a=25^{\circ}\text{C}$)/光电特性

Parameters 参数	Test condition 测试条件	Symbol 符号	Min 最小	Typ 典型	Max 最大	Unit 单位
Forward voltage 正向电压	50mA	VF	2.8	--	3.4	V
Luminous Flux 光通亮	50mA	IF	18	--	26	Lm
Efficacy 光效	50mA		--	--	180	Lm/W
Correlate Color Temp 色温	50mA	CCT	5500	--	6500	K
View Angle 发光角度	50mA	$2\theta_{1/2}$	--	120	--	deg.
Thermal resistance 热阻	50mA	RJ-A	--	42	52	K/W

P28-W003P02Z1S1SA01-AM

Ranks(sorting current=50mA, Ta=25°C)/档位

Item 项目	Rank 档位	Min 最小值	Max 最大值	Unit 单位
Luminous Flux 光通亮	C18	18	20	Lm
	C20	20	22	
	C22	22	24	
	C24	24	26	

Note:

The luminous flux performance is guaranteed within published operating conditions. H-GREAT maintains a tolerance of $\pm 7\%$ on flux measurements.

Item 项目	Rank 档位	Min 最小值	Max 最大值	Unit 单位
Forward voltage 正向电压	C280	2.8	3.0	V
	C300	3.0	3.2	
	C320	3.2	3.4	

Note:

Forward voltage measurement allowance is $\pm 0.05V$.

P28-W003P02Z1S1SA01-AM

Chromaticity Coordinates/色坐标

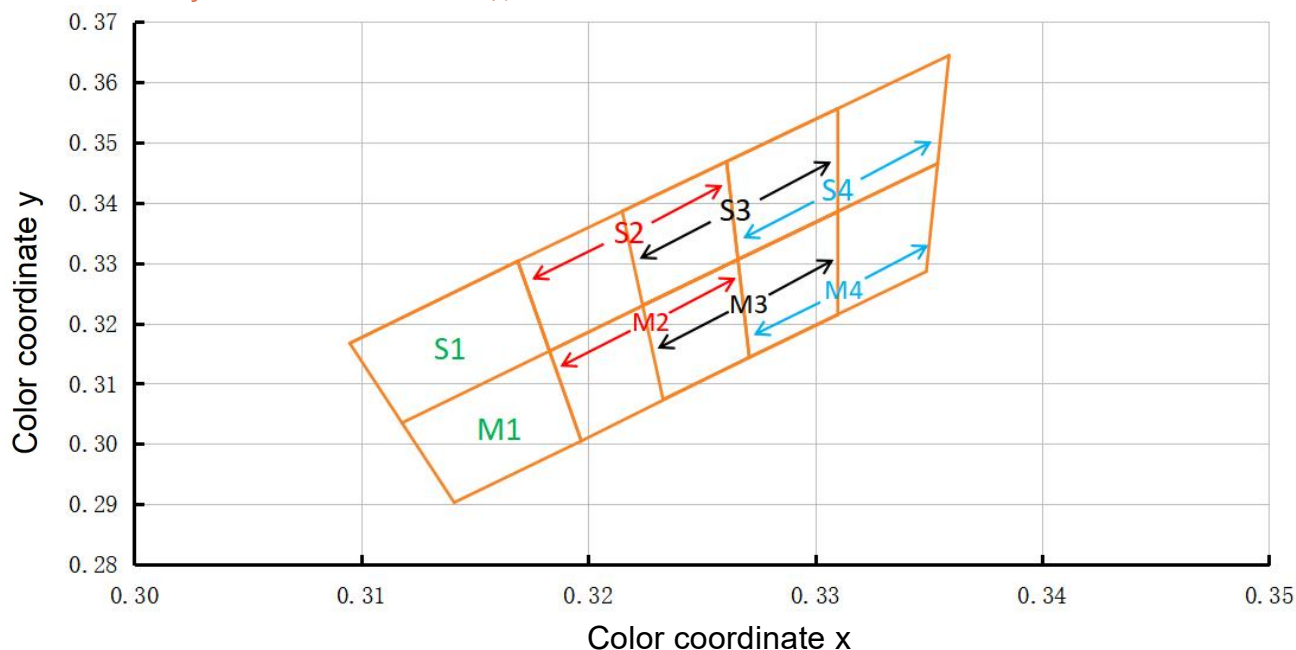

Bin Range of Chromaticity Coordinates Specifications

RANK	x1	y1	x2	y2
	x3	y3	x4	y4
S1	0.3095	0.3167	0.3118	0.3035
	0.3183	0.3154	0.3169	0.3303
S2	0.3169	0.3303	0.3183	0.3154
	0.3266	0.3306	0.3261	0.3468
S3	0.3215	0.3386	0.3224	0.323
	0.331	0.3385	0.331	0.3556
S4	0.3261	0.3468	0.3266	0.3306
	0.3354	0.3465	0.3359	0.3644
M1	0.3118	0.3035	0.3141	0.2903
	0.3197	0.3005	0.3183	0.3154
M2	0.3183	0.3154	0.3197	0.3005
	0.3271	0.3144	0.3266	0.3306
M3	0.3224	0.323	0.3233	0.3074
	0.3310	0.3214	0.331	0.3385
M4	0.3266	0.3306	0.3271	0.3144
	0.3349	0.3286	0.3354	0.3465

Typical electrical optical characteristic curves/典型光电特征曲线

Spectrum Distribution
(@IF = 50 mA; T=25°C)

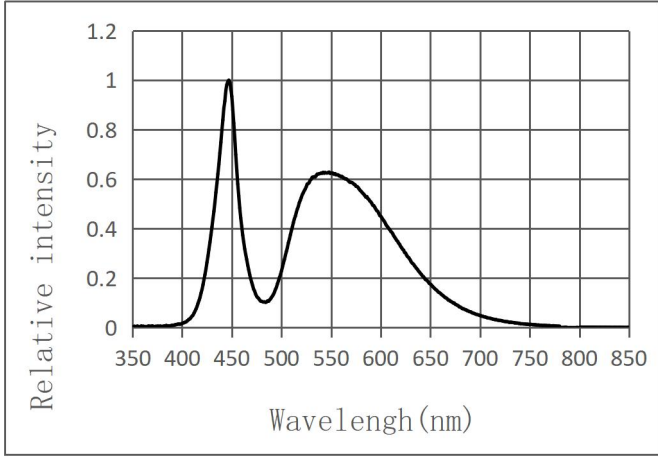

Forward current VS. Forward voltage
(@T = 25°C)

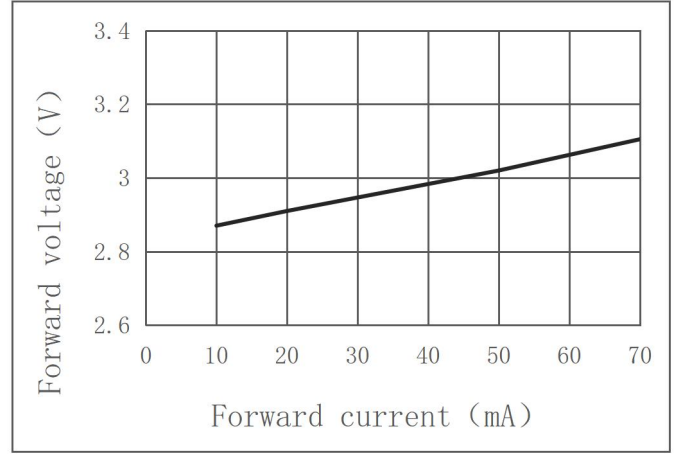

Forward current derating curve
VS.Ambient temperature

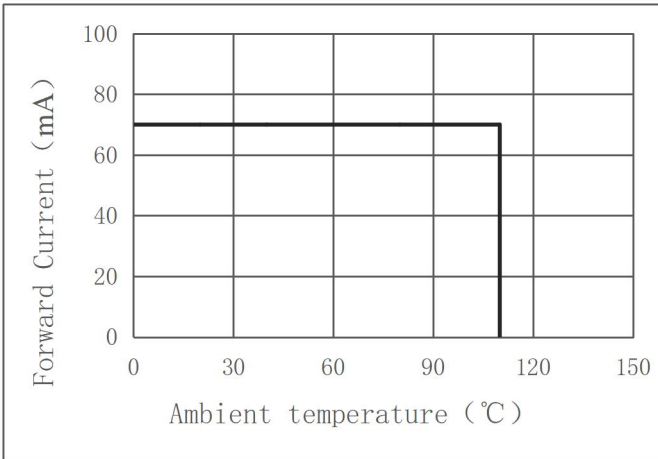

Relative intensity VS. Forward current
(@IF =50 mA; T=25°C)

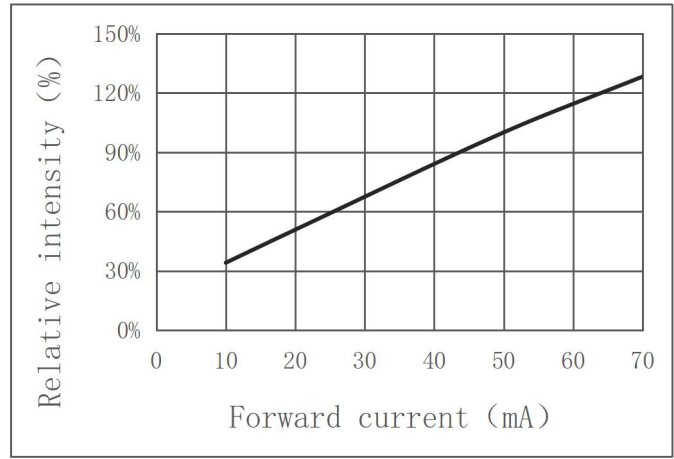

Chromaticity Coordinate Shift
(Δ CIE x, Δ CIE y=f(IF) @ Ts =25°C)

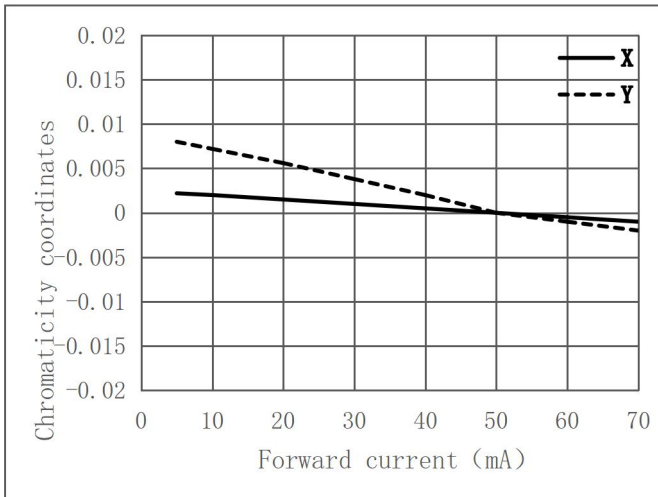

Relative Forward Voltage vs. Junction Temperature
(Δ VF=VF-VF(25°C)=f(Tj) @IF=50mA)

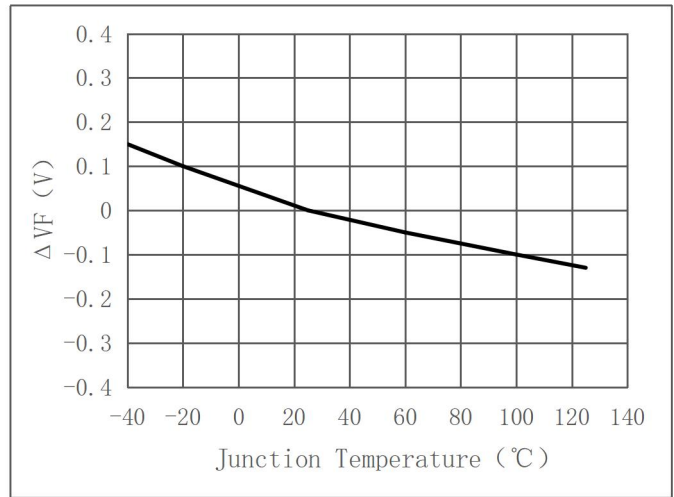

P28-W003P02Z1S1SA01-AM

Relative Luminous Intensity vs. Junction Temperature

$(\Delta I_v = I_v / I_v(25^\circ\text{C}) = f(T_j) \text{ IF} = 50\text{mA})$

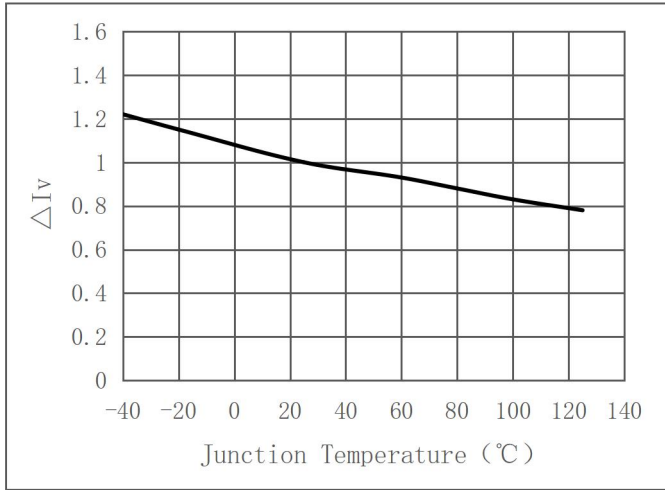

Junction Temperature vs. Color Coordinate Shift

$(\Delta C_x, \Delta C_y = f(T_j); \text{IF} = 50 \text{ mA})$

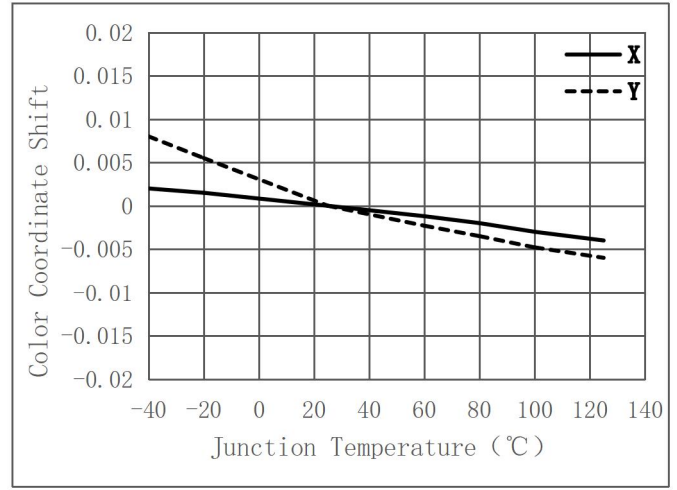

Radiation Intensity vs Radiation Angle

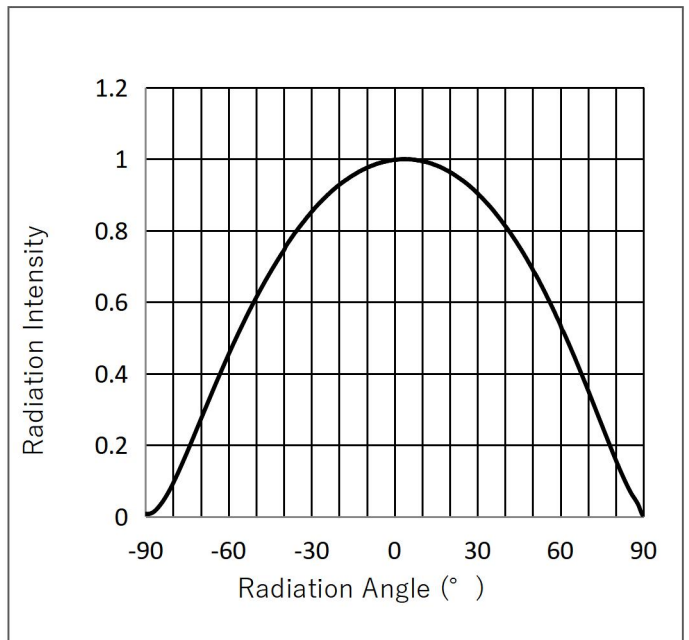
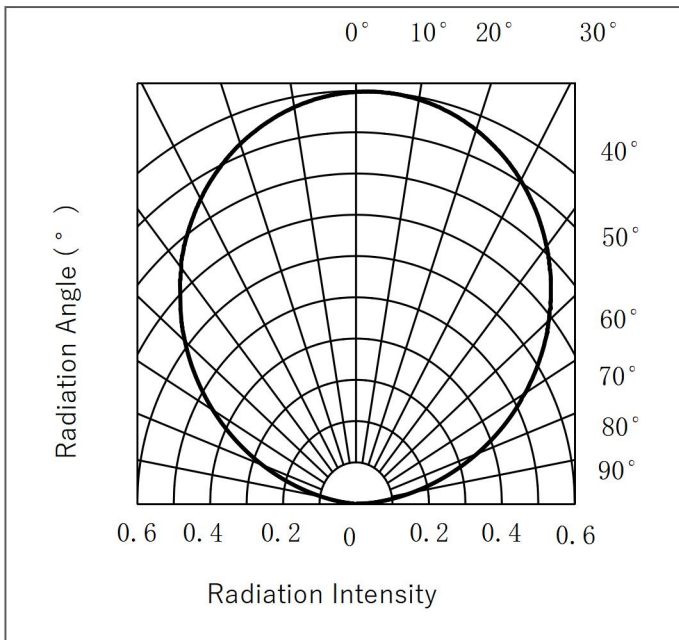

Notes:

1. $2\theta_{1/2}$ is the off axis angle from lamp centerline where the luminous intensity is 1/2 of the peak value.
2. View angle tolerance is $\pm 5^\circ$.

P28-W003P02Z1S1SA01-AM

Package dimensions/产品外观尺寸

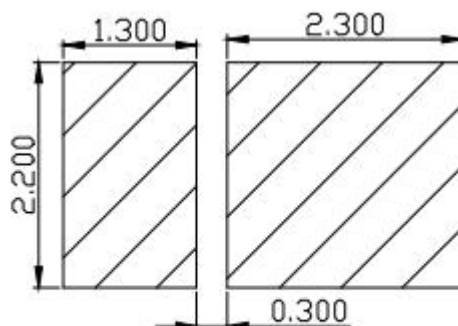
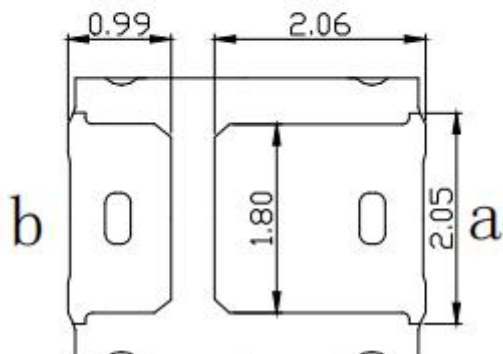
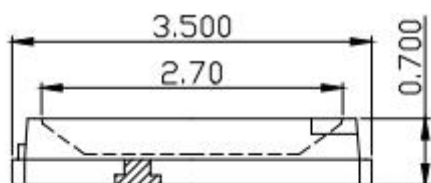
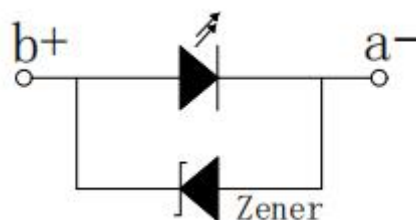
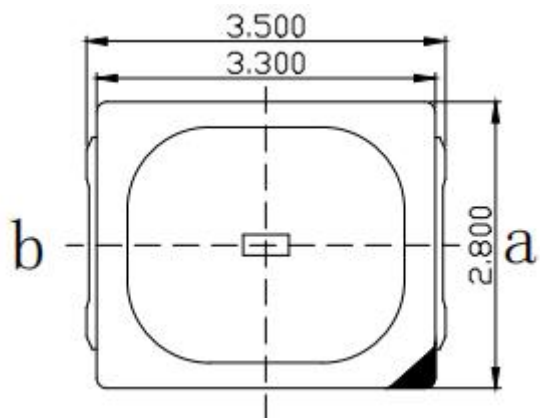

Soldering pad suggested

Notes:

1. All dimensions are measured in mm.
2. Tolerance : ± 0.1 mm
3. Approximate Weight : 18.0 mg

P28-W003P02Z1S1SA01-AM

Packaging specifications/包装规格

Product Labeling/产品标签

Label Explanation/标签解释

CPN: Customers Product Number

P/N: Product Number

Lot NO: Lot Number

VF(V): Forward voltage Bin

IV:Luminous intensity rank

CCT:Color temperature grade

QTY (pcs): Package Quantity

SHENZHEN H-GREAT OPTOELECTRONIC CO.LTD

CPN: XXXXXXX



ROHS

H-20XXXXX-XXXXXXXXXXXXX-X



P/N: XXXXX-XXXX



Lot NO: XXXXXXXXXXXXX



VF(v): XX-XX @XXXmA



IV(lm): XXX-XXX



CCT(K): XXXX-XXXX XXX XX



QTY(pcs): XXXX



XX-XX-XXXXXXXX-XXXX



Carrier Tape Dimensions/卷盘包装

Reel Dimensions/卷盘尺寸

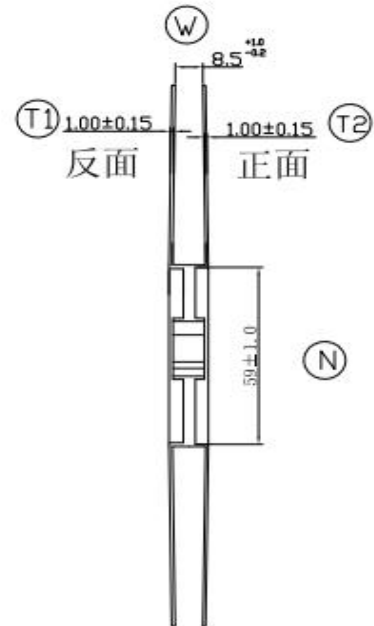
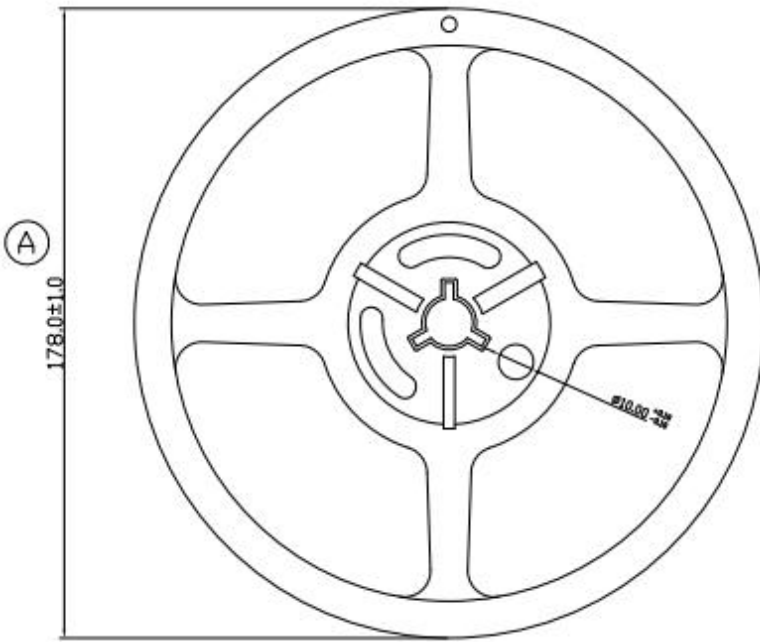

Note/备注:

1. All dimensions are in millimeters;

单位: 毫米

P28-W003P02Z1S1SA01-AM

Tape On Reel Package/载带包装

Carrier Tape Dimensions as the following/载带尺寸

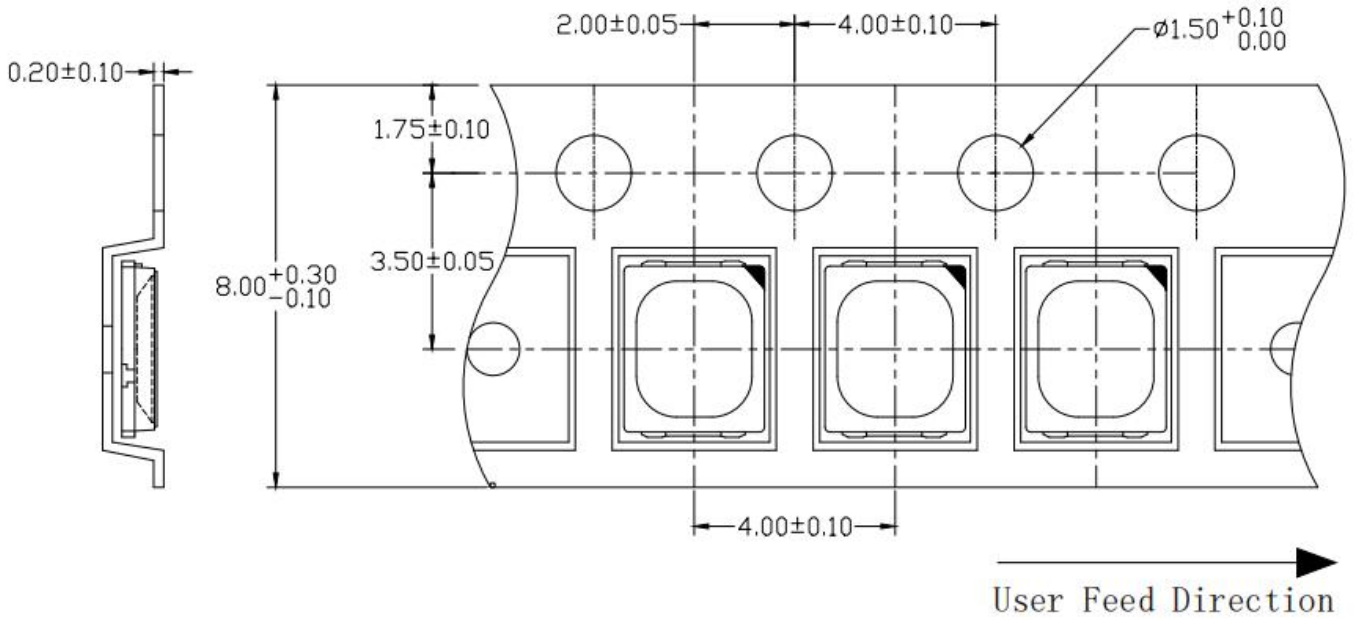

Note/备注:

- (1) The cathode is oriented towards the tape sprocket hole in accordance with data sheet specifications.
根据图表显示，负极朝向载带孔。
- (2) MPQ:4000pcs per reel.
4000颗/每盘。
- (3) 200 empty in front of the tape sprocket, 150 empty in the end of the tape sprocket.
载带前空200颗，后空150颗。

Moisture Resistant Packaging/防潮包装

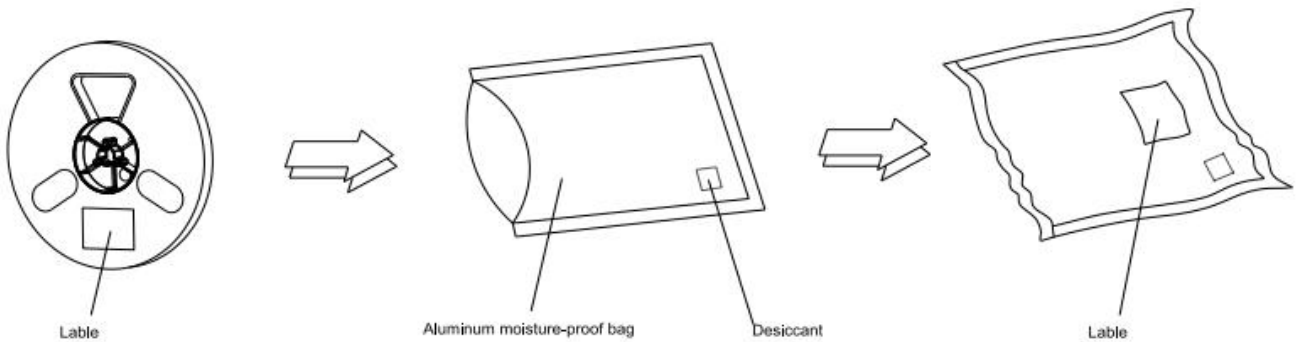

P28-W003P02Z1S1SA01-AM

Soldering Characteristics/焊接工艺

Reflow Soldering Profile/回流曲线

Product complies to MSL Level 3 acc. to JEDEC J-STD-020E

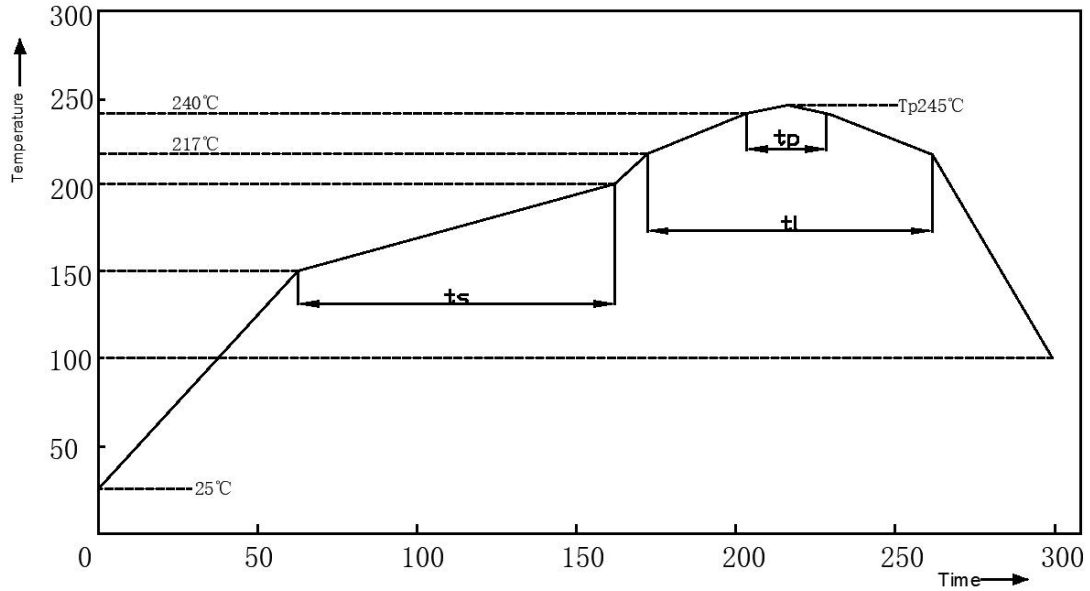

Profile Feature	Pb-Free Assembly	Unit Einheit
Average Ramp-up Rate 25 ° C to 150 ° C	2-3	° C /sec
Preheat Temperature Min.	150	sec
Preheat Temperature Max.	200	sec
Preheat Time	60- 120	sec
Time Maintained Above Temperature	217	° C
Time Maintained Above Time	60-90	sec
Peak Temperature (max.)	260	° C

- c. Reflow soldering should not be done more than twice.
- d. In soldering process, stress on the LEDs during heating should be avoided.
- e. After soldering, do not bend the circuit board.

Cautions/注意事项

1. Moisture-Proof Package/防潮包装

1.1 When moisture is absorbed into the LED package it may vaporize and expand products during soldering. There is a possibility that this may cause exfoliation of the contacts and damage to the optical characteristics of the LEDs. For this reason, the moisture-proof package is used to keep moisture to a minimum in the package.

当水分被吸收到 LED 包装中时，它可能会在焊接过程中蒸发并膨胀产品。这可能会导致触点脱落并损坏 LED 的光学特性。因此，防潮包装需要将包装中的水分保持在最低限度。

2. Current limiting/限流

2.1 A resistor should be used to limit current spikes that can be caused by voltage fluctuations. Otherwise damage could occur.

应使用电阻器限制电压波动引起的电流峰值。否则可能会发生损坏。

3. Iron Soldering/烙铁焊接

3.1 Hand soldering is not recommended for regular production. These guidelines are for rework only. 常规生产不建议手工焊接。此方法仅适用于返工。

3.2 The recommended condition is less than 5s at 260°C.

建议的条件是在 260°C 时小于 5s。

3.3 The time must be shorter for higher temperatures. (+10°C → -1sec)

对于较高的温度，时间必须更短。（+10°C → -1 秒）

3.4 The power dissipation of the soldering iron should be lower than 25W and the surface temperature of the device should be controlled at under 300°C.

烙铁的功耗应低于 25W，器件表面温度应控制在 300°C 以下。

4. Storage Conditions/储存条件

4.1 Before opening the package : The LEDs should be kept at 30°C or less and 90%RH or less. The LEDs should be used within a year. When storing the LEDs, moisture-proof packaging with moisture-absorbent material is recommended.

打开包装前：LED 应保持在 30°C 或以下，相对湿度为 90% 或以下。LED 应在一年内使用。储存 LED 时，建议使用吸湿材进行防潮包装。

4.2 After opening the package: The LEDs should be kept at 30°C or less and 60%RH or less. The LEDs should be soldered within 168 hours (7 days) after opening the package. If unused LEDs remain, they should be stored in moisture-proof packages, such as sealed containers with packages of moisture-absorbent material. It is also recommended to return the LEDs to the original moisture-proof bag and to reseal the moisture-proof bag again.

打开包装后：LED 应保持在 30°C 或以下，相对湿度为 60% 或以下。LED 应在打开包装后 168 小时（7 天）内焊接。如果仍有未使用的 LED 灯珠，则应将其储存在防潮包装中，例如带有吸湿材料包装的密封容器中。也建议将 LED 灯珠放回原来的防潮袋，并再次重新密封防潮袋。

4.3 If the moisture-absorbent material has faded away or the LEDs have exceeded the recommended storage time, baking treatment should be performed using the following conditions. Baking treatment: more than 24 hours at $65 \pm 5^{\circ}\text{C}$

如果吸湿材料褪色或 LED 超过建议的存储时间，则应使用以下条件进行除湿处理。除湿处理：在 $65 \pm 5^{\circ}\text{C}$ 下烘烤超过 24 小时。

4.4 H-Great LED electrode sections are comprised of a silver-plated copper alloy. The silver surface may be affected by environments which contain corrosive gases and so on. Please avoid condition which may cause difficulty environments during soldering operations. It is recommended that the user uses the LEDs as soon as possible.

华皓 LED 灯珠电极部分由镀银铜合金组成。银表面可能受到含有腐蚀性气体等环境的影响。在焊接操作过程中，避免出现可能由环境导致问题的情况。建议用户尽快使用 LED 灯珠。

4.5 Please avoid rapid transitions in ambient temperature, especially in high humidity environments where condensation can occur.

请避免环境温度快速变化，尤其是在可能发生冷凝的高湿度环境中。

5. Handling of Silicone LEDs/硅胶 LED 灯珠处理

5.1 Avoid silicone resin parts especially with sharp tools such as tweezers.

避免使用锋利工具，尤其是使用镊子等接触硅胶部分。

5.2 Avoid leaving fingerprints on silicone part.

避免在硅胶零件上留下指纹。

6. Usage/用途

6.1 Do not exceed the values given in this specification.

不要超出本规范中给出的使用条件。

P28-W003P02Z1S1SA01-AM

Revision History

Versions	Description	Release Date
A0	Standard data sheet	2023/08/10
A1	Typical electrical optical characteristic curves	2024/04/02
A2	Update thermal resistance data	2024/05/15
A3	newly increased coordinate chart	2024/07/30
A4	Update brightness parameter	2024/08/30