

PDFN5060 Plastic-Encapsulate MOSFETS

Features

- $V_{DS}=30V$
- $I_D=35A$
- $R_{DS(on)}@V_{GS}=10V < 8m\Omega$
- $R_{DS(on)}@V_{GS}=4.5V < 11m\Omega$
- Low Gate Charge and R_{dson}
- Advanced Split Gate Trench Technology
- Fast Switching Speedze

Drain-source Voltage

30 V

Drain Current

35 Ampere

Applications

- Power switching application
- DC-DC Converters

Mechanical Data

- Case: PDFN5060
Molding compound meets UL 94V-0 flammability rating, RoHS-compliant,halogen-free
- Terminals: Solder plated, solderable per MIL-STD-750,Method 2026

Function Diagram

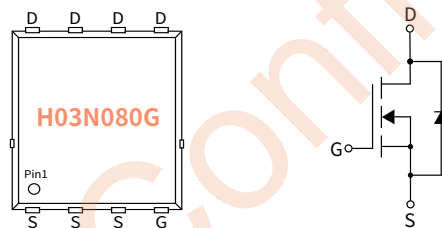

Ordering Information

PACKAGE	PACKAGE CODE	UNIT WEIGHT(g)	REEL(pcs)	BOX(pcs)	CARTON(pcs)	DELIVERY MODE
PDFN5060	R3	0.09	5000	10000	80000	13"

Maximum Ratings (Ta=25°C Unless otherwise specified)

PARAMETER	SYMBOL	UNIT	VALUE
Drain-source Voltage	V_{DS}	V	30
Gate-source Voltage	V_{GS}	V	± 20
Drain Current	I_D	A	35
Pulsed Drain Current ⁽¹⁾	I_{DM}	A	140
Total Power Dissipation	P_D	W	28
Single pulse avalanche energy ⁽²⁾	EAS	mJ	19
Junction temperature	T_J	°C	-55 ~+150
Storage temperature	T_{stg}	°C	-55 ~+150
Thermal Resistance Junction-to-Case	$R_{\theta JC}$	°C / W	4.5

● Static Parameter Characteristics (T_j=25°C Unless otherwise specified)

PARAMETER	SYMBOL	Condition	UNIT	Min	Typ	Max
Drain-Source Breakdown Voltage	BV _{DSS}	V _{GS} = 0V, I _D =250μA	V	30	—	—
Zero Gate Voltage Drain Current	I _{DSS}	V _{DS} =30V, V _{GS} =0V	μA	—	—	1.0
Gate-Body Leakage Current	I _{GSS}	V _{GS} = ±20V, V _{DS} =0V	nA	—	—	±100
Gate Threshold Voltage	V _{GS(th)}	V _{DS} = V _{GS} , I _D =250μA	V	1.2	1.7	2.2
Static Drain-Source On-Resistance ⁽³⁾	R _{DS(ON)}	V _{GS} = 10V, I _D =12A	mΩ	—	6	8
	R _{DS(ON)}	V _{GS} = 4.5V, I _D =12A		—	9.4	11

● Dynamic Parameters

PARAMETER	SYMBOL	Condition	UNIT	Min	Typ	Max
Input Capacitance	C _{iss}	V _{DS} =15V, V _{GS} =0V, f=1MHZ	pF	—	692	—
Output Capacitance	C _{oss}			—	388	—
Reverse Transfer Capacitance	C _{rss}			—	62	—

● Switching Parameters

PARAMETER	SYMBOL	Condition	UNIT	Min	Typ	Max
Turn-on Delay Time	t _{D(on)}	V _{GS} =10V, V _{DD} =15V, I _D =12A, R _{GEN} =2Ω	nS	—	7	—
Turn-on Rise Time	t _r		nS	—	18.8	—
Turn-off Delay Time	t _{D(off)}		nS	—	19.5	—
Turn-off fall Time	t _f		nS	—	3.4	—
Total Gate Charge	Q _g	V _{DS} =15V, I _D =12A V _{GS} =10V	nC	—	15	—
Gate-Source Charge	Q _{gs}		nC	—	2.2	—
Gate-Drain Charge	Q _{gd}		nC	—	3.1	—

● Driian-Source Diode Characteristics

PARAMETER	SYMBOL	Condition	UNIT	Min	Typ	Max
Diode Forward Voltage	V _{SD}	I _S =35A, V _{GS} =0V	V	—	—	1.2
Maximum Body-Diode Continuous Current	I _S	—	A	—	—	35
Reverse Recovery Time	T _{rr}	I _S =35A, di/dt=100A/us, T _J =25°C	nS	—	11	—
Reverse Recovery Charge	Q _{rr}		nC	—	18	—

Note:

(1) Repetitive Rating: Pulse width limited by maximum junction temperature.

(2) EAS condition : T_j=25°C, V_{DD}=15V, V_G=10V, L=0.1mH, I_{AS}=19.5A, R_g=25Ω.

(3) Pulse Test: Pulse Width ≤ 300μs, Duty Cycle ≤ 2%.

● Ratings And Characteristics Curves (Ta=25°C Unless otherwise specified)

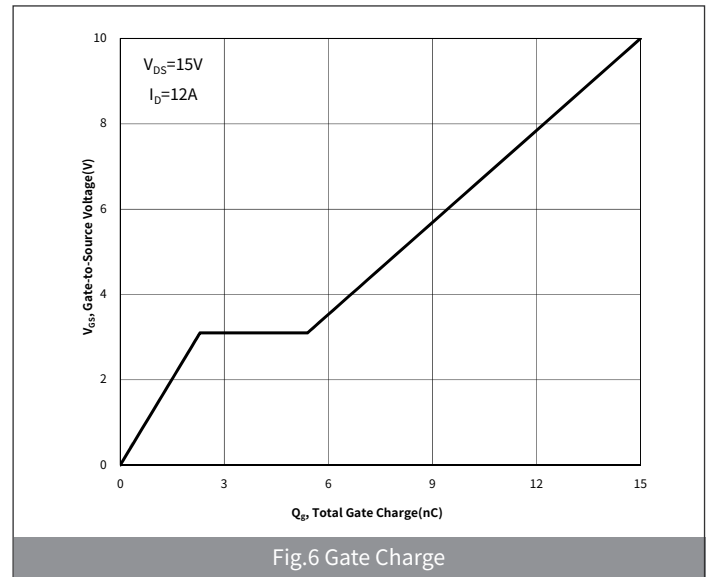
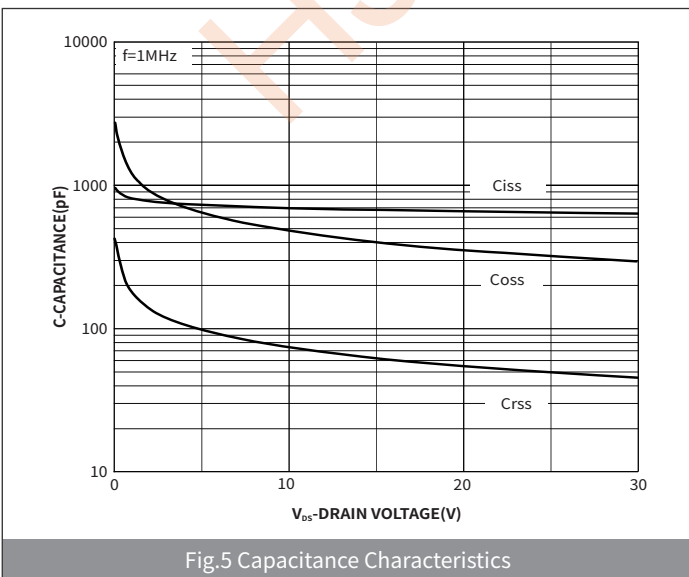
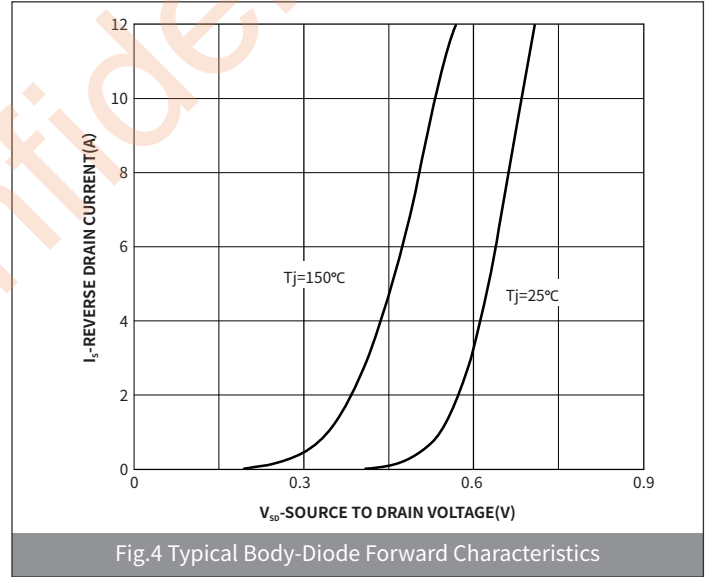
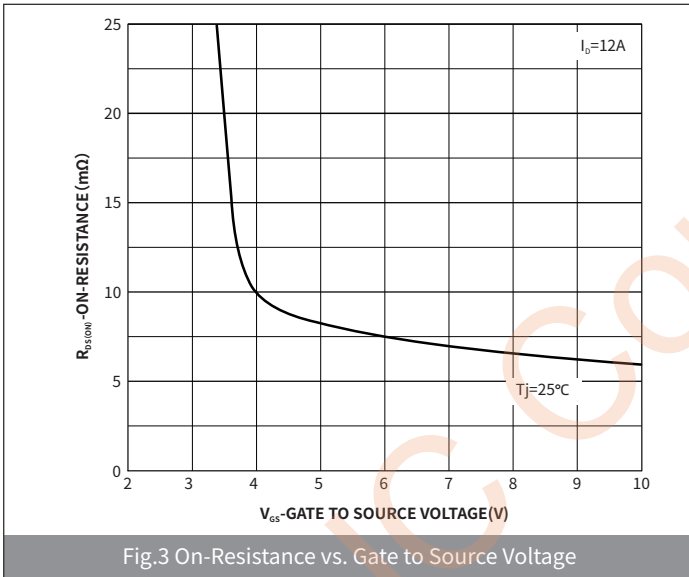
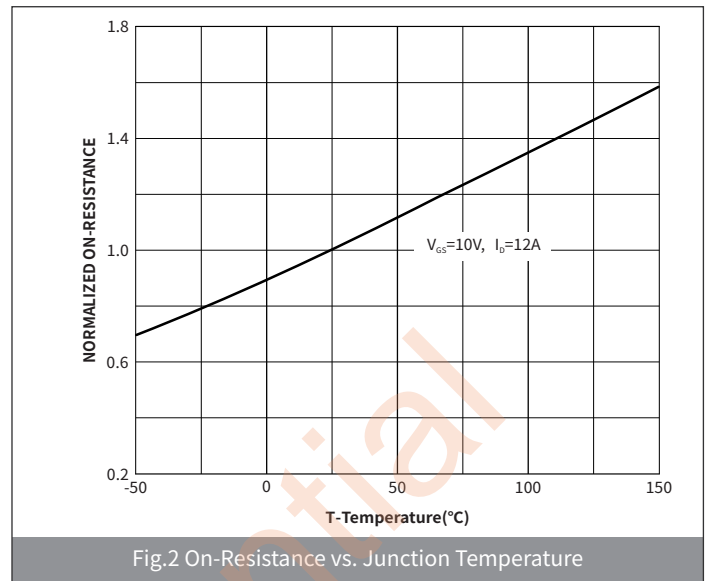
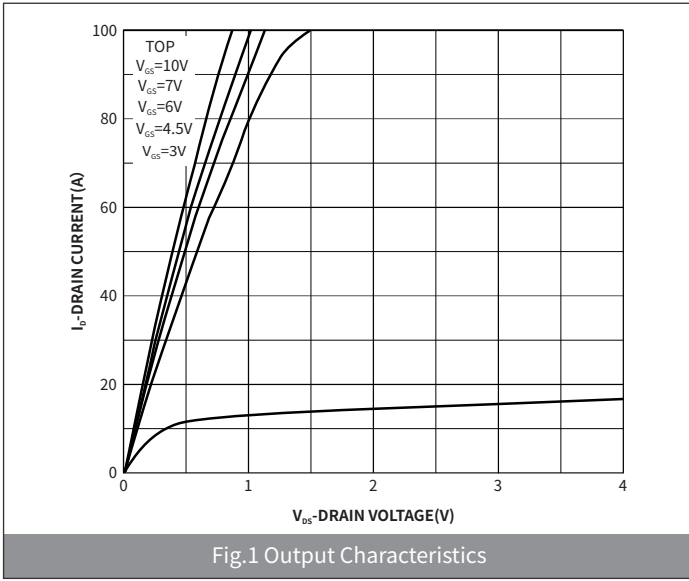

● Ratings And Characteristics Curves (Ta=25°C Unless otherwise specified)

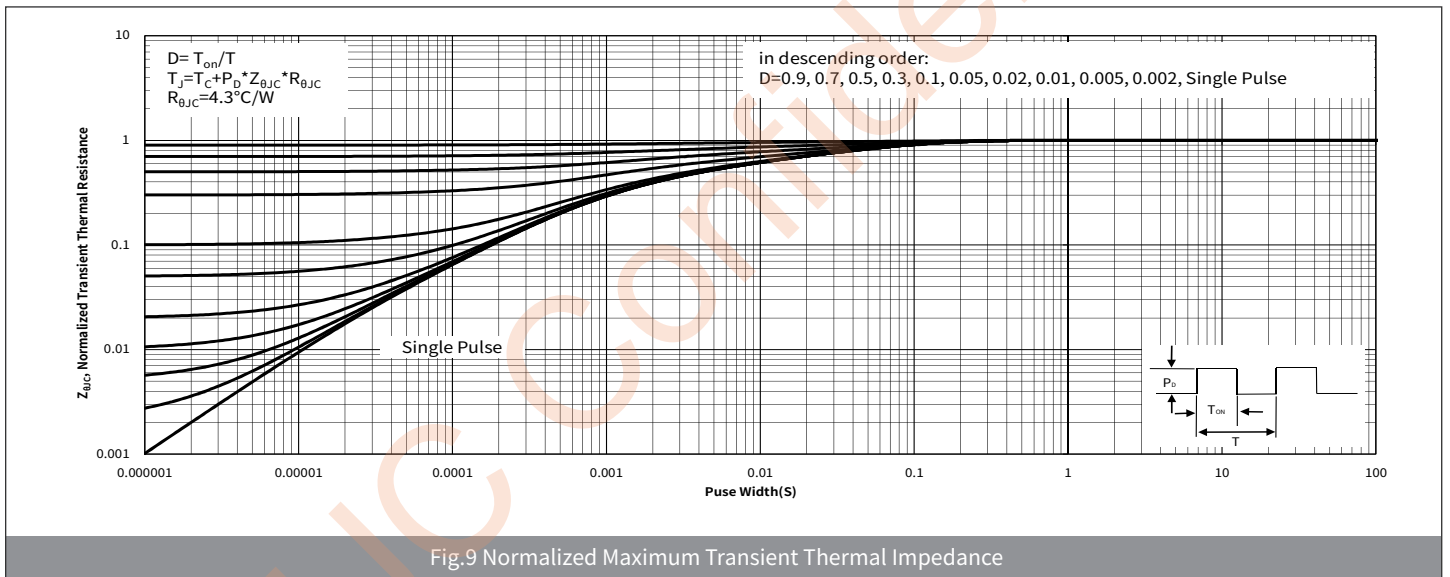
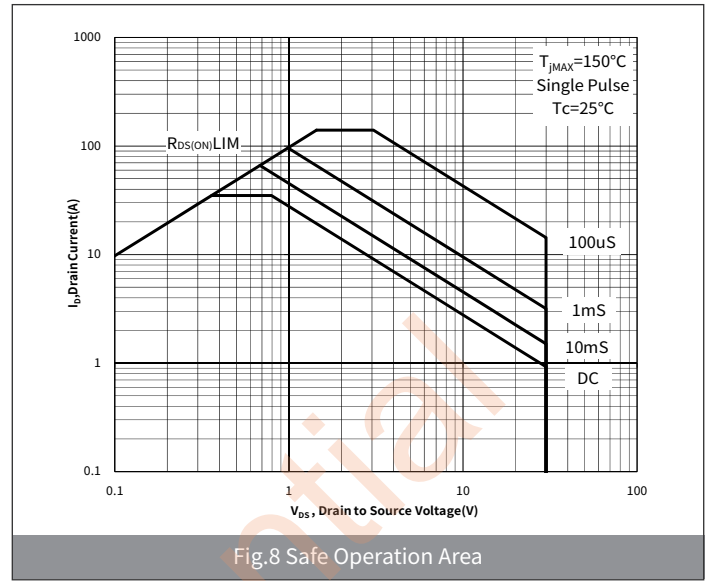
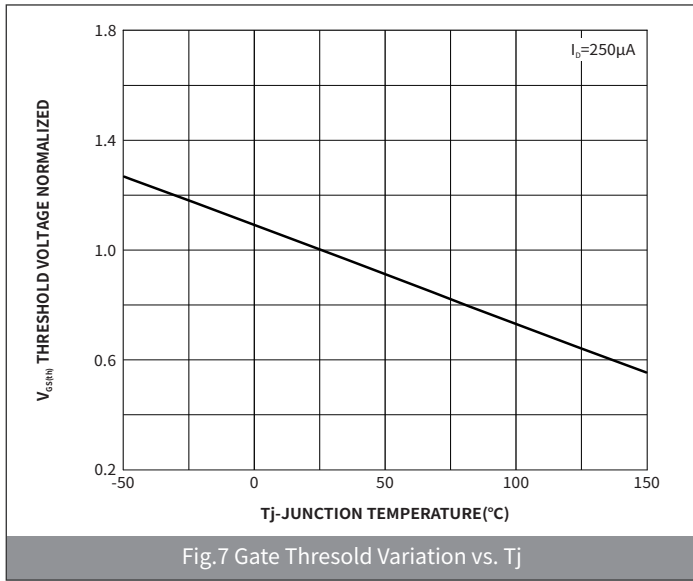

● Package Outline Dimensions (PDFN5060)

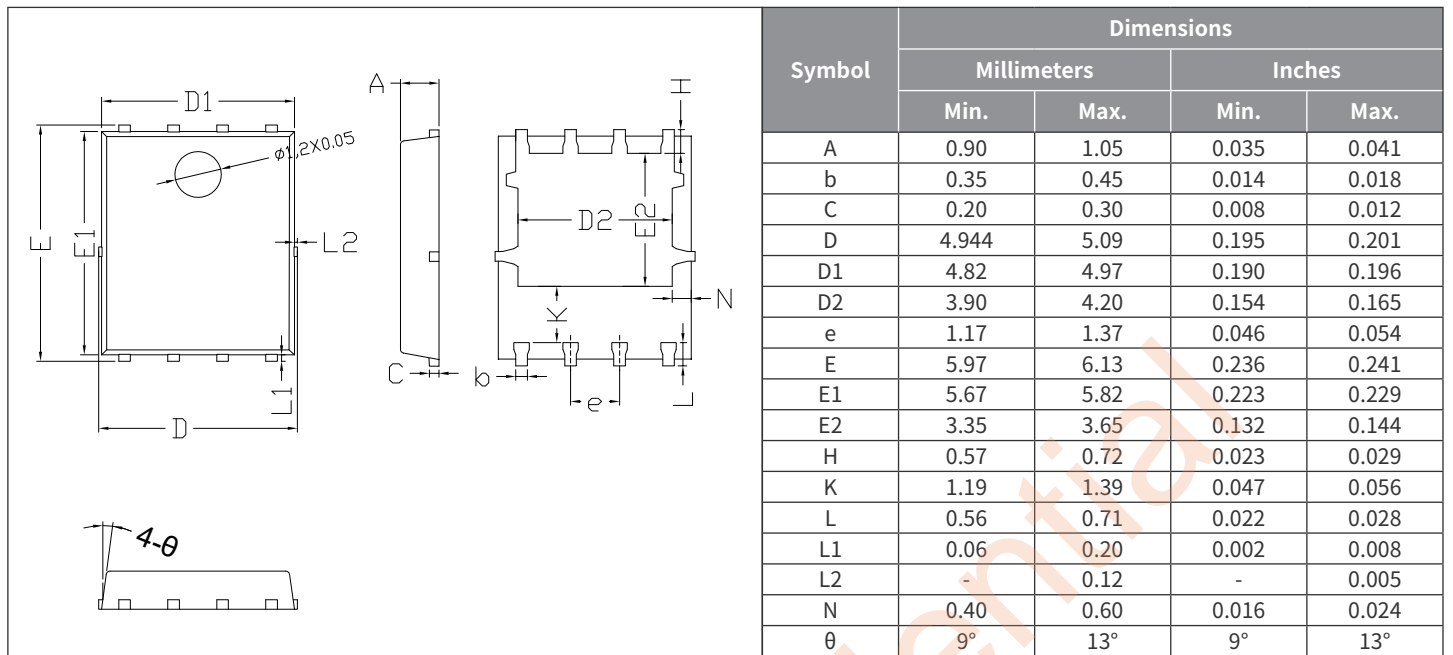

● Suggested Pad Layout

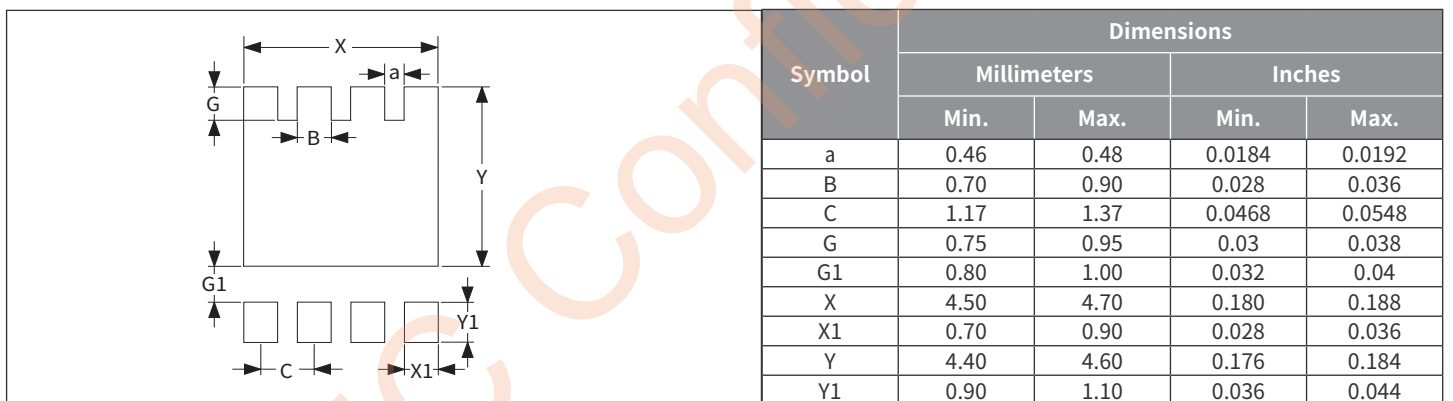

1. Gate Charge Test Circuit & Waveforms

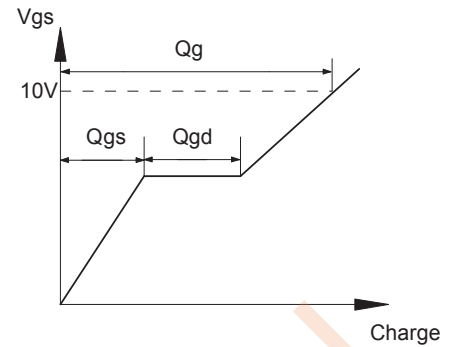
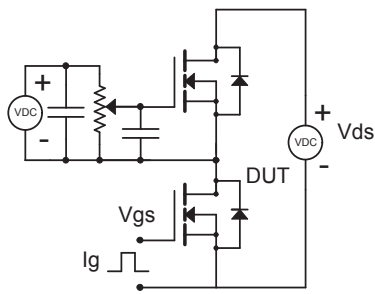

2. Resistive Switching Test Circuit & Waveforms

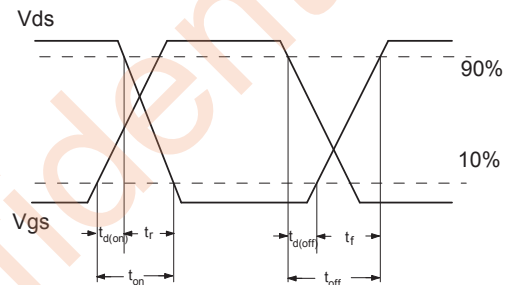
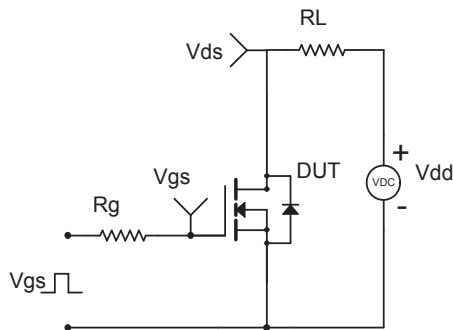

3. Unclamped Inductive Switching (UIS) Test Circuit & Waveforms

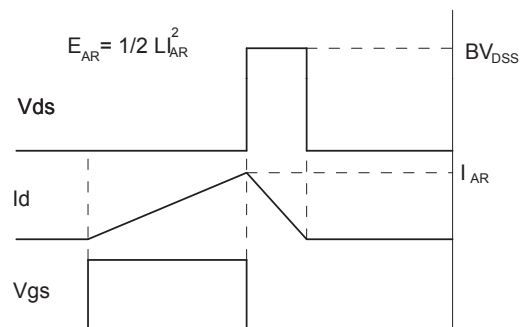
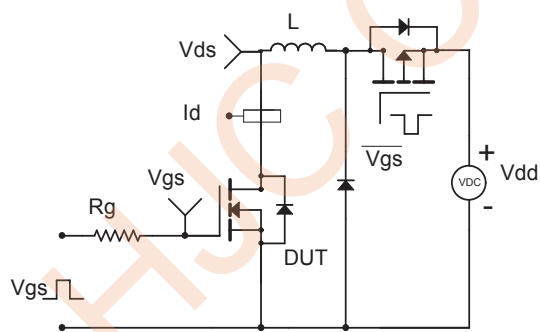

4. Diode Recovery Test Circuit & Waveforms

