

High- and Low-Side Voltage Output, Zero-Drift Current Sense Amplifiers

Features

- High- and Low-Side Measurement
- Wide Common-Mode Range:
-0.3V to +16V
- Power Supply Range: 2.7V to 5.5V
- Low Quiescent Current: 50µA typical
- Low Offset Voltage: ±50µV max
- Low Offset Drift: 0.5µV/°C
- Low Gain Error: 2% max
- Low Gain Error Drift: 10 ppm/°C max
- Rail-to-Rail Output
- Industrial Operation Range:
-40°C to 125°C
- Small Packaging: SOT23-5/MSOP8
- Choice of Gains:
 - 20V/V (COS180A1)
 - 50V/V (COS180A2)
 - 100V/V (COS180A3)
 - 200V/V (COS180A4)

Applications

- Current Sensing
- Battery Charging and Discharging
- Overcurrent Protection
- Motor Control

Rev1.0

Copyright©2018 Cosine Nanoelectronics Inc. All rights reserved
The Information provided here is believed to be accurate and reliable. Cosine Nanoelectronics assumes no reliability for inaccuracies and omissions. Specifications described and contained here are subjected to change without notice on the purpose of improving the design and performance. All of this information described herein should not be implied or granted for any third party

General Description

The COS180 (single) and COS2180 (dual) are voltage output, current sense amplifiers (also called current shunt monitors) which can measure voltage across shunts at common-mode voltages from -0.3V to +16V, independent of supply voltage. The low offset of the zero-drift architecture enables current sensing across the shunt with maximum voltage drop as low as 10mV full-scale.

These devices can operate from a single +2.7V to +5.5 V power supply, drawing a typical 50µA of supply current, and are specified over the extended operating temperature range (-40°C to +125°C). The COSx180 family are commonly used for over-current protection, precision-current measurement for system optimization or in closed-loop feedback circuits.

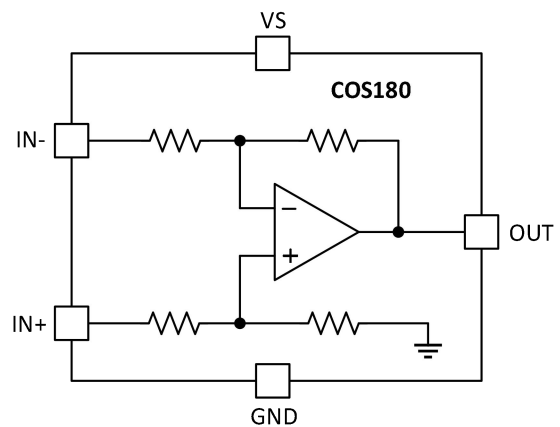

Simplified Schematic

1 Pin Configuration and Functions

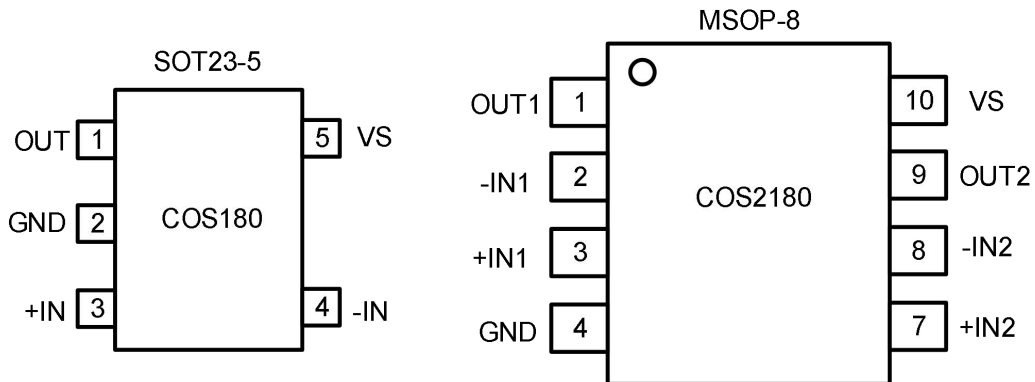

Figure 1 Pin Diagram

Pin Description

Pin	Name	I/O	Description
1	OUT	Analog output	Output voltage
2	GND	Analog	Ground
3	+IN	Analog input	Connect to supply side of shunt resistor
4	-IN	Analog input	Connect to load side of shunt resistor
5	VS	Analog	Power supply, +2.7V to +5.5V

2 Package and Ordering Information

Channel	Gain (V/V)	Model	Order Number	Package	Package Option	Marking
1	20	COS180A1	COS180A1	SOT23-5	Tape and Reel, 3000	C180A1
	50	COS180A2	COS180A2	SOT23-5	Tape and Reel, 3000	C180A2
	100	COS180A3	COS180A3	SOT23-5	Tape and Reel, 3000	C180A3
	200	COS180A4	COS2180A4	SOT23-5	Tape and Reel, 3000	C180A4
2	20	COS2180A1	COS2180A1	MSOP-8	Tape and Reel, 3000	COS2180A1
	50	COS2180A2	COS2180A2	MSOP-8	Tape and Reel, 3000	COS2180A2
	100	COS2180A3	COS2180A3	MSOP-8	Tape and Reel, 3000	COS2180A3
	200	COS2180A4	COS2180A4	MSOP-8	Tape and Reel, 3000	COS2180A4

3 Product Specification

3.1 Absolute Maximum Ratings (1)

Parameter	Min	Max	Unit
Supply Voltage, V_s		+20	V
Differential Analog Inputs, $(V_{IN+}) - (V_{IN-})$	-20	+20	V
Common Mode Analog Inputs, V_{IN+}, V_{IN-}	GND-0.3	+20	V
Output Voltage, V_{OUT}	GND-0.3	$V_s+0.3$	V
Maximum Output Current, I_{OUT}		8	mA
Maximum Junction Temperature, $T_{J(max)}$		+150	°C
Storage temperature, T_{STG}	-55	+150	°C

(1) Stresses exceeding the absolute maximum ratings may damage the device. The device may not function or be operable above the recommended operating conditions and stressing the parts to these levels is not recommended. In addition, extended exposure to stresses above the recommended operating conditions may affect device reliability. The absolute maximum ratings are stress ratings only.

3.2 Thermal Data

Parameter	Rating	Unit
Package Thermal Resistance, $R_{\theta JA}$ (Junction-to-Ambient)	190 (SOT23-5) 206 (MSOP8)	°C/W

3.3 Recommended Operating Conditions

Parameter	Min.	Typ.	Max.	Unit
Common-mode Input Voltage, V_{CM}	-0.3	12	16	V
Supply Voltage, V_s	2.7	5	5.5	V
Operating Ambient Temperature, T_A	-40		+125	°C

3.4 Electrical Characteristics

(Typical values are tested at $T_A=25^\circ\text{C}$, $V_S=5\text{V}$, $V_{IN+}=12\text{V}$, and $V_{SENSE}=V_{IN+} - V_{IN-}$, unless otherwise noted)

Parameter	Symbol	Conditions	Min.	Typ.	Max.	Unit
INPUT						
Common-mode Input Range	V_{CM}	$V_{SENSE}=10\text{mV}$ $T_A = -40^\circ\text{C to } +125^\circ\text{C}$	-0.3		16	V
Common-mode Rejection Ratio	CMRR	$V_{IN+} = 0\text{V to } +16\text{V}$, $V_{SENSE} = 0\text{mV}$	80	100		dB
Offset Voltage, RTI (input referred)	V_{OS}	$V_{SENSE} = 0\text{mV}$		± 5	± 50	μV
Vos Temperature Drift	$\Delta V_{OS}/\Delta T$	$V_{SENSE} = 0\text{mV}$ $T_A = -40^\circ\text{C to } +125^\circ\text{C}$		0.1	0.5	$\mu\text{V}/^\circ\text{C}$
Vos vs Power Supply Ratio	PSRR	$V_S = 3.0\text{V to } +16\text{V}$, $V_{SENSE}=10\text{mV}$		± 0.2	± 20	$\mu\text{V/V}$
Input Bias Current	I_{IB}	$V_{SENSE} = 0\text{mV}$		12	30	μA
Input Offset Current	I_{IO}	$V_{SENSE} = 0\text{mV}$		± 0.1		μA
OUTPUT						
Gain	G	COS180A1		20		V/V
		COS180A2		50		
		COS180A3		100		
		COS180A4		200		
Gain Error	E_G	$V_{SENSE} = -5\text{mV to } 5\text{mV}$ $T_A = -40^\circ\text{C to } +125^\circ\text{C}$		± 0.2	± 2	%
Gain Error vs Temperature		$T_A = -40^\circ\text{C to } +125^\circ\text{C}$		3	20	ppm/ $^\circ\text{C}$
Non-linearity Error		$V_{SENSE} = -5\text{mV to } 5\text{mV}$		± 0.01		%
Maximum Capacitive Load	C_L	No sustained oscillation		0.5		nF
Swing to V_S Power Supply Rail	V_{OH}	$R_{LOAD}=10\text{k}\Omega$ to GND $T_A = -40^\circ\text{C to } +125^\circ\text{C}$		$V_S-0.02$	$V_S-0.2$	V
Swing to GND	V_{OL}			$V_{GND}+0.002$	$V_{GND}+0.05$	V

FREQUENCY RESPONSE						
Bandwidth	BW	A1 device, C _{LOAD} =10pF		67		kHz
		A2 device, C _{LOAD} =10pF		42		
		A3 device, C _{LOAD} =10pF		30		
		A4 device, C _{LOAD} =10pF		14		
Slew Rate	SR			0.55		V/μs
NOISE						
Input Referred Voltage Noise	e _n	f=1kHz		45		nV/ √Hz
POWER SUPPLY						
Operating Voltage Range	V _s		2.7	-	5.5	V
Quiescent Current	I _Q	COS180		50	100	μA
		COS2180		100	200	μA

4 Application Information

The COS180, COS2180 current-sense amplifiers provide the fully differential input necessary to get accurate shunt connections, while also providing a built-in gain network with precision difficult to obtain with external resistors. The COSx180 series of devices can be configured for both low-side and high-side current sensing. While at times the application requires low – side sensing, only high–side sensing can detect a short from the positive supply line to ground. Furthermore, high–side sensing avoids adding resistance to the ground path of the load being measured. The application below focus primarily on high–side current sensing.

Figure 2 shows the basic connections of the COS180. The device amplify the voltage developed across a current-sensing resistor as current flows through the resistor to the load or ground. When the input signal increases, the output voltage at the OUT pin increases. For the best measurement accuracy, connect the input pins (IN+ and IN-) as close as possible to the shunt resistor to minimize any resistance in series with the shunt resistor.

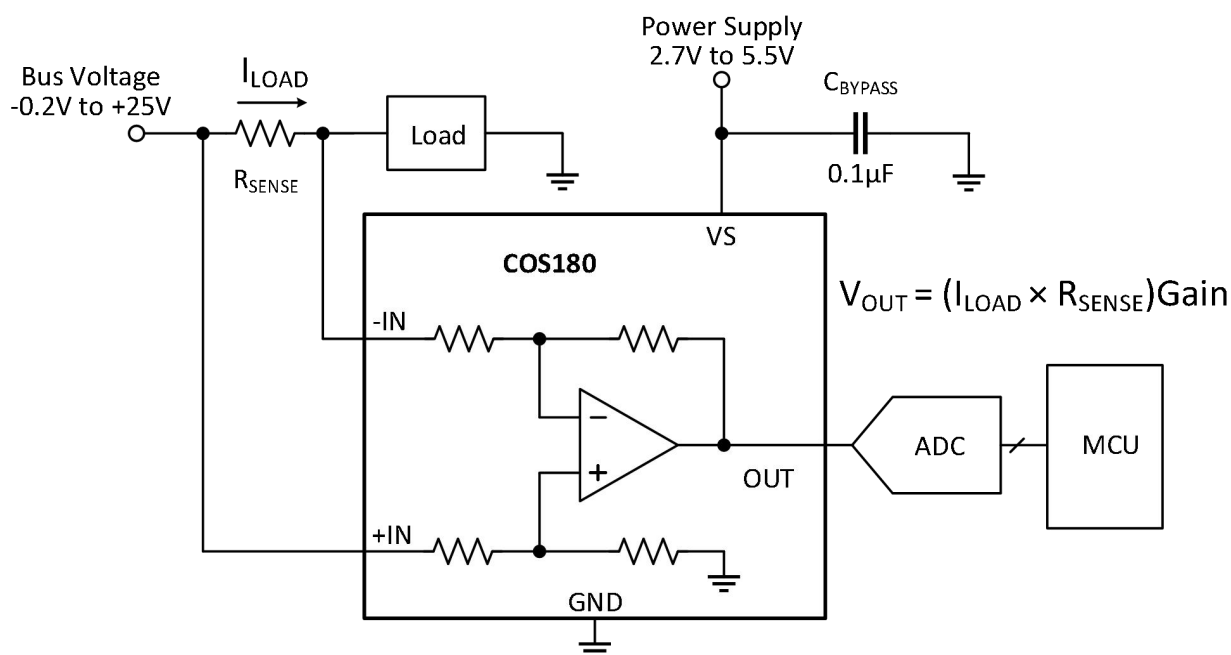

Figure 2 Typical Application Schematic

The desired accuracy of the current measurement determines the current-sensing resistor precision and value. The larger the resistor value, the more accurate the measurement possible, but a large resistor value also results in greater power loss. Therefore, using current-sense resistors larger than a few ohms is generally not recommended.

A typical non-zero-drift current shunt monitors typically require a full-scale range of 100 mV. The COSx180 zero-drift series gives equivalent accuracy at a full-scale range on the order of 10 mV. This accuracy reduces shunt dissipation by an order of magnitude with many additional benefits.

The input circuitry of the COSx180 can accurately measure beyond the power-supply voltage, V+. For example, the V+ power supply can be 5 V, whereas the load power-supply voltage can be as high as +16V. However, the output voltage range of the OUT pin is limited by the voltages on the power-supply pin. Note also that the COSx180 can withstand the full input signal range up to +16V at the input pins, regardless of whether the device has power applied or not.

A power-supply bypass capacitor of at least 0.1 µF is required for proper operation. Applications with noisy or high-impedance power supplies may require additional decoupling capacitors to reject power-supply noise. Connect bypass capacitors as close as possible to the device pins.

5 Package Information

5.1 SOT23-5 (Package Outline Dimensions)

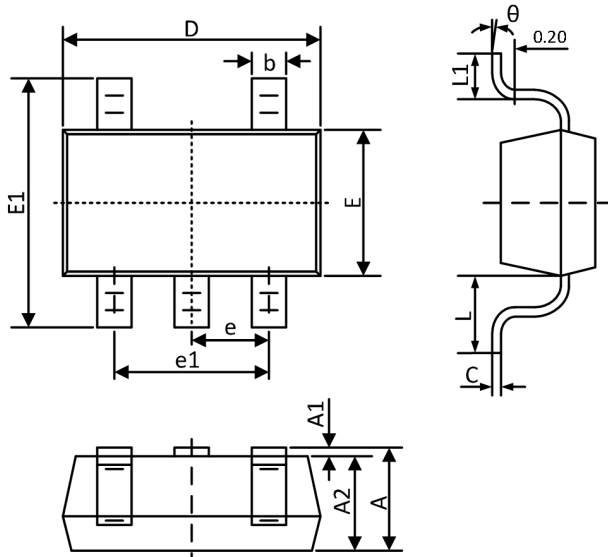

Symbol	Dimensions In Millimeters		Dimensions In Inches	
	MIN	MAX	MIN	MAX
A	1.050	1.250	0.041	0.049
A1	0.000	0.100	0.000	0.004
A2	1.050	1.150	0.041	0.045
b	0.300	0.400	0.012	0.016
c	0.100	0.200	0.004	0.008
D	2.820	3.020	0.111	0.119
E	1.500	1.700	0.059	0.067
E1	2.650	2.950	0.104	0.116
e	0.950TYP		0.037TYP	
e1	1.800	2.000	0.071	0.079
L	0.700REF		0.028REF	
L1	0.300	0.600	0.012	0.024
θ	0°	8°	0°	8°

5.2 MSOP8 (Package Outline Dimensions)

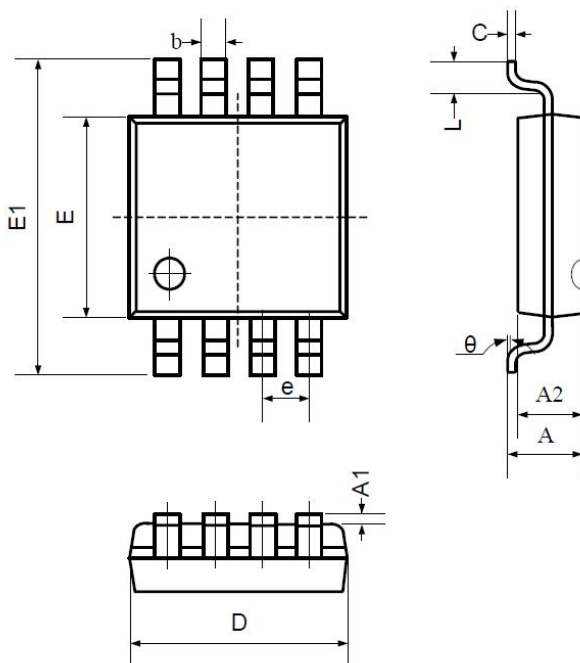

Symbol	Dimensions In Millimeters		Dimensions In Inches	
	Min	Max	Min	Max
A	0.800	1.200	0.031	0.047
A1	0.000	0.200	0.000	0.008
A2	0.760	0.970	0.030	0.038
b	0.30 TYP		0.012 TYP	
c	0.15 TYP		0.006 TYP	
D	2.900	3.100	0.114	0.122
e	0.65 TYP		0.026 TYP	
E	2.900	3.100	0.114	0.122
E1	4.700	5.100	0.185	0.201
L	0.410	0.650	0.016	0.026
θ	0°	6°	0°	6°