



钰地半导体  
Tudi Semiconductor

## Product Specification

TUDI-SN65HVD55/54/53

5V High-Output Full-Duplex RS-485 Driver and Receiver

网址 [www.sztdbdt.com](http://www.sztdbdt.com) 🔍

**用芯智造 · 卓越品质**

**semiconductor device  
manufacturer**

- Design
- research and development
- production
- and sales



## Features

- 1/8 unit load option available (up to 256 nodes on the bus)
- Bus pin ESD protection exceeds 1 kV HBM
- 65HVD55 1Mbps signaling rate
- 65HVD54 5Mbps signaling rate
- 65HVD53 18Mbps signaling rate
- Low current sleep mode <math>< 1\mu\text{A}</math>
- No interference power up and power down bus I/O
- Bus idle, open, and short circuit fault protection
- Designed for RS-422 and RS-485 networks

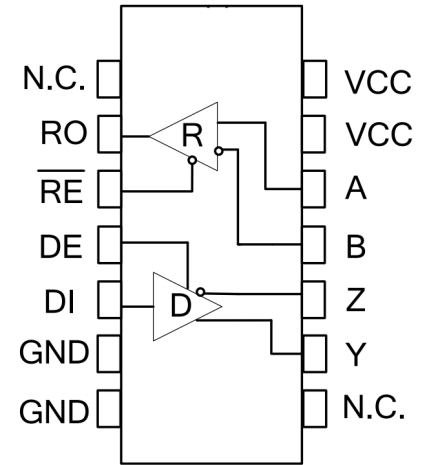

Figure 1 Pin diagram

## Description

The SN65HVD5X devices are three-state differential line drivers and differential input line receivers with 5V power supplies. Each and receiver has separate input and output pins for full-duplex bus communication designs. They are designed for balanced transmission lines and are interoperable with devices compliant with the ANSIIA/EIA-485A, TIA/EIA-422-B standards.

The SN65HVD53, SN65H54, and SN65HVD55 all feature a high-level-active driver enable input and a low-level-active receiver enable input.

All devices over the temperature range of  $-40^{\circ}\text{C}$  to  $85^{\circ}\text{C}$ .

Compared to typical RS-485 drivers, the high output characteristics of the SN5HVD5x provide higher noise immunity. The additional noise immunity allows for applications in long cables and harsh noise environments.

## Applications

- Utility meter
- Backbone to backbone interconnection
- DTE/DCE interface
- Industrial, process and building automation
- Point of sale ( POS ) terminal and network



## Pin description

Pin number	Pin name	Pin function
1	NC	No internal connection, no need to connect;
2	RO	Receiver output. When /RE is low, if $A-B \geq -10\text{mV}$ , RO output is high; if $AB \leq -200\text{mV}$ , RO output is low.
3	/RE	Receiver output enable control. When /RE is low, the receiver output is enabled and RO is valid; when /RE is high, the receiver is disabled and RO is high impedance; /RE is high and DE is low, the device enters low-power off mode.
4	DE	Driver output enable control. The driver output is active when DE is high, and the output is high-impedance when DE is low; / is high and DE is low, the device enters low-power shutdown mode.
5	DI	DI driver input. A low on DI with DE high causes the driver's A output to be low and B output to be high; a high DI will cause the A output to be high and the B output to be low.
6	GND	grounding
7	GND	grounding
8	NC	No internal connection, no need to connect;
9	Y	Drivers in-phase output
10	Z	Inverting output of the driver
11	B	Inverting input of the receiver
12	A	Receiver in-phase input terminal
13	VCC	This pin can be connected to the power supply ( $3\text{V} \leq \text{VCC} \leq 5.5\text{V}$ ) or can be left unconnected
14	VCC	Power supply: $3\text{V} \leq \text{VCC} \leq 5.5\text{V}$

## Extreme parameter

Parameter	Symbol	Unit	size
Continuous power consumption	SOP14	mW	600
	DIP14	mW	700
Power supply voltage	VCC	V	+7
working temperature range		°C	-40~125
Storage temperature range		°C	-60~150
Welding temperature range		°C	300
Control port voltage	DI	V	-0.3~VCC+0.3
Bus side input voltage	A, B	V	-8~13
Receiver output voltage	RO	V	-0.3~VCC+0.3

The maximum limit parameters are values beyond which the device can be damaged in an irreversible manner. Operation of the device under these conditions is not intended to be normal and may affect the reliability of the device if operated continuously at the maximum rated limit. All voltages are referenced to ground.



Parameter	Symbol	Test condition	Minimum	Typical case	Maximum	Unit
Supply current						
Supply current	Icc1	/RE=0V,DE=0V		220	400	uA
	Icc2	/RE=VCC,DE=		240	400	uA
Turn off the current	ISHDN	RE=VCC,DE=0V		0.5	10	uA
ESD protect						
A、B、Y、Z		Human body model(HBM)		±15		KV
Other ports		Human body model(HBM)		±6		KV
The DC electrical characteristics of the receiver						
Input current (A,B)	IN2	VCC=0 or 3.3 V VIN=12 V			125	uA
		VCC=0 or 3.3 V VIN=-7V	-100			uA
Forward input threshold voltage	VIT+	-7V≤VCM≤12 V			-10	mV
Reverse input threshold voltage	VIT-	-7V≤VCM≤12 V	-200			mV
Input the hysteresis voltage	Vhys	-7V≤VCM≤12 V	10	30		mV
High level output voltage	VoH	IoUT=-4mA,VID =+200 mV	VCC-1.5			V
Low-level output voltage	VoL	IoUT=+4mA,VID=-200 mV			0.4	V
Three-state input leakage current	IozR	0.4V<Vo<2.4V			±1	uA
Receiver input resistance	RN	-7V≤VCM≤12 V	96			kΩ
Receiver short-circuit current	IosR	0V≤Vo≤VCC	±7		±95	mA

(If not otherwise, VCC=3V~5.5V, Temp = TMIN ~ TMAX, typical value at Temp = 25 ) NOTE 1: VO D and? VOC is the change in VOD and VOC amplitude caused when the DI state of the input signal changes, respectively.



Parameter	Symbol	Test condition	Minimum	Typical case	Maximum	Unit
The DC electrical characteristics of the drive device						
Drive differential output(no load)	VoD?		3		5.5	V
Drive differential output	VoD2	Graph 2,RL=27Ω	1.5		VCC	V
		Graph 2,RL=50Ω	2		VCC	
Changes in the output voltage amplitude (NOTE1)	ΔVoD	Graph 2,RL=27Ω			0.2	V
Output common mode voltage	Voc	Graph 2,RL=27Ω			3	V
Change in common mode output voltage amplitude(NOTE 1)	ΔVoc	Graph 2,RL=27Ω			0.2	V
High-level input	VH	DI	2.0			V
Low level input	Vπ	DI			0.8	V
Logical input current	IN?	DI	-2		2	uA
Output short circuit current, short circuit to high	IosD?	Short-circuit to OV~12V	35		250	mA
Output short circuit current, short circuit to low	IosD2	Short-circuit to -7V~OV	-250		-35	mA
Drive switch characteristics						
Drive input to output propagation delay(low to high)	tDPLH	RDIFF=54Ω, CLi=CL?=100 pF (see Figure 3 and Figure 4)		15	35	ns
Drive input to output propagation delay(high to low)	tDPHL			15	35	ns
tDPLH-tDPHL	tsKEW1			7	10	ns
Up along time / down along time	tDR,tDF			10	25	ns
Amission to output high	tpZH	RL =1109,(see Figure 5,6)		20	90	ns
The enabling to output is low	tpZL			20	90	ns
Input low to no energy	tPLz	RL =110 Ω, (see Figure		20	80	ns
Input high to no energy	tPHZ			20	80	ns
Under off conditions,the output is high	tDSH	RL =1109,(see Figure 5,6)		500	900	ns
Under off conditions,enabling output low	tDSL	RL=1109,(see Figure 5,6)		500	900	ns



Parameter	Symbol	Test condition	Minimum	Typical case	Maximum	Unit
Receiver Switch characteristics						
Ento output high time	tRPZH	C=15 pF is shown in Figure		20	50	ns
From low output to energy-forbidden time	tpRLZ	For CL =15 pF, see Figure 7		20	45	ns
From high output to energy forbidden time	tPRHZ	For CL =15 pF, see Figure 7		20	45	ns
Enables high output time in the off state	tRPSH	For CL =15 pF, see Figure 7		200	1400	ns
Ento output low time in off state	tRPSL	For CL =15 pF, see Figure 7		200	1400	ns
Time in the off state	tsHDN	NOTE2	80		300	ns
Acceptor	tRPLH	See Figure 7 and Figure 8	20	60	90	ns
Input to output propagation latency is from low to high						
The receiver input to output propagation latency is obtained from high to low	tRPHL	VID 2.0V;rise and fall along time VID 15ns	20	60	90	ns
tRPLH-tRPHL	tsKEW2			7	10	ns
Ability to reach the output for a low time	tRPZL	For CL =15 pF, see Figure 7		20	50	ns

## Test circuit

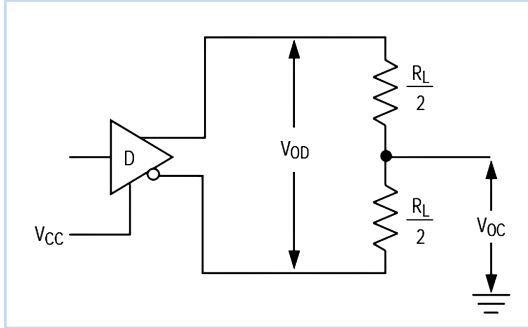

Figure 2: DC test load for the drive

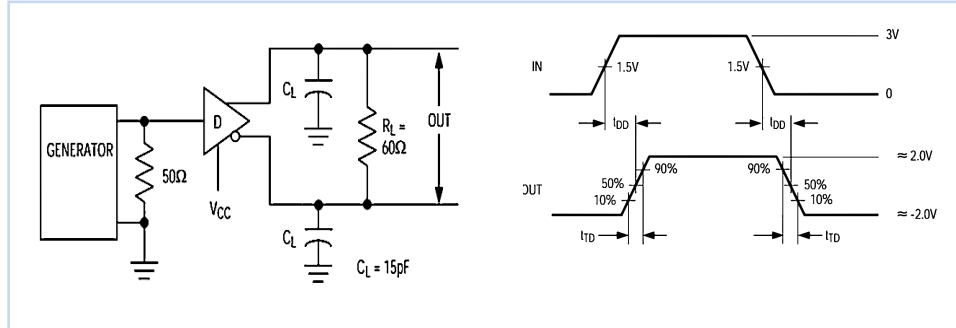

Figure 3 Drive-line Differential Delay and Transit Time

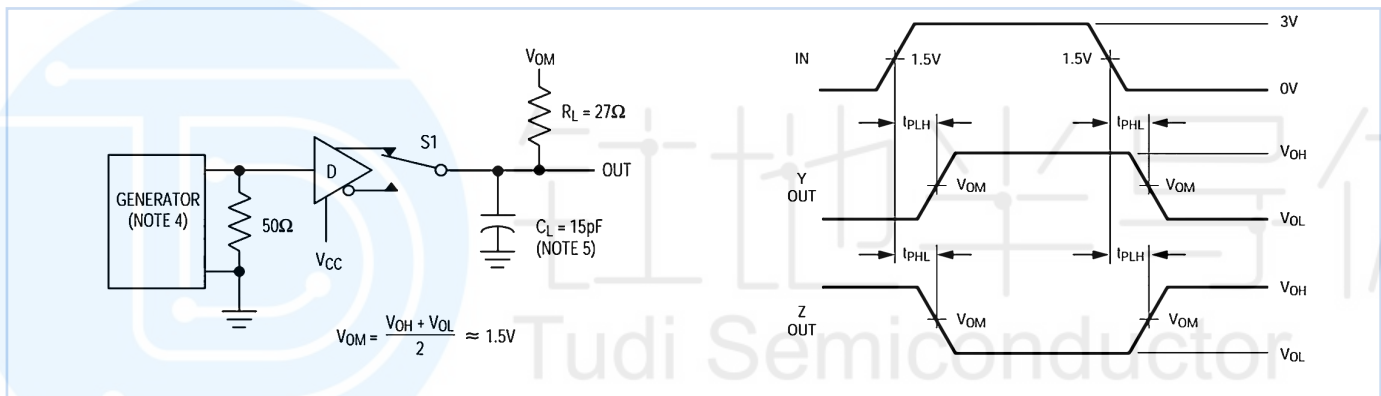

Figure 4 Drive propagation delay

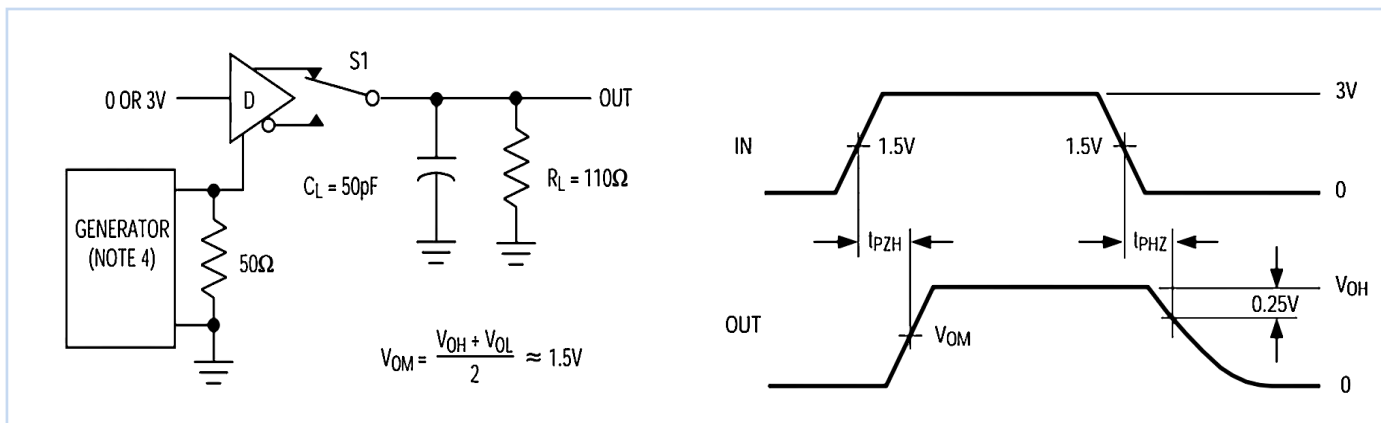

Figure 5 Drive enable and disable time

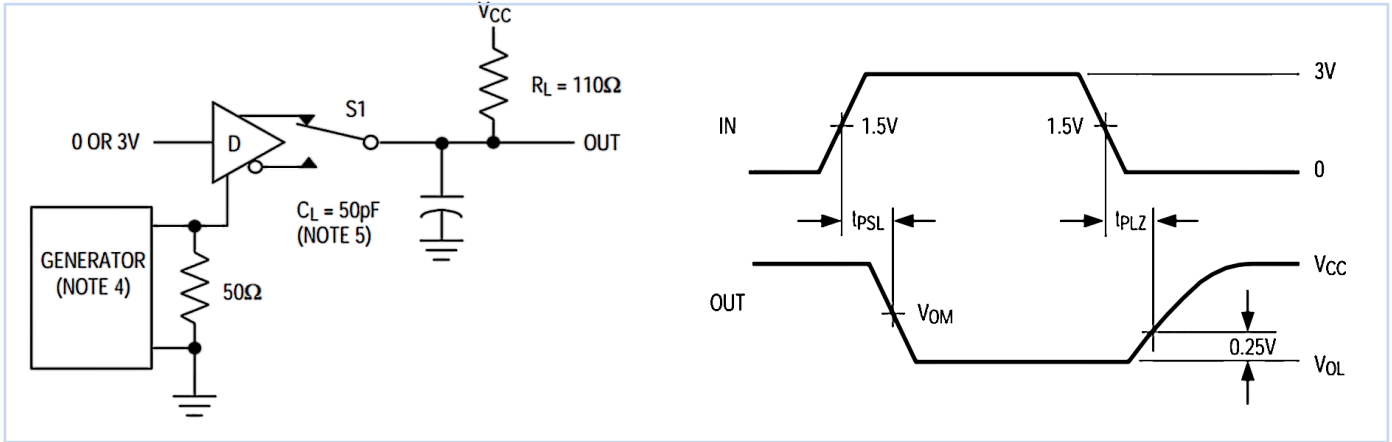

Figure 6 Drive enable and disable time

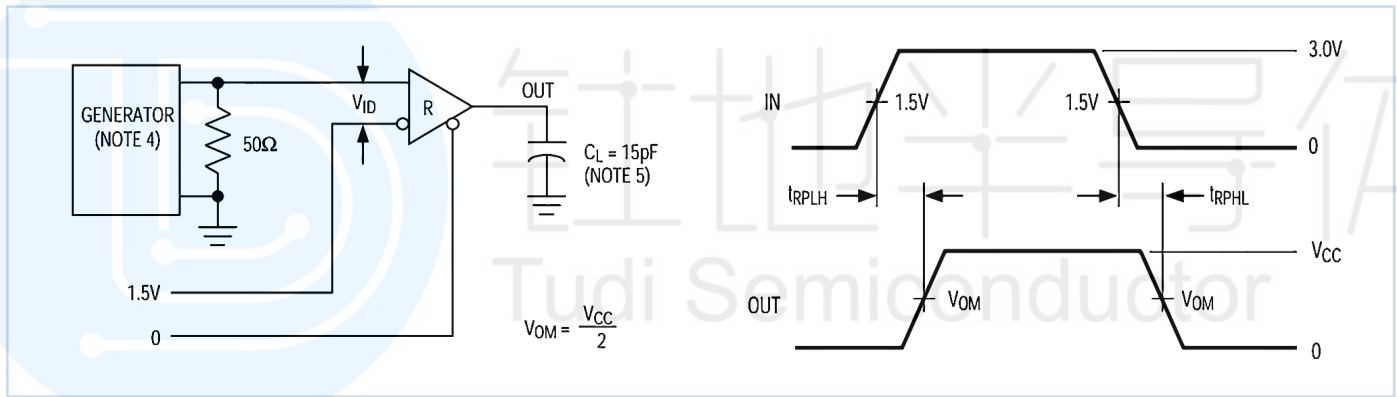
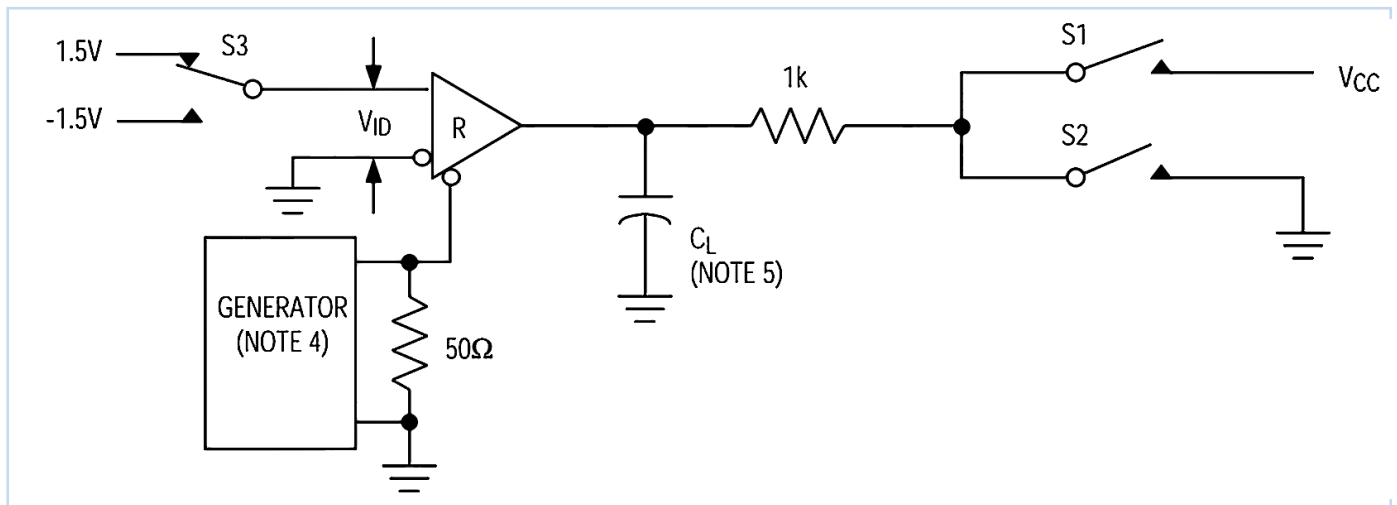

Figure 7: Receiver Propagation Delay Test Circuit



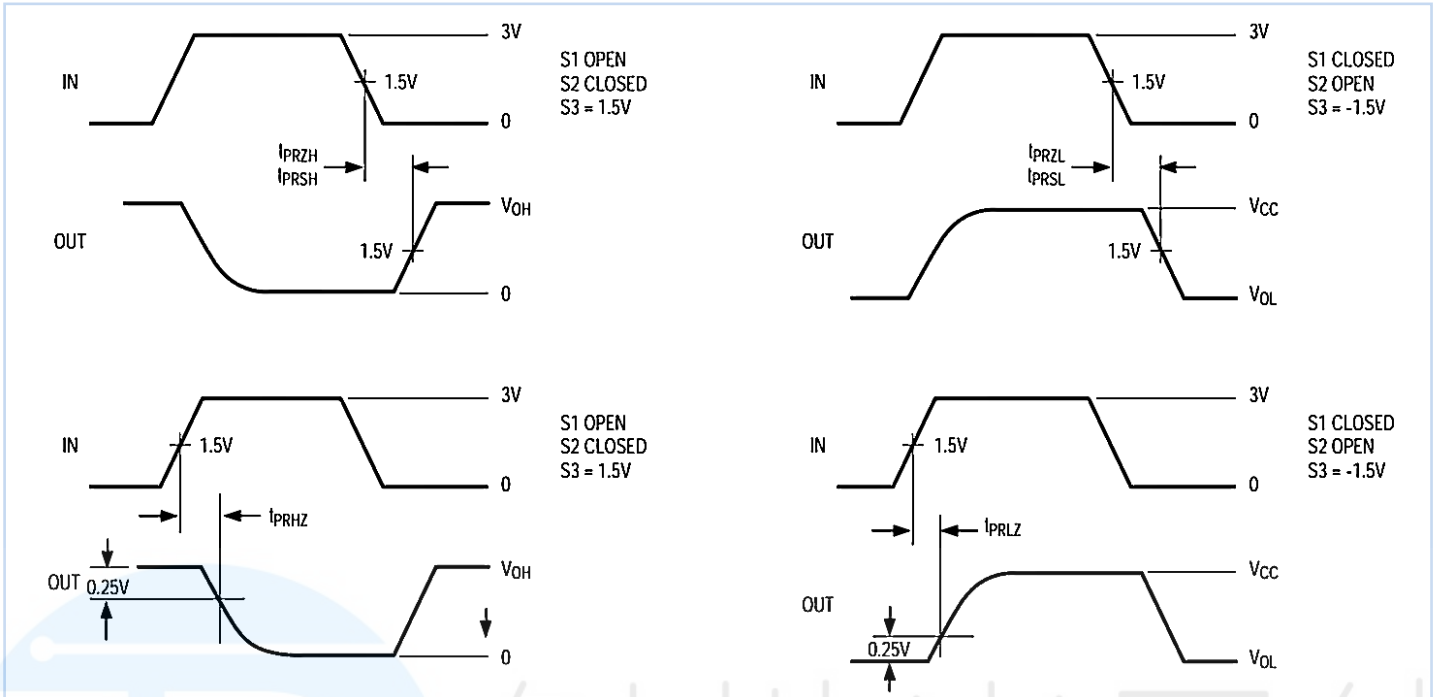

Figure 8 Receive enable and disable time

## Order information

Order Number	Package	Package Quantity	Marking On The park	Temperature
SN65HVD55DR-TUDI	SOP14	Tape,Reel,2500	HVD55	- 40°C to 85°C
SN65HVD55N-TUDI	DIP14	Tube,25,A box of 1000	SN65HVD55N	
SN65HVD54DR-TUDI	SOP14	Tape,Reel,2500	HVD54	
SN65HVD54N-TUDI	DIP14	Tube,25,A box of 1000	SN65HVD54N	
SN65HVD53DR-TUDI	SOP14	Tape,Reel,2500	HVD53	
SN65HVD53N-TUDI	DIP14	Tube,25,A box of 1000	SN65HVD53N	



# Package SOP14

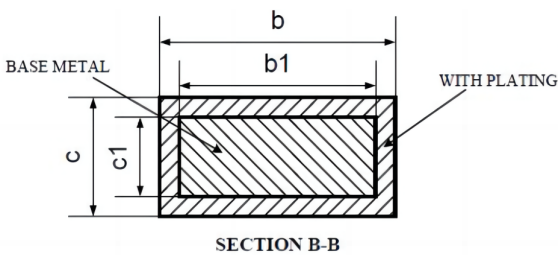
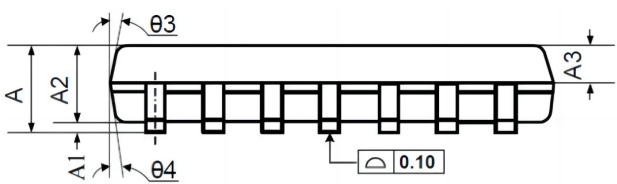
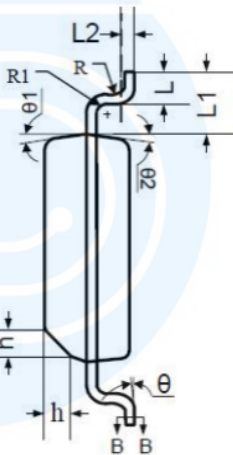
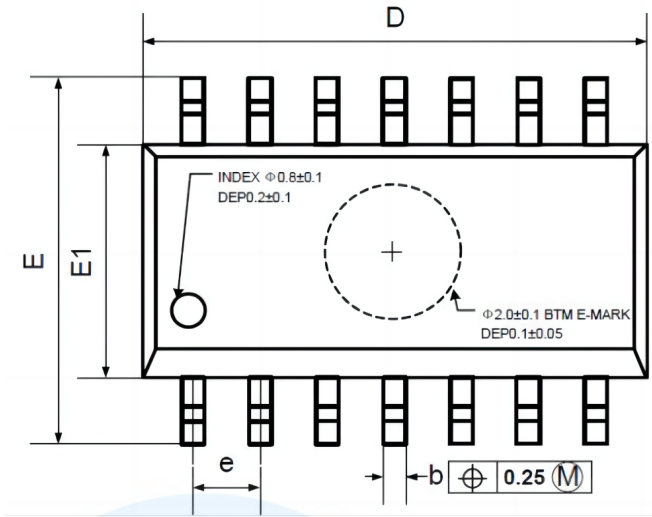

Symbol	Dimensions In Millimeters		
	MIN	NOM	MAX
A	1.35	1.60	1.75
A1	0.10	0.15	0.25
A2	1.25	1.45	1.65
A3	0.55	0.65	0.75
b	0.36		0.49
b1	0.35	0.40	0.45
C	0.16		0.25
c1	0.15	0.20	0.25
D	8.53	8.63	8.73
E	5.80	6.00	6.20
E1	3.80	3.90	4.00
e	1.27 BSC		
L	0.45	0.60	0.80
L1	1.04 REF		
L2	0.25 BSC		
R	0.07		
R1	0.07		
h	0.30	0.40	0.50
θ	0°		8°
θ1	6°	8°	10°
θ2	6°	8°	10°
θ3	5°	7°	9°
θ4	5°	7°	9°



## Package DIP14

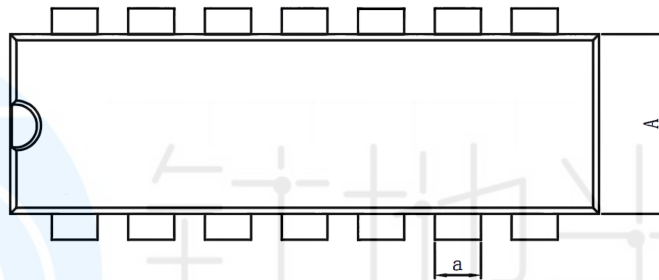
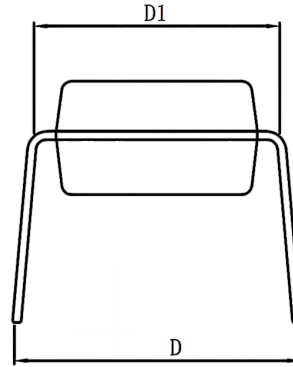
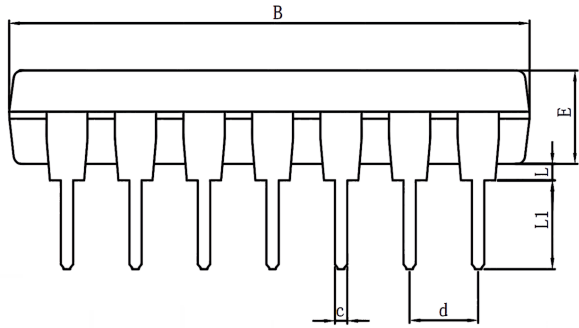

DIM.	MIN	TYP	MAX	DIM.	MIN	TYP	MAX
A	6.100	6.300	6.680	a	1.504	1.524	1.544
B	18.940	19.200	19.560	C	0.437	0.457	0.477
D	8.200	8.700	9.200	d	2.530	2.540	2.550
D1	7.42	7.62	7.82	L	0.500	—	0.800
E	3.100	3.300	3.550	L1	3.000	3.200	3.600



## Important statement:

- TUDI Semiconductor reserves the right to modify the product manual without prior notice! Before placing an order, customers need to confirm whether the obtained information is the latest version and verify the completeness of the relevant information.
- Any semi-guide product is subject to failure or malfunction under specified conditions. It is the buyer's responsibility to comply with safety standards when using TUDI Semiconductor products for system design and whole machine manufacturing. And take the appropriate safety measures to avoid the potential in the risk of loss of personal injury or loss of property situation!
- TUDI Semiconductor products have not been licensed for life support, military, and aerospace applications, and therefore TUDI Semiconductor is not responsible for any consequences arising from the use of this product in these areas.
- If any or all TUDI Semiconductor products (including technical data, services) described or contained in this document are subject to any applicable local export control laws and regulations, they may not be exported without an export license from the relevant authorities in accordance with such laws.
- The specifications of any and all TUDI Semiconductor products described or contained in this document specify the performance, characteristics, and functionality of said products in their standalone state, but do not guarantee the performance, characteristics, and functionality of said products installed in Customer's products or equipment. In order to verify symptoms and conditions that cannot be evaluated in a standalone device, the Customer should ultimately evaluate and test the device installed in the Customer's product device.
- TUDI Semiconductor documentation is only allowed to be copied without any alteration of the content and with the relevant authorization. TUDI Semiconductor assumes no responsibility or liability for altered documents.
- TUDI Semiconductor is committed to becoming the preferred semiconductor brand for customers, and TUDI Semiconductor will strive to provide customers with better performance and better quality products.