



钰地半导体
Tudi Semiconductor

Tudi Semiconductor

Product Specification

TUDI-SN65HVD73

3.3V full-duplex RS-485 transceiver with $\pm 12\text{kV}$ IEC ESD

网址 www.sztdbdt.com 🔍

用芯智造 · 卓越品质

**semiconductor device
manufacturer**

- Design
- research and development
- production
- and sales



Features

- 1/8 unit load option available
 - Up to 256 nodes on one bus
- Bus I/O protection
 - > ±30kV Human Body Model (HBM) protection
 - > ±12kV IEC61000-4-2 discharge
 - > ±4kV IEC61000-4-4 Fast transient pulse
- Industrial operating temperature range: -40°C 125°C
- Large receiver hysteresis (70mV) for noise suppression
- Low power consumption
 - < 1.1 static current during operation
 - Low standby power current: 10nA (typical), < 5µA (max)
- No-ference power up and power down protection for hot-plug applications
- 5V tolerant logic inputs compatible with 3.3V or 5V

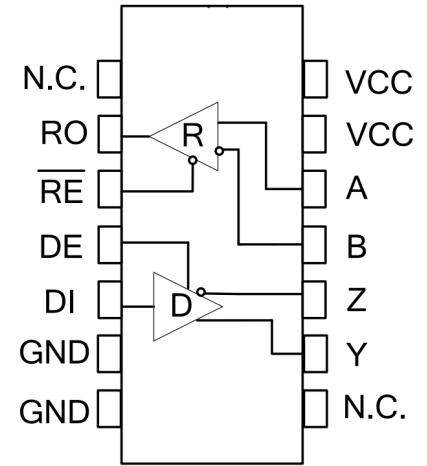

Figure 1 Pin diagram

Description

The devices extend the RS-485 product offering to include a family of full-duplex transceivers with robust 3.3V drivers and receivers and advanced ESD protection. The devices feature larger receiver hysteresis to suppress conducted differential noise and a wide operating temperature range to maintain reliability in harsh operating environments. The device contains a differential driver and a differential receiver, both of which are powered and operated by a 3.3V single supply. Each driver and receiver has independent input and output for full-duplex bus communication designs. The devices feature a wide common mode voltage range, making them ideal for multi-point applications on long cables. The HVD73 features a high-level-active driver enable and a low-level-active receiver enable. The rated operating temperature range is -40°C to 125°C.

Applications

- Electronic meter
- Industrial automation
- Building automation
- Security and surveillance
- Encoder and decoder



Pin description

Pin number	Pin name	Pin function
1	NC	No internal connection, no need to connect;
2	RO	Receiver output. When /RE is low, if $A-B \geq -10\text{mV}$, RO output is high; if $AB \leq -200\text{mV}$, RO output is low.
3	/RE	Receiver output enable control. When /RE is low, the receiver output is enabled and RO is valid; when /RE is high, the receiver is disabled and RO is high impedance; /RE is high and DE is low, the device enters low-power off mode.
4	DE	Driver output enable control. The driver output is active when DE is high, and the output is high-impedance when DE is low; / is high and DE is low, the device enters low-power shutdown mode.
5	DI	DI driver input. A low on DI with DE high causes the driver's A output to be low and B output to be high; a high DI will cause the A output to be high and the B output to be low.
6	GND	grounding
7	GND	grounding
8	NC	No internal connection, no need to connect;
9	Y	Drivers in-phase output
10	Z	Inverting output of the driver
11	B	Inverting input of the receiver
12	A	Receiver in-phase input terminal
13	VCC	This pin can be connected to the power supply ($3\text{V} \leq \text{VCC} \leq 5.5\text{V}$) or can be left unconnected
14	VCC	Power supply: $3\text{V} \leq \text{VCC} \leq 5.5\text{V}$

Extreme parameter

Parameter	Symbol	Unit	size
Continuous power consumption	SOP14	mW	600
	DIP14	mW	700
Power supply voltage	VCC	V	+7
working temperature range		°C	-40~125
Storage temperature range		°C	-60~150
Welding temperature range		°C	300
Control port voltage	DI	V	-0.3~VCC+0.3
Bus side input voltage	A, B	V	-8~13
Receiver output voltage	RO	V	-0.3~VCC+0.3

The maximum limit parameters are values beyond which the device can be damaged in an irreversible manner. Operation of the device under these conditions is not intended to be normal and may affect the reliability of the device if operated continuously at the maximum rated limit. All voltages are referenced to ground.



Parameter	Symbol	Test condition	Minimum	Typical case	Maximum	Unit
Supply current						
Supply current	Icc1	/RE=0V,DE=0V		220	400	uA
	Icc2	/RE=VCC,DE=		240	400	uA
Turn off the current	ISHDN	RE=VCC,DE=0V		0.5	10	uA
ESD protect						
A、B、Y、Z		Human body model(HBM)		±15		KV
Other ports		Human body model(HBM)		±6		KV
The DC electrical characteristics of the receiver						
Input current (A,B)	IN2	VCC=0 or 3.3 V VIN=12 V			125	uA
		VCC=0 or 3.3 V VIN =-7V	-100			uA
Forward input threshold voltage	VIT+	-7V≤VCM≤12 V			-10	mV
Reverse input threshold voltage	VIT-	-7V≤VCM≤12 V	-200			mV
Input the hysteresis voltage	Vhys	-7V≤VCM≤12 V	10	30		mV
High level output voltage	VoH	IoUT=-4mA,VID =+200 mV	VCC-1.5			V
Low-level output voltage	VoL	IoUT=+4mA,VID=-200 mV			0.4	V
Three-state input leakage current	IozR	0.4V<Vo<2.4V			±1	uA
Receiver input resistance	RN	-7V≤VCM≤12 V	96			kΩ
Receiver short-circuit current	IosR	0V≤Vo≤VCC	±7		±95	mA

(If not otherwise, VCC=3V~5.5V, Temp = TMIN ~ TMAX, typical value at Temp = 25) NOTE 1: VO D and? VOC is the change in VOD and VOC amplitude caused when the DI state of the input signal changes, respectively.



Parameter	Symbol	Test condition	Minimum	Typical case	Maximum	Unit
The DC electrical characteristics of the drive device						
Drive differential output(no load)	VoD?		3		5.5	V
Drive differential output	VoD2	Graph 2,RL=27Ω	1.5		VCC	V
		Graph 2,RL=50Ω	2		VCC	
Changes in the output voltage amplitude (NOTE1)	ΔVoD	Graph 2,RL=27Ω			0.2	V
Output common mode voltage	Voc	Graph 2,RL=27Ω			3	V
Change in common mode output voltage amplitude(NOTE 1)	ΔVoc	Graph 2,RL=27Ω			0.2	V
High-level input	VH	DI	2.0			V
Low level input	Vπ	DI			0.8	V
Logical input current	IN?	DI	-2		2	uA
Output short circuit current, short circuit to high	IosD?	Short-circuit to OV~12V	35		250	mA
Output short circuit current, short circuit to low	IosD2	Short-circuit to -7V~OV	-250		-35	mA
Drive switch characteristics						
Drive input to output propagation delay(low to high)	tDPLH	RDIFF=54Ω, CLi=CL?=100 pF (see Figure 3 and Figure 4)		15	35	ns
Drive input to output propagation delay(high to low)	tDPHL			15	35	ns
tDPLH-tDPHL	tsKEW1			7	10	ns
Up along time / down along time	tDR,tDF			10	25	ns
Amission to output high	tpZH	RL =1109,(see Figure 5,6)		20	90	ns
The enabling to output is low	tpZL			20	90	ns
Input low to no energy	tPLz	RL =110 Ω, (see Figure		20	80	ns
Input high to no energy	tPHZ			20	80	ns
Under off conditions,the output is high	tDSH	RL =1109,(see Figure 5,6)		500	900	ns
Under off conditions,enabling output low	tDSL	RL=1109,(see Figure 5,6)		500	900	ns



Parameter	Symbol	Test condition	Minimum	Typical case	Maximum	Unit
Receiver Switch characteristics						
Ento output high time	tRPZH	C=15 pF is shown in Figure		20	50	ns
From low output to energy-forbidden time	tpRLZ	For CL =15 pF, see Figure 7		20	45	ns
From high output to energy forbidden time	tPRHZ	For CL =15 pF, see Figure 7		20	45	ns
Enables high output time in the off state	tRPSH	For CL =15 pF, see Figure 7		200	1400	ns
Ento output low time in off state	tRPSL	For CL =15 pF, see Figure 7		200	1400	ns
Time in the off state	tsHDN	NOTE2	80		300	ns
Acceptor	tRPLH	See Figure 7 and Figure 8	20	60	90	ns
Input to output propagation latency is from low to high						
The receiver input to output propagation latency is obtained from high to low	tRPHL	VID 2.0V;rise and fall along time VID 15ns	20	60	90	ns
tRPLH-tRPHL	tsKEW2			7	10	ns
Ability to reach the output for a low time	tRPZL	For CL =15 pF, see Figure 7		20	50	ns

Additional description

Introduction

The HVD73 is a full-duplex high-speed transceiver for RS-485/RS-42 communication, containing a driver and a receiver. It has fail-safe, overvoltage protection, and overcurrent protection. The HVD73 achieves error-free transmission up to 12Mbps.

fail-safe

The HVD73 guarantees a logic high receiver output if the receiver input is short-circuited or open-circuited, or drivers connected to the terminated transmission line are disabled (idle). This is achieved by setting the receiver input thresholds to -10mV and -20mV, respectively. RO is logic high if the differential receiver input voltage(A-B) ≥ -10mV, and RO is logic low the voltage(A-B) ≤ -200mV. Logic high with a minimum noise margin of 50mV can be realized depending the receiver thresholds. The -10mV to -200mV threshold voltage is in accordance with the EIA/TIA-485 of ±200mV.

256 transceivers on the bus

The input impedance of the standard RS485 receiver is 12k (1 unit load), and the standard driver can drive to 32 unit loads. The receiver of the HVD73 transceiver has an input impedance of 1/8 unit load (96k), allowing up to 256 transceivers to be connected in parallel on the same communication bus. These devices can be combined arbitrarily, or combined with other 485 transceivers, as long as the total load does not exceed 256 unit loads, they can be connected to the same bus.

Drive output protection

Protection against excessive output current and dissipation by fault or bus contention is provided by overcurrent and overvoltage protection mechanisms, with fast short-circuit throughout the common-mode voltage range (see Typical Operating Characteristics).

Test circuit

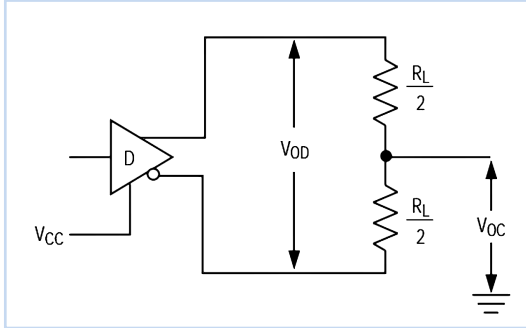

Figure 2: DC test load for the drive

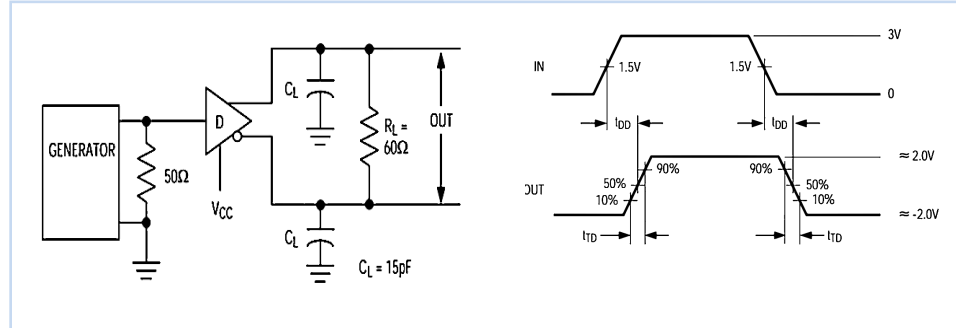

Figure 3 Drive-line Differential Delay and Transit Time

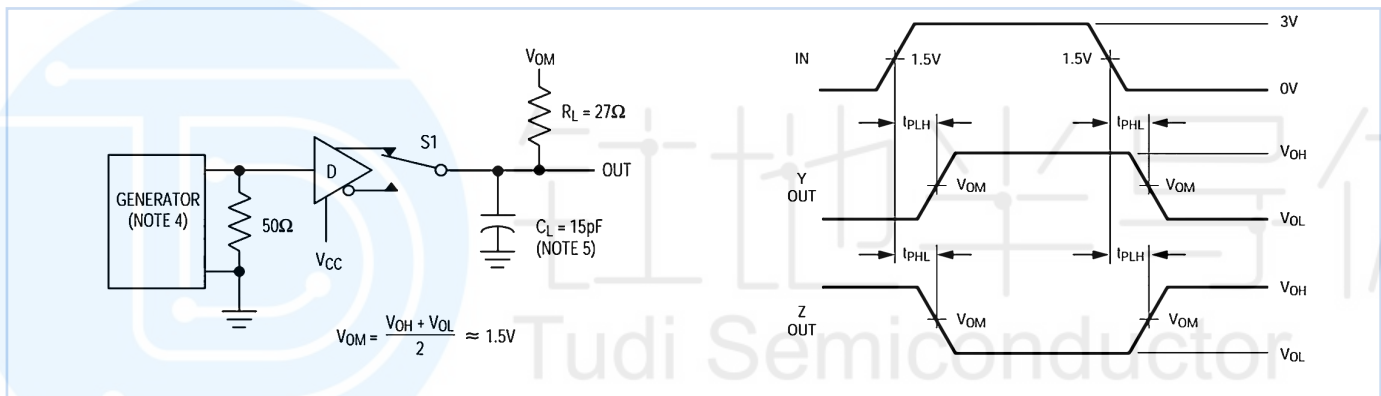

Figure 4 Drive propagation delay

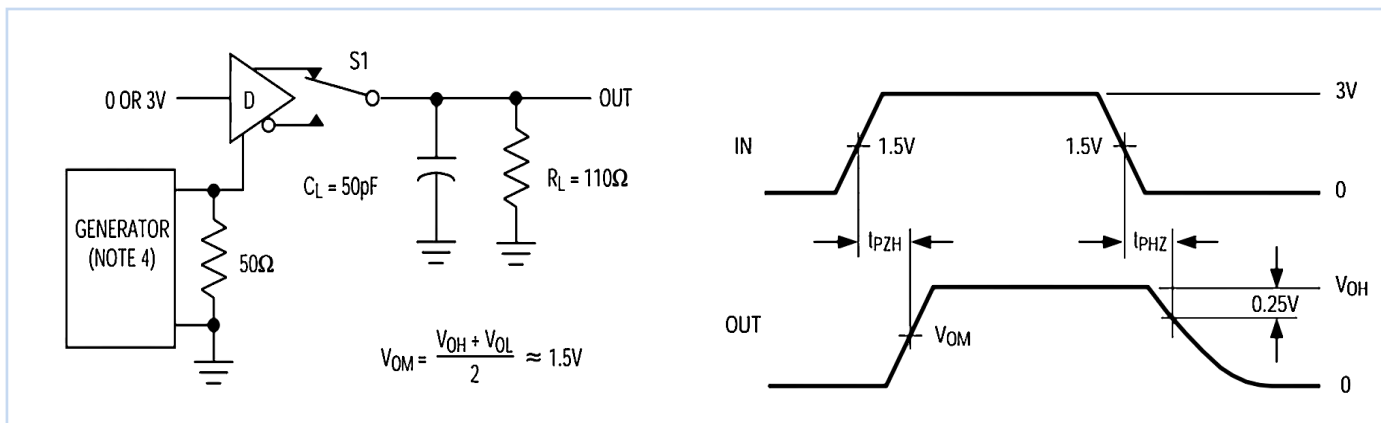

Figure 5 Drive enable and disable time

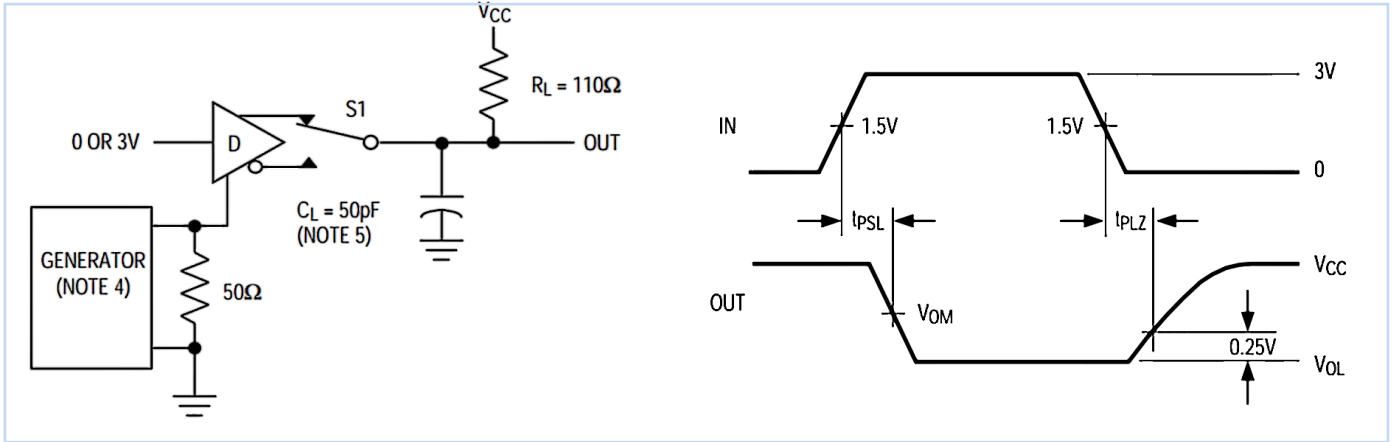

Figure 6 Drive enable and disable time

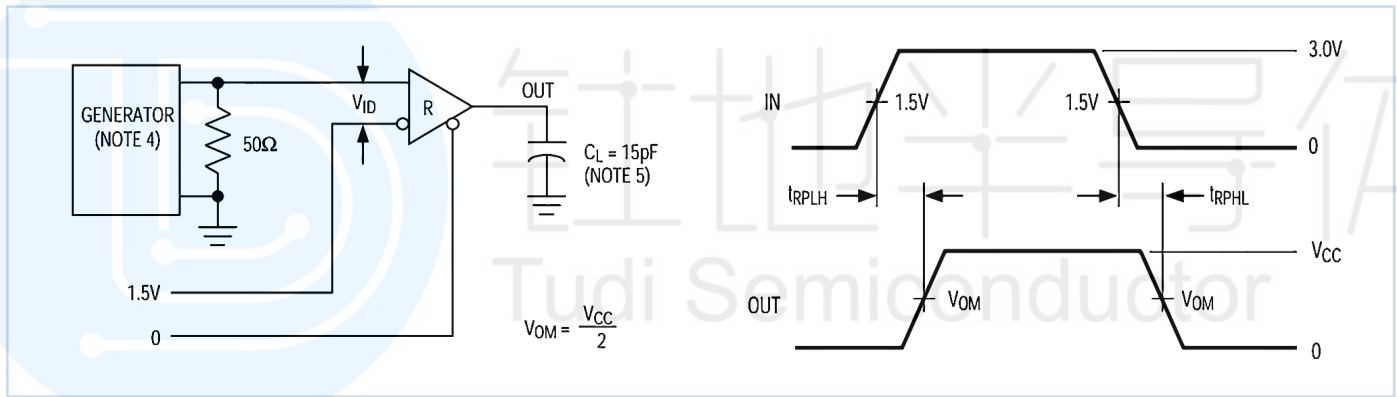
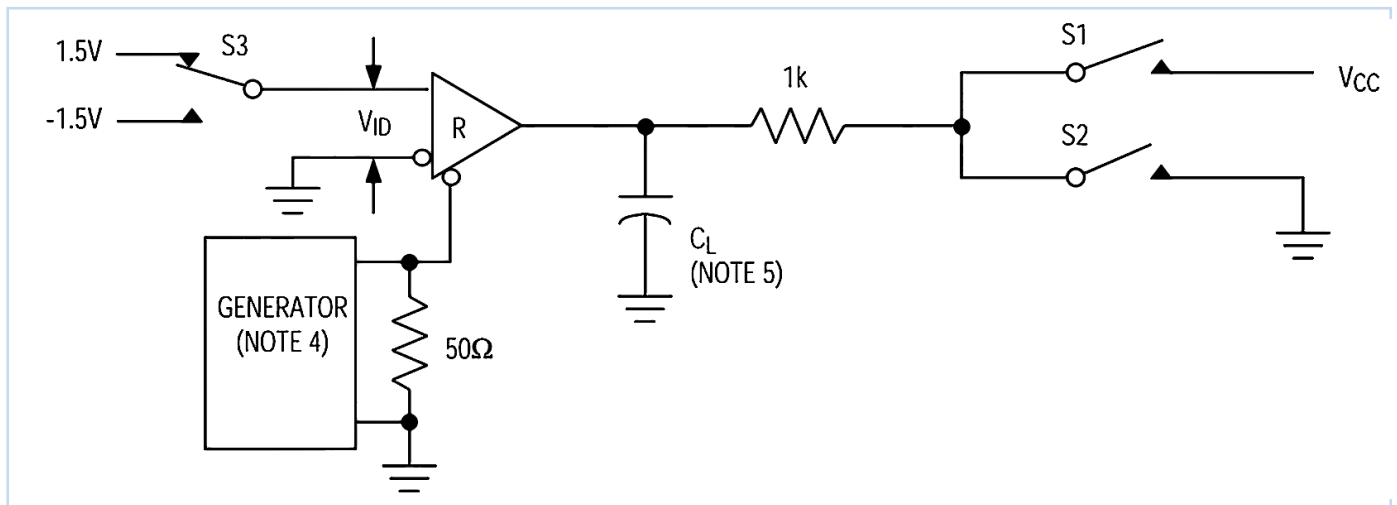

Figure 7: Receiver Propagation Delay Test Circuit



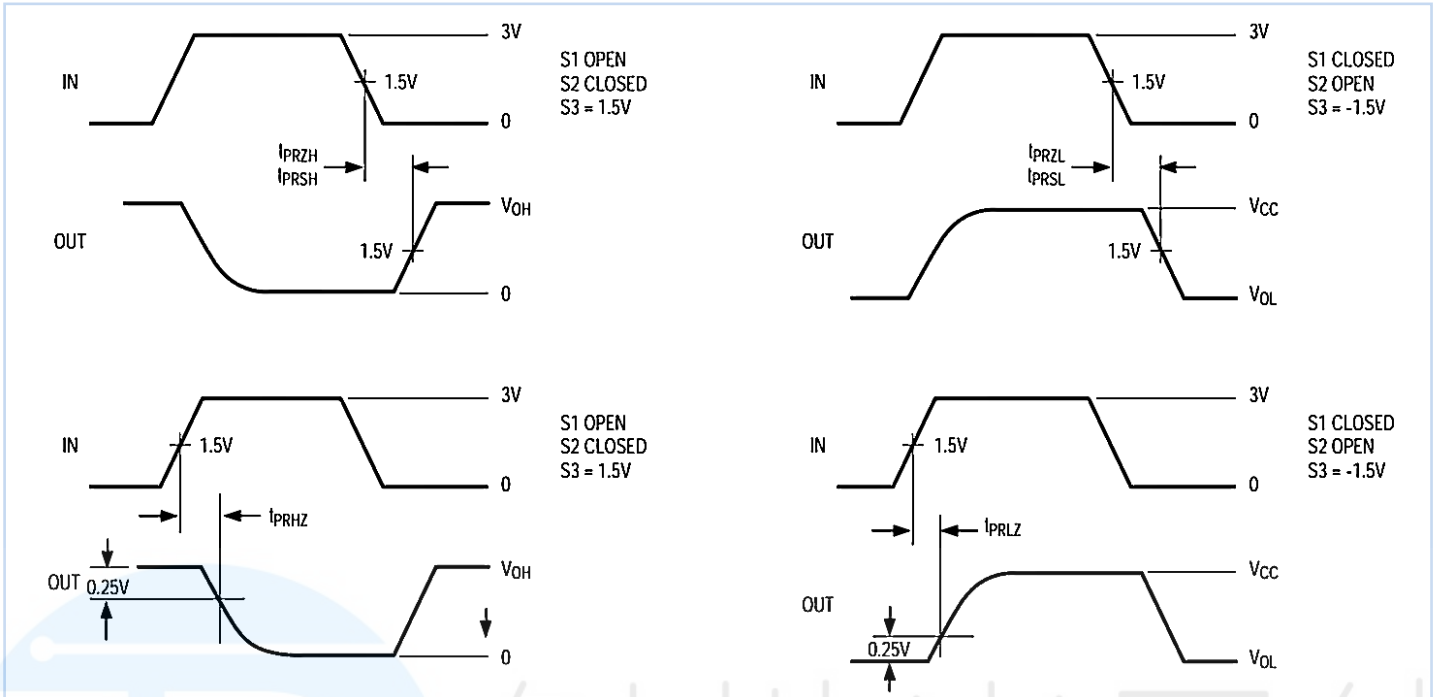

Figure 8 Receive enable and disable time

Order information

Order Number	Package	Package Quantity	Marking On The park	Temperature
SN65HVD73DR-TUDI	SOP14	Tape,Reel,2500	HVD73	- 40°C to 125°C
SN65HVD73N-TUDI	DIP14	Tube,25,A box of 2000	SN65HVD73N	



Package SOP14

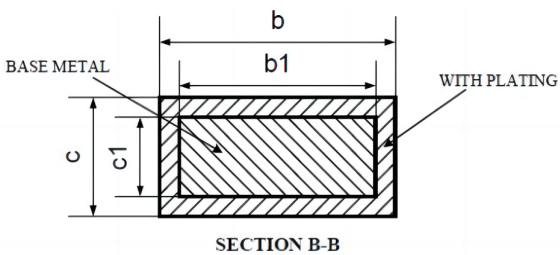
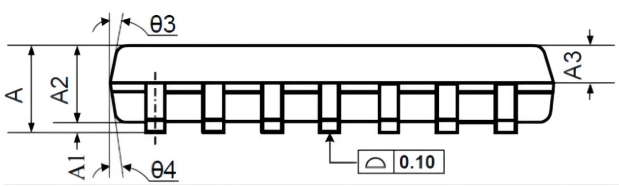
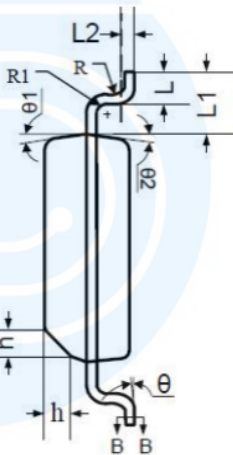
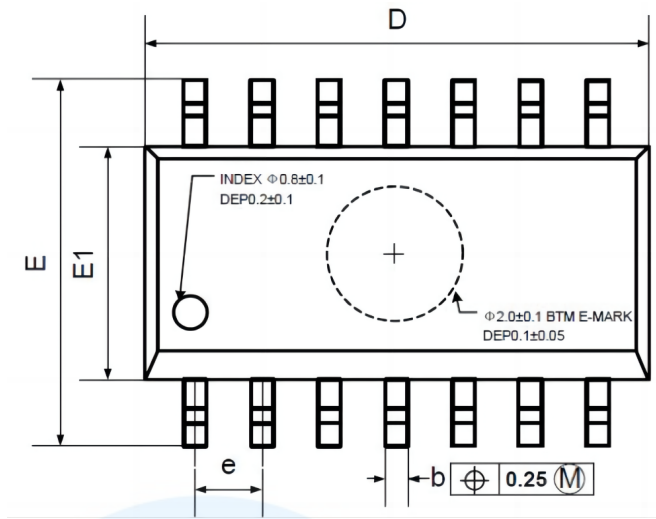

Symbol	Dimensions In Millimeters		
	MIN	NOM	MAX
A	1.35	1.60	1.75
A1	0.10	0.15	0.25
A2	1.25	1.45	1.65
A3	0.55	0.65	0.75
b	0.36		0.49
b1	0.35	0.40	0.45
C	0.16		0.25
c1	0.15	0.20	0.25
D	8.53	8.63	8.73
E	5.80	6.00	6.20
E1	3.80	3.90	4.00
e	1.27 BSC		
L	0.45	0.60	0.80
L1	1.04 REF		
L2	0.25 BSC		
R	0.07		
R1	0.07		
h	0.30	0.40	0.50
θ	0°		8°
θ1	6°	8°	10°
θ2	6°	8°	10°
θ3	5°	7°	9°
θ4	5°	7°	9°



Package TSSOP14

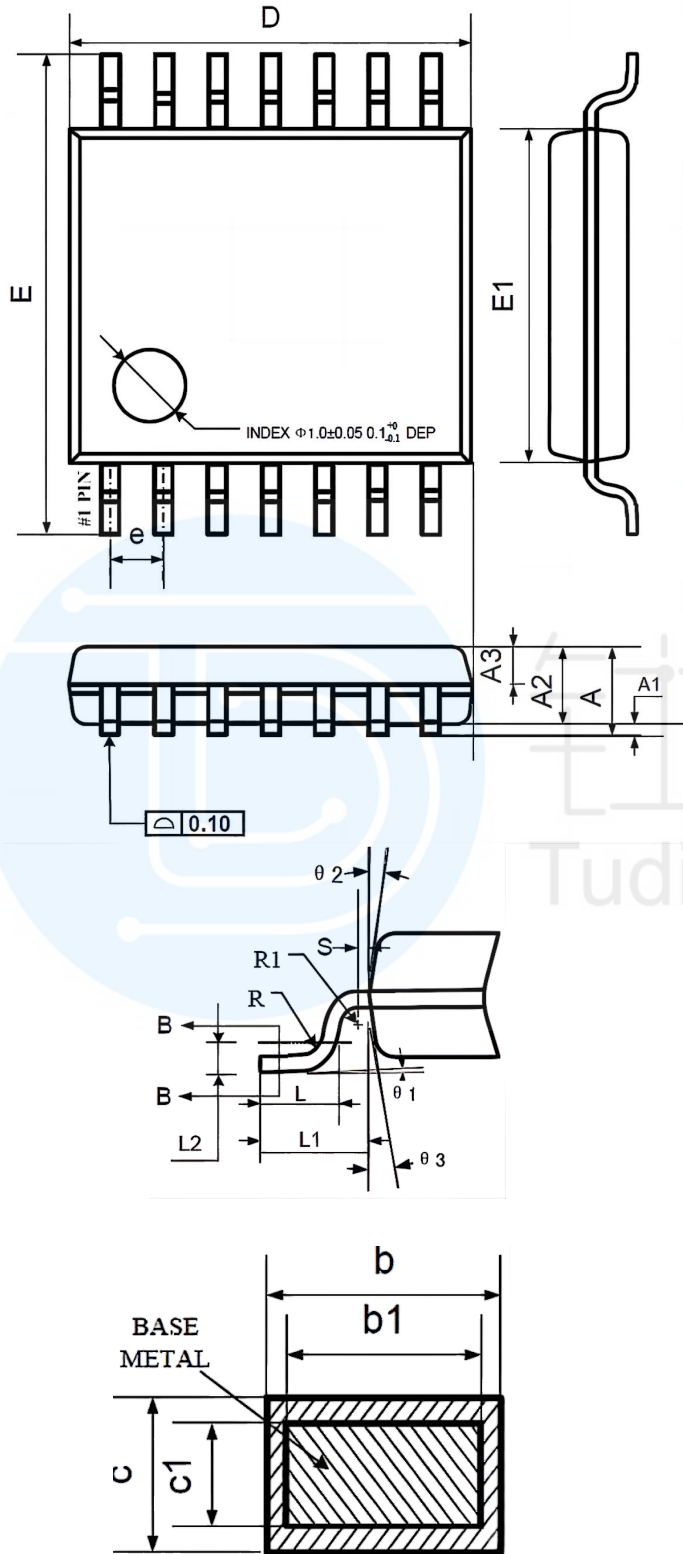

Symbol	Dimensions In Millimeters		
	MIN	NOM	MAX
A	—	—	1.20
A1	0.05	—	0.15
A2	0.90	1.00	1.05
A3	0.34	0.44	0.54
b	0.20	—	0.28
b1	0.20	0.22	0.24
C	0.10	—	0.19
c1	0.10	0.13	0.15
D	4.86	4.96	5.06
E	6.20	6.40	6.60
E1	4.30	4.40	4.50
e	0.65 BSC		
L	0.45	0.60	0.75
L1	1.00 REF		
L2	0.25 BSC		
R	0.09	—	—
R1	0.09	—	—
S	0.20	—	—
$\theta 1$	0°	—	8°
$\theta 2$	10°	12°	14°
$\theta 3$	10°	12°	14°



Package DIP14

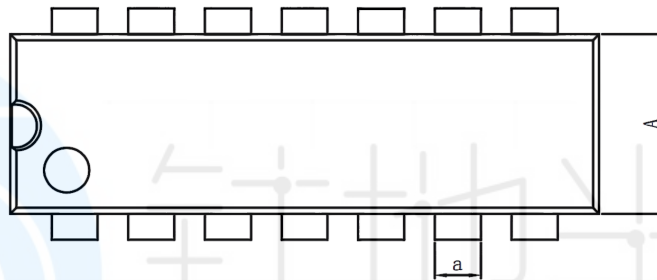
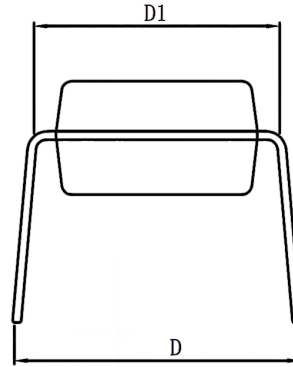
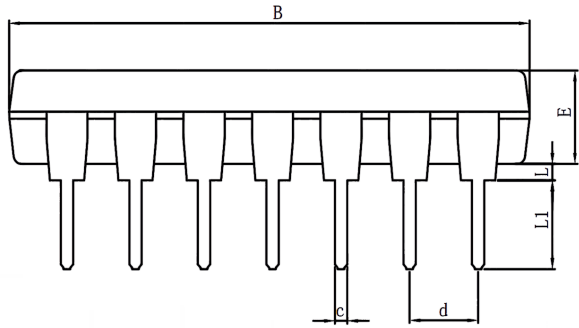

DIM.	MIN	TYP	MAX	DIM.	MIN	TYP	MAX
A	6.100	6.300	6.680	a	1.504	1.524	1.544
B	18.940	19.200	19.560	C	0.437	0.457	0.477
D	8.200	8.700	9.200	d	2.530	2.540	2.550
D1	7.42	7.62	7.82	L	0.500	—	0.800
E	3.100	3.300	3.550	L1	3.000	3.200	3.600



Important statement:

- TUDI Semiconductor reserves the right to modify the product manual without prior notice! Before placing an order, customers need to confirm whether the obtained information is the latest version and verify the completeness of the relevant information.
- Any semi-guide product is subject to failure or malfunction under specified conditions. It is the buyer's responsibility to comply with safety standards when using TUDI Semiconductor products for system design and whole machine manufacturing. And take the appropriate safety measures to avoid the potential in the risk of loss of personal injury or loss of property situation!
- TUDI Semiconductor products have not been licensed for life support, military, and aerospace applications, and therefore TUDI Semiconductor is not responsible for any consequences arising from the use of this product in these areas.
- If any or all TUDI Semiconductor products (including technical data, services) described or contained in this document are subject to any applicable local export control laws and regulations, they may not be exported without an export license from the relevant authorities in accordance with such laws.
- The specifications of any and all TUDI Semiconductor products described or contained in this document specify the performance, characteristics, and functionality of said products in their standalone state, but do not guarantee the performance, characteristics, and functionality of said products installed in Customer's products or equipment. In order to verify symptoms and conditions that cannot be evaluated in a standalone device, the Customer should ultimately evaluate and test the device installed in the Customer's product device.
- TUDI Semiconductor documentation is only allowed to be copied without any alteration of the content and with the relevant authorization. TUDI Semiconductor assumes no responsibility or liability for altered documents.
- TUDI Semiconductor is committed to becoming the preferred semiconductor brand for customers, and TUDI Semiconductor will strive to provide customers with better performance and better quality products.