



钰地半导体  
Tudi Semiconductor

## Product Specification

TUDI-SN65HVD72

3.3V power supply with IEC ESD protection RS-485

网址 [www.sztdbdt.com](http://www.sztdbdt.com) 🔍

**用芯智造 · 卓越品质**

**semiconductor device  
manufacturer**

- Design
- research and development
- production
- and sales



## Features

- Bus I/O protection
  - $> \pm 15\text{kV}$  Human Body Model (HBM) protection
  - $> \pm 12\text{kV}$  I 61000-4-2 Contact discharge
  - $> \pm 4\text{kV}$  IEC 61000-4-4 Fast transient burst
- industrial temperature range  $-40^\circ\text{C}$  to  $125^\circ\text{C}$
- Larger receiver hysteresis for noise suppression
- Low unit load allows connection of more 200 nodes
- Low power consumption
- 5V tolerant logic inputs compatible with 3.3V or 5V controllers
- Signal transmission rate 250kbps
- Undisturbed power up and power down bus inputs and outputs

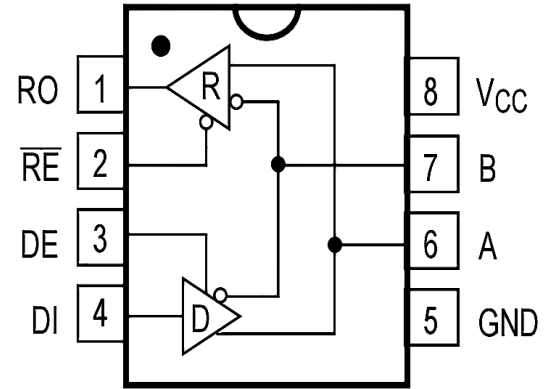

Figure 1. Pin Diagram

## Description

These devices feature robust 3.3V drivers and receivers in a small package, making them ideal for industrial applications. The bus pins can withstand E events with a high level of protection for both the human body model and the IEC contact discharge specification. Each device incorporates a differential driver and a differential receiver. These two devices powered by a single 3.3V supply. The driver differential output and the receiver differential input are internally connected to form a bus port suitable for half-duplex (twowire bus) communication. These devices have a wide common mode voltage range, making them ideal for long cable runs. These devices are rated to operate over the temperature range of  $-40^\circ\text{C}$  to  $125^\circ\text{C}$ .

## Applications

- Factory automation
- Telecommunications infrastructure
- Motion control



## Pin description

Pin Number	Pin Name	FUNCTION
1	RO	Receiver Output. When enabled, if $A-B \geq -10\text{mV}$ , then $RO = \text{high}$ . If $A-B \leq -200\text{mV}$ , then $RO = \text{low}$
2	/RE	Receiver Output Enable. A low level enables the RO; a high level places it in a high impedance state.
3	DE	Driver Output Enable. A high level enables the driver differential outputs, Pin A and Pin B; a low level places the driver in a high impedance state.
4	DI	Driver Input. When the driver is enabled, a logic low on DI forces Pin A low and Pin B high; a logic high on DI forces Pin A high and Pin B low.
5	GND	Ground Connection (0V).
6	A	No inverting Receiver Input A/Driver Output A
7	B	Inverting Receiver Input B/Driver Output B.
8	VCC	Power Supply

## Parameter limit

PARAMETER	Symbol	Value	Unit
CTR Port	/RE, DE, DI	-0.3~VCC+0.3	V
Driver Output Voltage	A, B	-7~13	V
Receiver Output Voltage	RO	-0.3~VCC+0.3	V
Supply Voltage	VCC	+7	V
Continuous Power Dissipation	MSOP8.SOP8.DIP8	830	mW
Soldering Temperature (reflow)		300	°C
Storage Temperature Range		-60~150	°C
Temperature Range		-40~85	°C

Stresses beyond those listed under “Parameter limit” may cause permanent damage to the device. These are stress ratings only and functional operation of the device at these or any other conditions beyond those indicated in the operational sections of the specifications are not implied. Exposure to absolute maximum rating conditions for extended periods may affect device reliability



Receiver Switching Characteristics

Parameter	symbol	Test condition	Minimum	Typical case	Maximum	Unit
Propagation delay from receiver input to output, from low to high	tRPLH	CL=15pF See Figures 7 and 8		80	150	ns
The propagation delay from receiver input to output is from high to low	tRPHL			80	150	ns
tRPLH-tRPHL	tRPDS			7	10	ns
Enable low time out	tRPZL	CL=15pF See Figures 7 and 8		20	50	ns
Enable to output high time	tRPZH	CL=15pF See Figures 7 and 8		20	50	ns
Time from output low to disable	tpRLZ	CL=15pF See Figures 7 and 8		20	45	ns
Time from output high to disable	tpRHZ	CL=15pF See Figures 7 and 8		20	45	ns
Off state Enable to output high time	tRPSH	CL=15pF See Figures 7 and 8		200	1400	ns
Off state Enable low time out	tRPSL	CL=15pF See Figures 7 and 8		200	1400	ns
Time to turn off	tsHDN	NOTE	80		300	ns

NOTE: When /RE=1 and DE=0, the device will not enter shutdown mode if the duration is less than 80ns; however, it will definitely enter shutdown mode if the duration exceeds 300ns



supply current						
Parameter	symbol	Test condition	Minimum	Typical case	Maximum	Unit
Supply current	I <sub>CC1</sub>	/RE=0V,DE=0V		520	800	uA
	I <sub>CC2</sub>	/RE=VCC,DE=VCC		540	700	uA
Turn-off current	I <sub>sHDN</sub>	/RE=VCC,DE=0V		0.5	10	uA
Drive Switch Characterist-ics						
Parameter	symbol	Test condition	Minimum	Typical case	Maximum	Unit
Driver differen-tial output delay	t <sub>DD</sub>	R <sub>DIFF</sub> =60 ,CL <sub>1</sub> =CL <sub>2</sub> =100pF(see Fi-gure 3 and Figure 4)		10	35	ns
Drive differentialoutput transition time	t <sub>TD</sub>			12	25	ns
Drive propagation delay from low to high	t <sub>PLH</sub>	R <sub>DIFE</sub> =27 (see Figure 3 and Figure 4)		8	35	ns
Drive propagationdelay from high to low	t <sub>PHL</sub>			8	35	ns
t <sub>PLH</sub> -t <sub>PHL</sub>	t <sub>PDS</sub>			1	8	ns
Enable to output high	t <sub>pZH</sub>	R <sub>L</sub> =110 (see Figure 5 and 6)		20	90	ns
Enable to output low	t <sub>pZL</sub>			20	90	ns
Input low to disable	t <sub>PLZ</sub>	R <sub>L</sub> =110 (see Figure 5 and 6)		20	80	ns
Enable high input	t <sub>PHZ</sub>			20	80	ns
Enable high outputunder off condition	t <sub>DSh</sub>	R=110 (see Figure 5 and 6)		500	900	ns
Enable low output under shutdown conditions	t <sub>DsL</sub>	R <sub>L</sub> =110 (see Figure 5 and 6)		500	900	ns



DC electrical characteristics of the driver						
Parameter	symbol	Test condition	Minimum	Typical case	Maximum	Unit
Driver differential output (non-loaded)	VoD <sub>1</sub>			3.3		V
Drive differential output	VoD <sub>2</sub>	graph 2,RL=54	1.5		VCC	V
		graph 2,RL=100	2		VCC	
Variation in the amplitude of the output voltage (NOTE1)	VoD	graph 2,RL=54			0.2	V
Output common mode voltage	Voc	graph 2,RL=54			3	V
Amplitude Variation of Common Mode Output Voltage (NOTE1)	Voc	graph 2,RL=54			0.2	V
High-level input	VH	DE,DI,/RE	2.0			V
Low level input	V	DE,DI,/RE			0.8	V
Logic input current	IN1	DE,DI,/RE	-2		2	uA
Output the current during a short circuit, with high short-circuit	I <sub>osD1</sub>	Short circuit to 0V~12V			250	mA
Output the current during a short circuit, down to low	I <sub>osD2</sub>	Short circuit to -7V~0V	-250			mA
Overtemperature shutdown threshold temperature				140		
Overtemperature turn-off hysteresis temperature				20		



DC Electrical Characteristics of the Receiver

Parameter	symbol	Test condition	Minimum	Typical case	Maximum	Unit
Input current(A,B)	IN2	DE=0V,VCC=0 or 3.3V VIn=12V			125	uA
		DE=0V,VCC=0 or 3.3V VIn=-7V	-100			uA
Forward input threshold voltage	VIT+	-7V Vcm 12V			+200	mV
Reverse input threshold voltage	VIT-	-7V Vcm 12V	-200			mV
Input hysteresis voltage	Vhys	-7V Vcm 12V	10	30		mV
High level output voltage	VoH	IoUT=-2.5mA,VID =+200 mV	VCC-1.5			V
Low level output voltage	VoL	IoUT=+2.5mA,VD =-200 mV			0.4	V
Three-state input leakage current	IozR	0.4V<Vo<2.4V			±1	uA
Input resistance of receiver	RIn	-7V Vcm 12V	96			k
Receiver short circuit current	IosR	0V Vo VCC	±8		±60	mA



## FUNCTION TABLES

TRANSMITTING					RECEIVING				
CTR	/RE	X	X	0	1	0	0	0	1
	DE	1	1	0	0	X	X	X	X
INPUTS	DI	1	0	X	X				
	A-B					$\geq -10\text{mV}$	$\leq -200\text{mV}$	Open/shorted	X
OUTPUTS	A	H	L	Z					
	B	L	H	Z					
	RO					H	L	H	Z

X:Don't care;Z:high impedance.

## TEST CIRCUIT

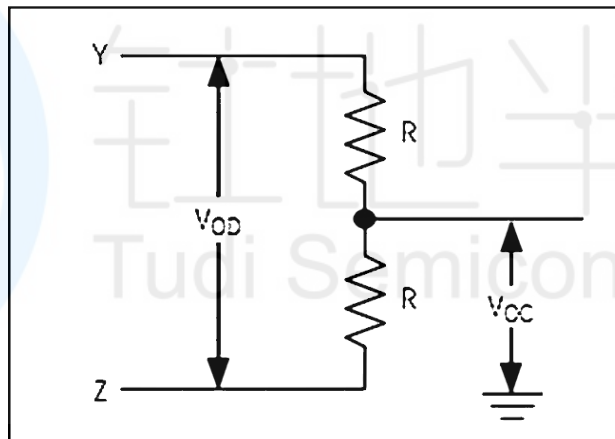

Figure 2 DC test load of the driver

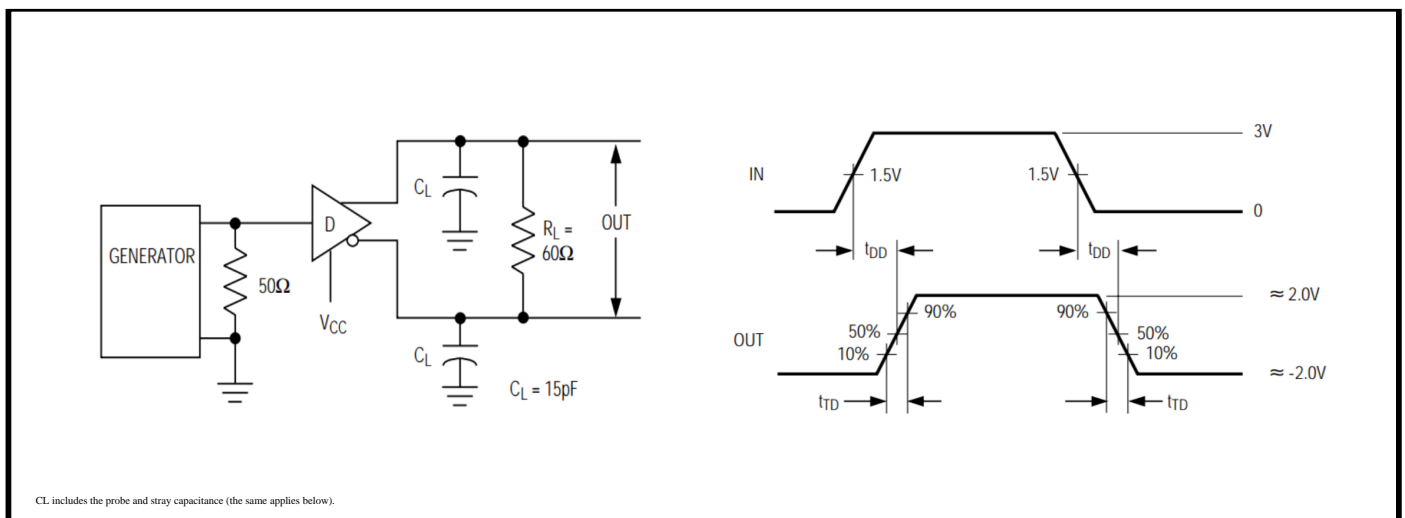

Figure 3 Differential delay and transit time of driver

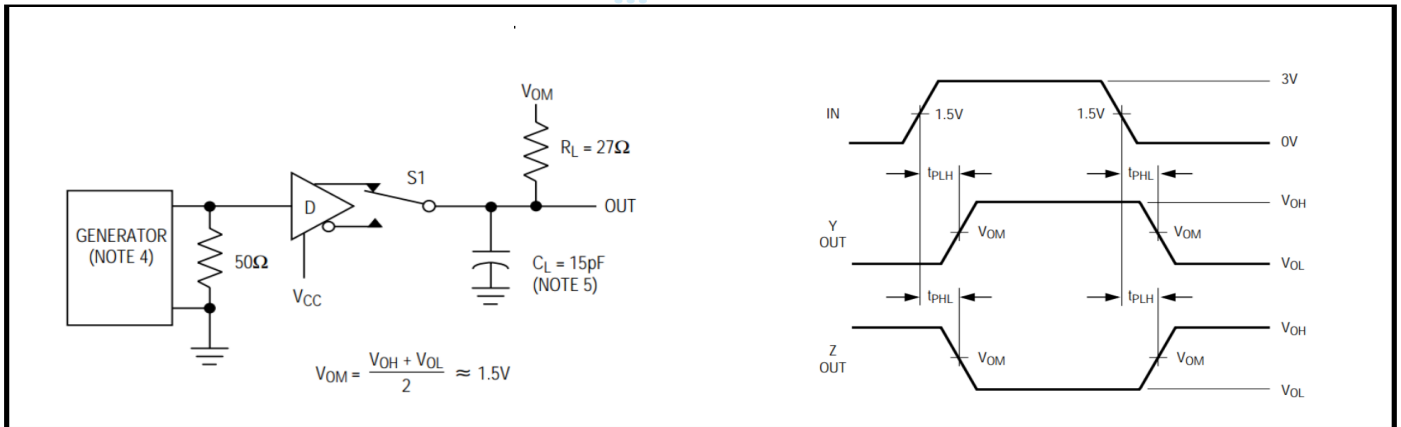

Figure 4 Propagation Delay of Driver

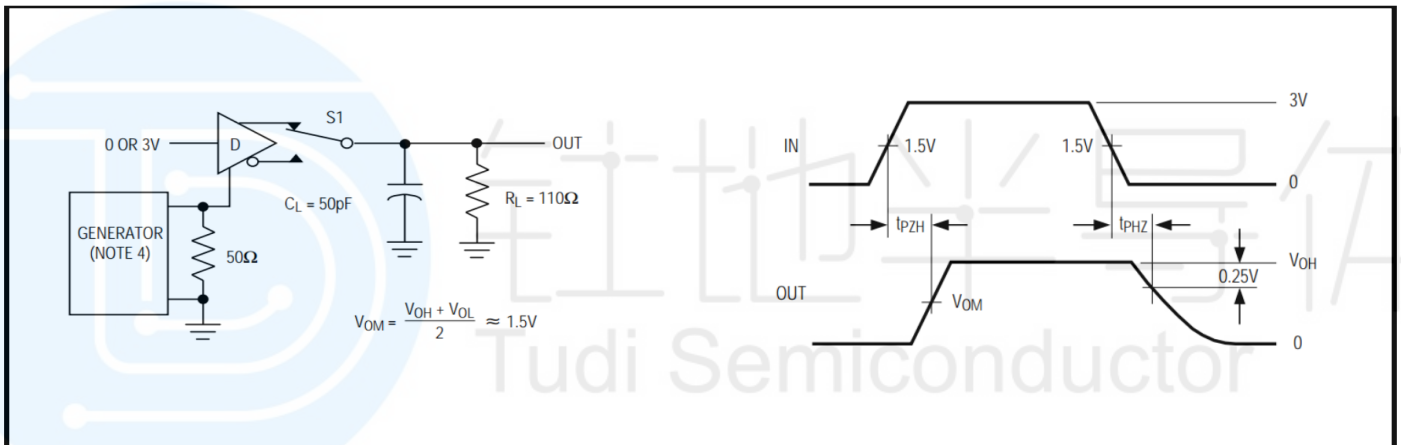

Figure 5 Driver enable and disable time

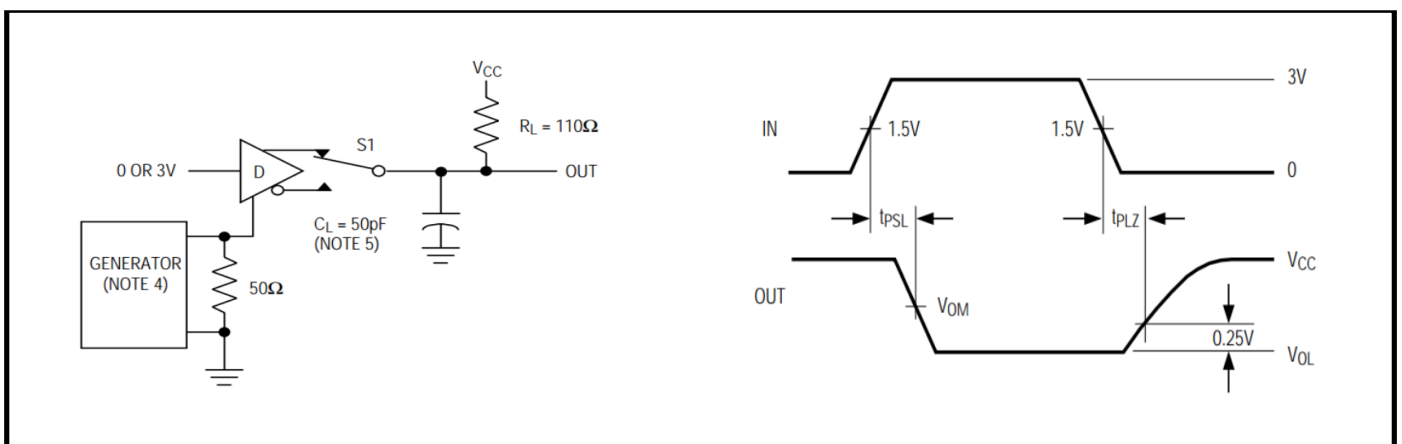

Figure 6 Driver enable and disable time

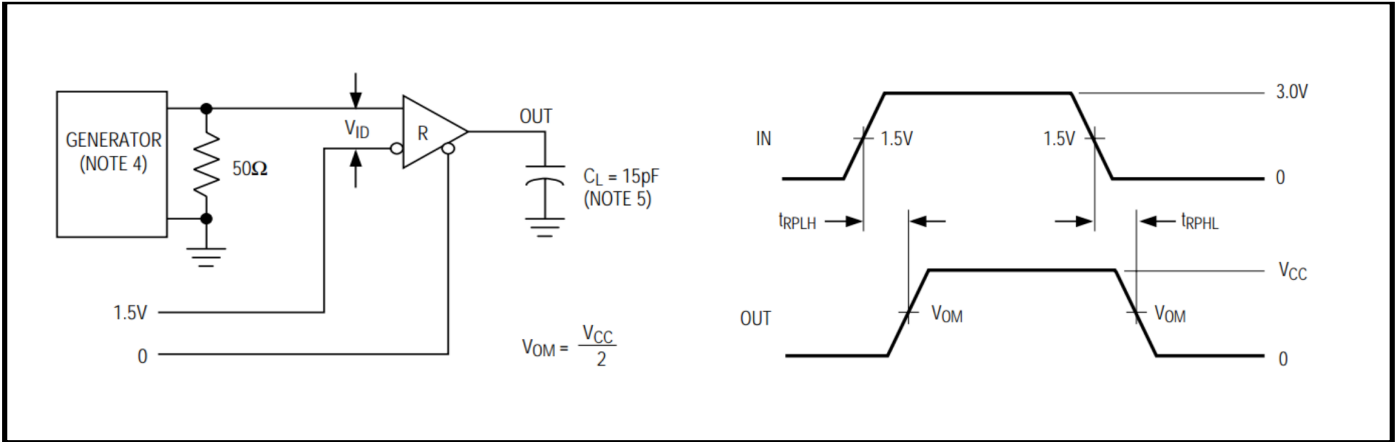

Figure 7 Receiver propagation delay test circuit

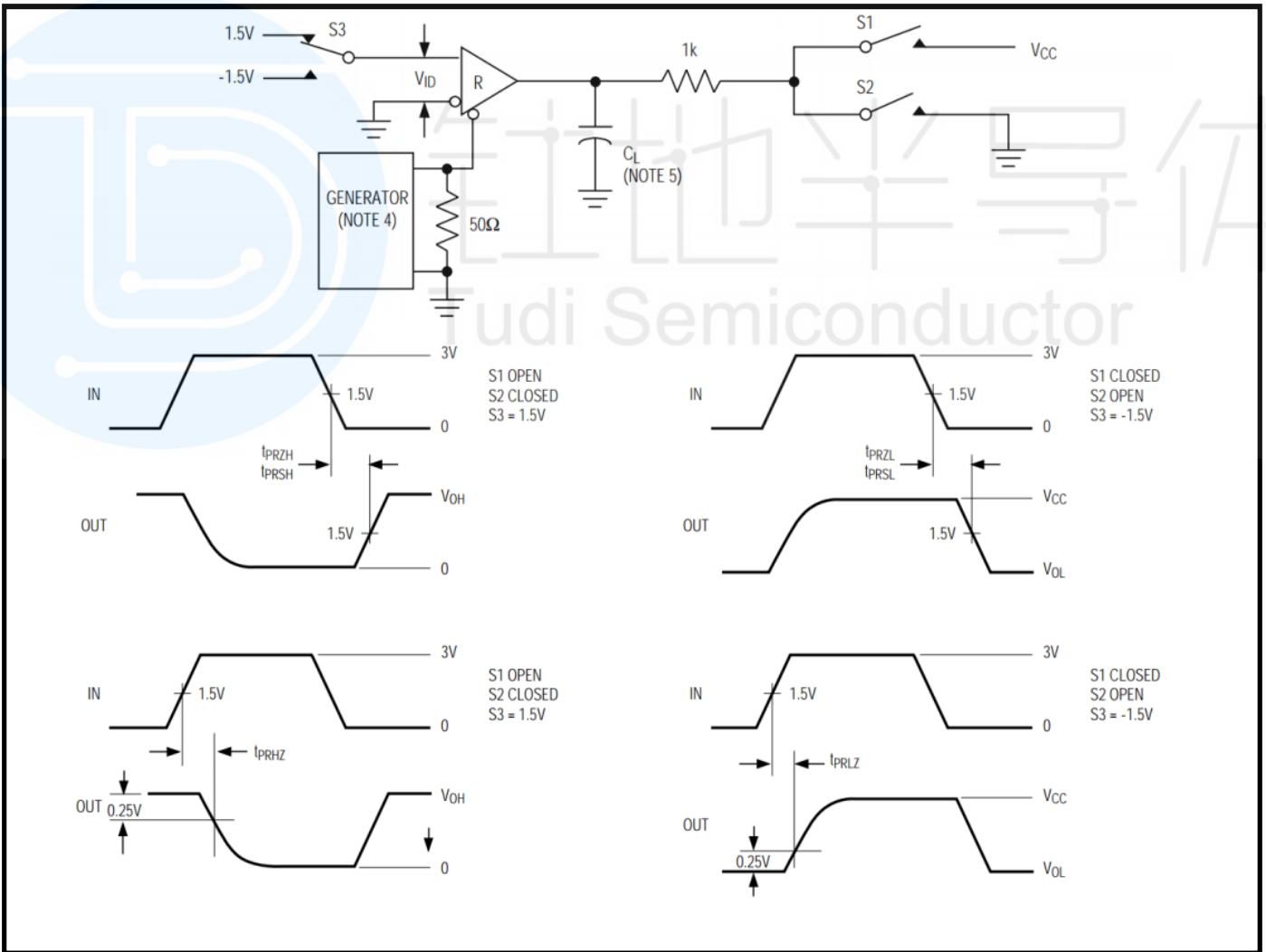

Figure 8 Receiver Enable and Disable Time

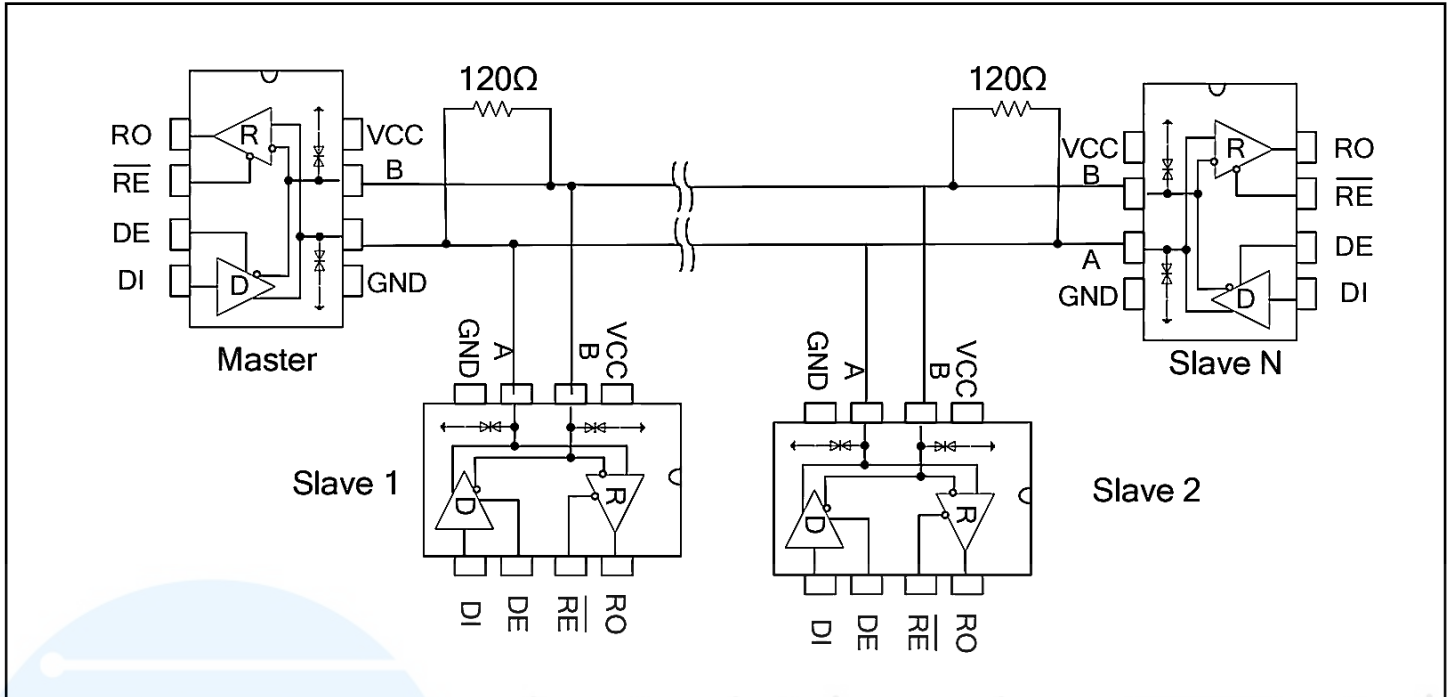

Fig11 Backbone cable type RS485 communications network

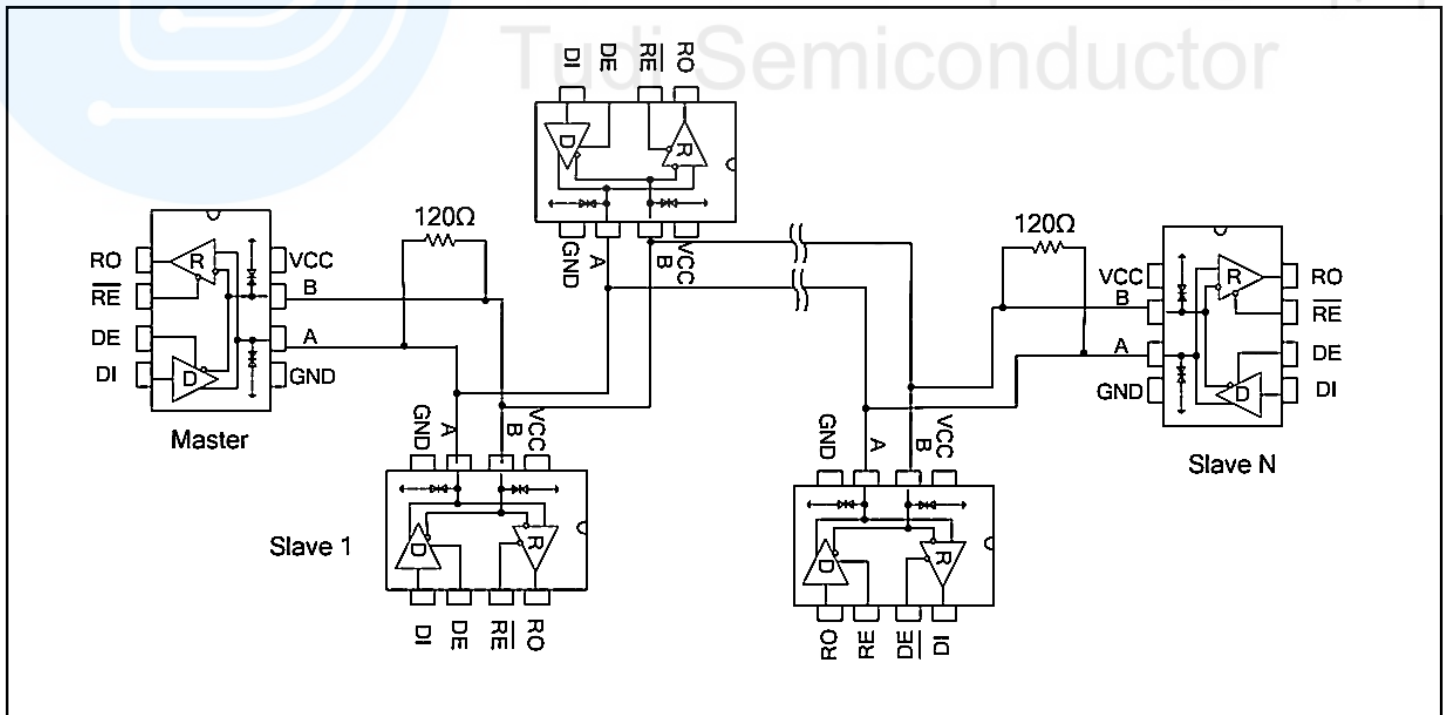

Fig12 Daisy chain topology type RS485 communications network

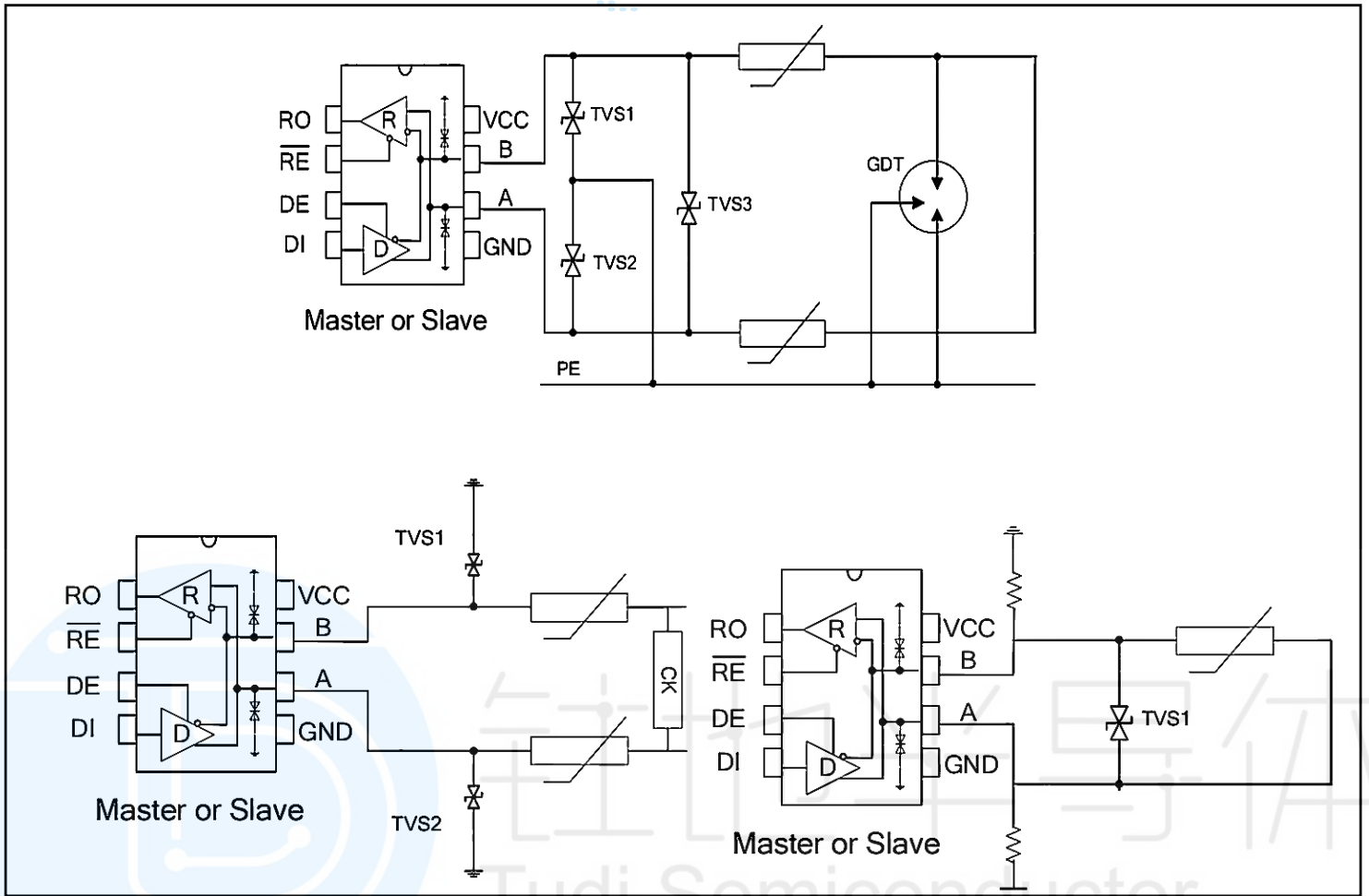

Fig13 RS485 bus ports Protection configuration

## Order information

Order Number	Package	Package Quantity	Marking On The park	Temperature
SN65HVD72DR-TUDI	SOP8	Tape,Reel,2500	HVD72	- 40°C to 125°C
SN65HVD72DGKR-TUDI	MSOP8	Tape,Reel,2500	HVD72	
SN65HVD72P-TUDI	DIP8	Tube,50,A box of 2000	65HVD72	



Package SOP8

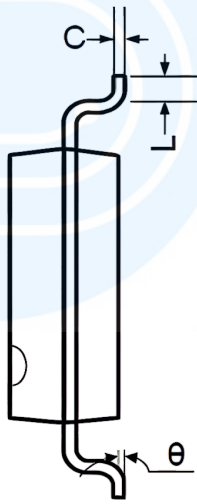
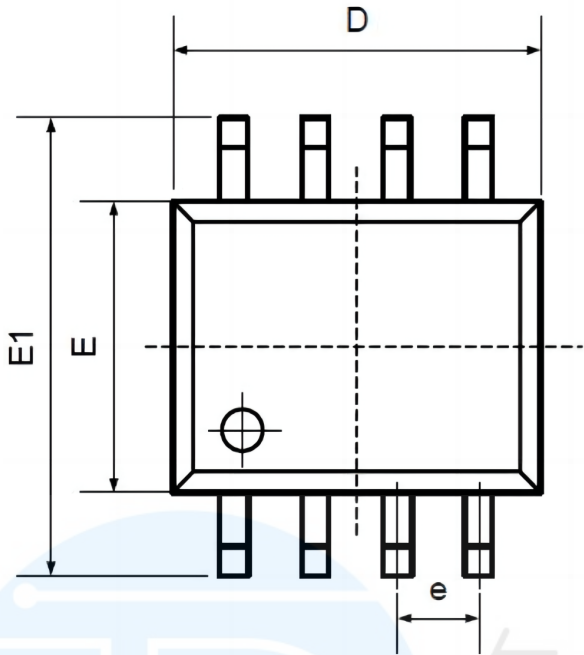

Symbol	Dimensions In Millimeters		Dimensions In Inches	
	Min	Max	Min	Max
A	1.350	1.750	0.053	0.069
A1	0.100	0.250	0.004	0.010
A2	1.350	1.550	0.053	0.061
B	0.330	0.510	0.013	0.020
C	0.190	0.250	0.007	0.010
D	4.780	5.000	0.188	0.197
E	3.800	4.000	0.150	0.157
E1	5.800	6.300	0.228	0.248
e	1.270TYP		0.050TYP	
L	0.400	1.270	0.016	0.050
theta	0°	8°	0°	8°

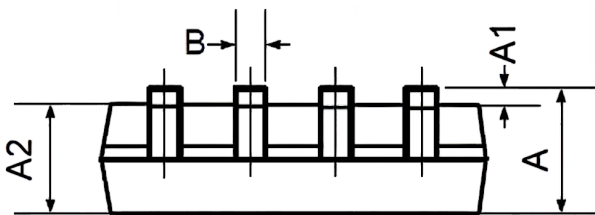



Package MSOP8

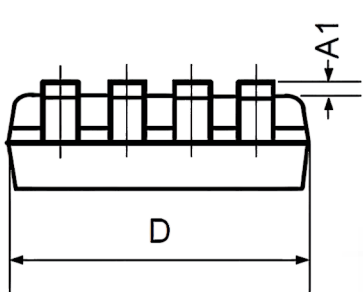
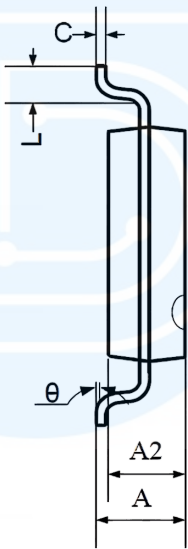
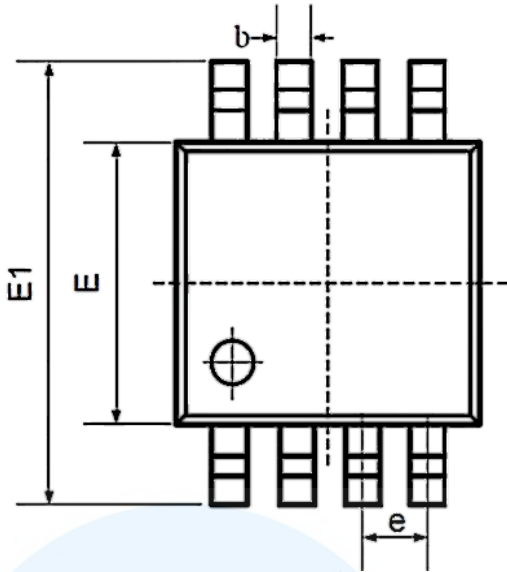

Symbol	Dimensions In Millimeters		Dimensions In Inches	
	Min	Max	Min	Max
A	0.800	1.200	0.031	0.047
A1	0.000	0.200	0.000	0.008
A2	0.760	0.970	0.030	0.038
b	0.30 TYP		0.012 TYP	
C	0.15 TYP		0.006 TYP	
D	2.900	3.100	0.114	0.122
e	0.65 TYP		0.026 TYP	
E	2.900	3.100	0.114	0.122
E1	4.700	5.100	0.185	0.201
L	0.410	0.650	0.016	0.026
θ	0°	6°	0°	6°



Package DIP8

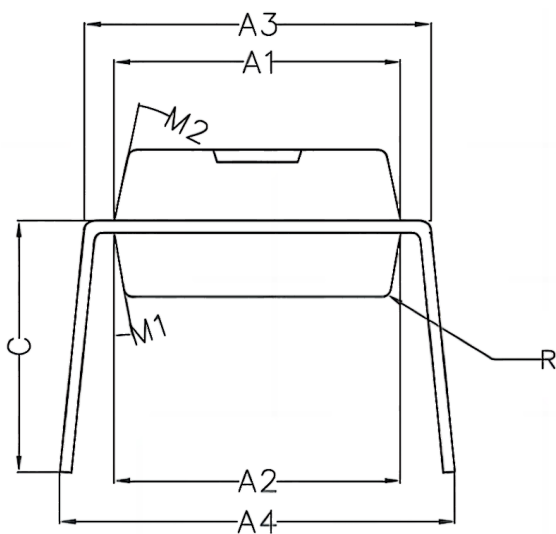
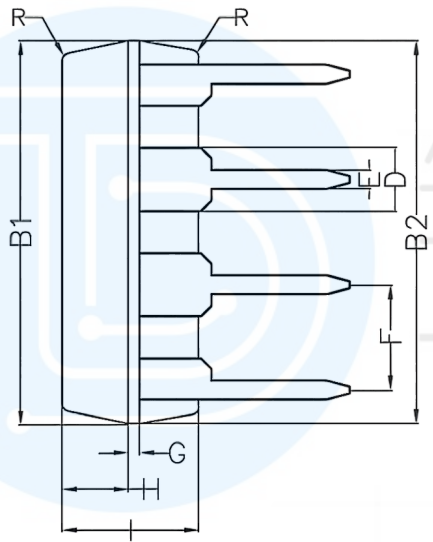
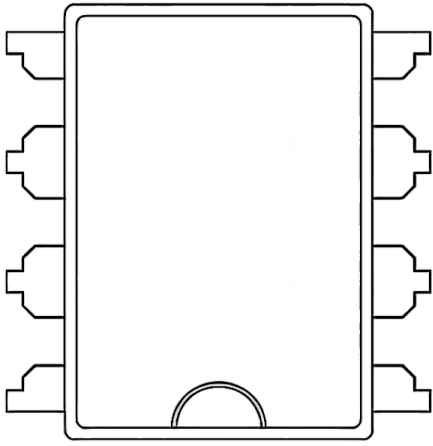

Symbol	Min	Non	Max
A1	6.28	6.33	6.38
A2	6.33	6.38	6.43
A3	7.52	7.62	7.72
A4	7.80	8.40	9.00
B1	9.15	9.20	9.25
B2	9.20	9.25	9.30
C		5.57	
D		1.52	
E	0.43	0.45	0.47
F		2.54	
G		0.25	
H	1.54	1.59	1.64
I	3.22	3.27	3.32
R		0.20	
M1	9°	10°	11°
M2	11°	12°	13°



## Important statement:

- TUDI Semiconductor reserves the right to modify the product manual without prior notice! Before placing an order, customers need to confirm whether the obtained information is the latest version and verify the completeness of the relevant information.
- Any semi-guide product is subject to failure or malfunction under specified conditions. It is the buyer's responsibility to comply with safety standards when using TUDI Semiconductor products for system design and whole machine manufacturing. And take the appropriate safety measures to avoid the potential in the risk of loss of personal injury or loss of property situation!
- TUDI Semiconductor products have not been licensed for life support, military, and aerospace applications, and therefore TUDI Semiconductor is not responsible for any consequences arising from the use of this product in these areas.
- If any or all TUDI Semiconductor products (including technical data, services) described or contained in this document are subject to any applicable local export control laws and regulations, they may not be exported without an export license from the relevant authorities in accordance with such laws.
- The specifications of any and all TUDI Semiconductor products described or contained in this document specify the performance, characteristics, and functionality of said products in their standalone state, but do not guarantee the performance, characteristics, and functionality of said products installed in Customer's products or equipment. In order to verify symptoms and conditions that cannot be evaluated in a standalone device, the Customer should ultimately evaluate and test the device installed in the Customer's product device.
- TUDI Semiconductor documentation is only allowed to be copied without any alteration of the content and with the relevant authorization. TUDI Semiconductor assumes no responsibility or liability for altered documents.
- TUDI Semiconductor is committed to becoming the preferred semiconductor brand for customers, and TUDI Semiconductor will strive to provide customers with better performance and better quality products.