

PDFN5060 Plastic-Encapsulate MOSFETS

Features

- $V_{DS}=60V$
- $I_D=55A$
- $R_{DS(on)}@V_{GS}=10V < 13m\Omega$
- $R_{DS(on)}@V_{GS}=4.5V < 16.5m\Omega$
- High density cell design for ultra low Rdson
- Voltage controlled small signal switch
- Fast Switching Speedze

Drain-source Voltage

60 V

Drain Current

55 Ampere

Applications

- Power Switching Application
- Hard switched and high frequency circuits
- Uninterruptible power supply

Mechanical Data

- Case: PDFN5060
Molding compound meets UL 94V-0 flammability rating, RoHS-compliant,halogen-free
- Terminals: Solder plated, solderable per MIL-STD-750,Method 2026

Function Diagram

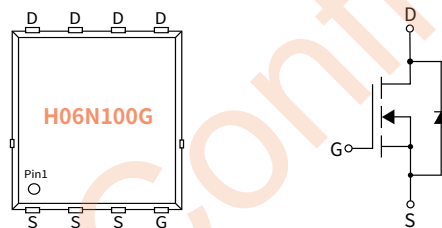

Ordering Information

PACKAGE	PACKAGE CODE	UNIT WEIGHT(g)	REEL(pcs)	BOX(pcs)	CARTON(pcs)	DELIVERY MODE
PDFN5060	R3	0.09	5000	10000	80000	13"

Maximum Ratings (Ta=25°C Unless otherwise specified)

PARAMETER	SYMBOL	UNIT	VALUE
Drain-source Voltage	V_{DS}	V	60
Gate-source Voltage	V_{GS}	V	± 20
Drain Current	I_D	A	55
Pulsed Drain Current ⁽¹⁾	I_{DM}	A	220
Total Power Dissipation	P_D	W	60
Single pulse avalanche energy ⁽²⁾	EAS	mJ	49
Junction temperature	T_J	°C	-55 ~+150
Storage temperature	T_{stg}	°C	-55 ~+150
Thermal Resistance Junction-to-Case	$R_{\theta JC}$	°C / W	2.08

● Static Parameter Characteristics (T_j=25°C Unless otherwise specified)

PARAMETER	SYMBOL	Condition	UNIT	Min	Typ	Max
Drain-Source Breakdown Voltage	BV _{DSS}	V _{GS} = 0V, I _D =250μA	V	60	—	—
Zero Gate Voltage Drain Current	I _{DSS}	V _{DS} =60V, V _{GS} =0V	μA	—	—	1.0
Gate-Body Leakage Current	I _{GSS}	V _{GS} = ±20V, V _{DS} =0V	nA	—	—	±100
Gate Threshold Voltage	V _{GS(th)}	V _{DS} = V _{GS} , I _D =250μA	V	1.0	1.8	2.5
Static Drain-Source On-Resistance ⁽³⁾	R _{DS(ON)}	V _{GS} = 10V, I _D =20A	mΩ	—	10	13
	R _{DS(ON)}	V _{GS} = 4.5V, I _D =10A		—	13	16.5

● Dynamic Parameters

PARAMETER	SYMBOL	Condition	UNIT	Min	Typ	Max
Input Capacitance	C _{iss}	V _{DS} =30V, V _{GS} =0V, f=1MHZ	pF	—	1210	—
Output Capacitance	C _{oss}			—	338	—
Reverse Transfer Capacitance	C _{rss}			—	15	—

● Switching Parameters

PARAMETER	SYMBOL	Condition	UNIT	Min	Typ	Max
Turn-on Delay Time	t _{D(on)}	V _{GS} =10V, V _{DD} =30V, I _D =20A, R _{GEN} =3Ω	nS	—	7	—
Turn-on Rise Time	t _r		nS	—	4	—
Turn-off Delay Time	t _{D(off)}		nS	—	23	—
Turn-off fall Time	t _f		nS	—	4	—
Total Gate Charge	Q _g	V _{DS} =30V, I _D =20A V _{GS} =10V	nC	—	16	—
Gate-Source Charge	Q _{gs}		nC	—	3	—
Gate-Drain Charge	Q _{gd}		nC	—	4	—

● Driian-Source Diode Characteristics

PARAMETER	SYMBOL	Condition	UNIT	Min	Typ	Max
Diode Forward Voltage	V _{SD}	I _S =55, V _{GS} =0V	V	—	—	1.2
Maximum Body-Diode Continuous Current	I _S	—	A	—	—	55
Reverse Recovery Time	V _{rr}	I _S =55A, di/dt=100A/us, T _J =25°C	nS	—	20	—
Reverse Recovery Charge	Q _{rr}		nC	—	64	—

Note:

(1) Repetitive Rating: Pulse width limited by maximum junction temperature.

(2) EAS condition : T_j=25°C, V_{DD}=30V, V_G=10V, L=0.5mH, I_{AS}=14A, R_G=25Ω.

(3) Pulse Test: Pulse Width ≤ 300μs, Duty Cycle ≤ 2%.

● Ratings And Characteristics Curves (Ta=25°C Unless otherwise specified)

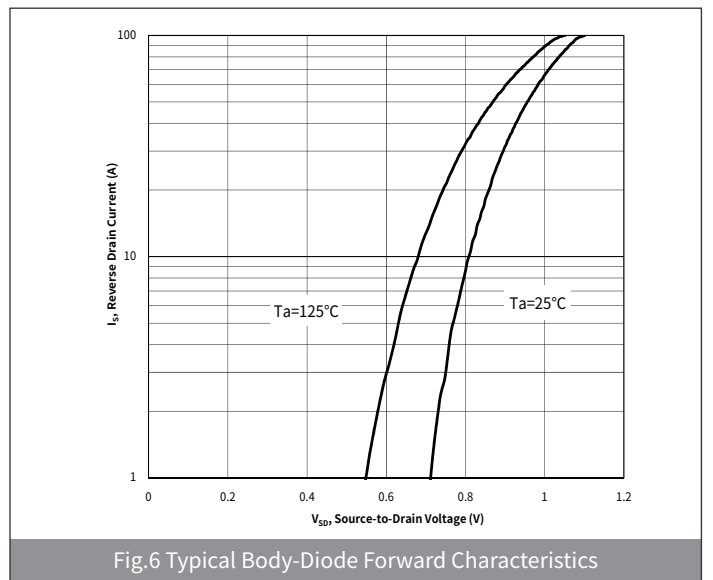
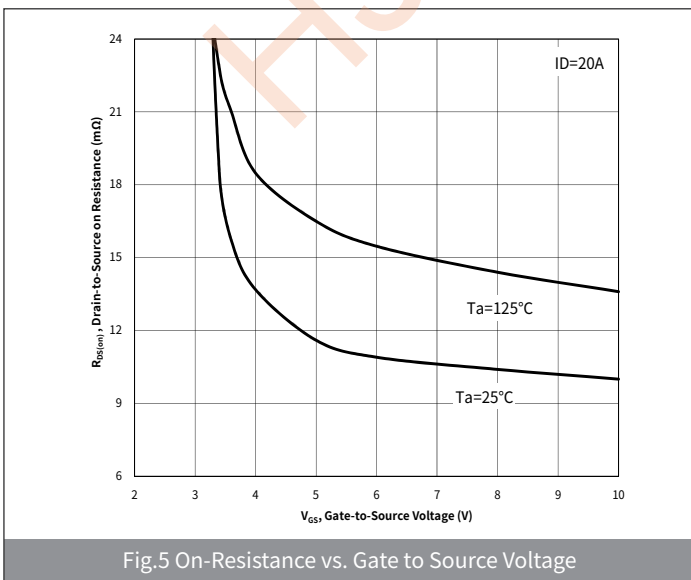
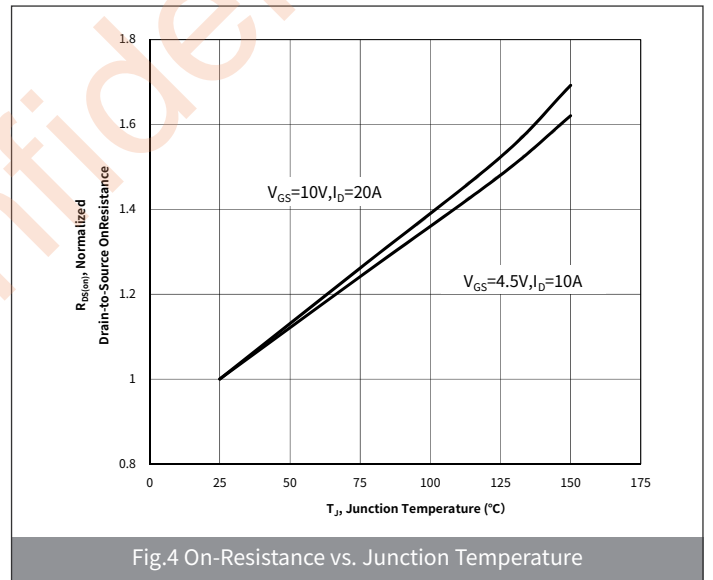
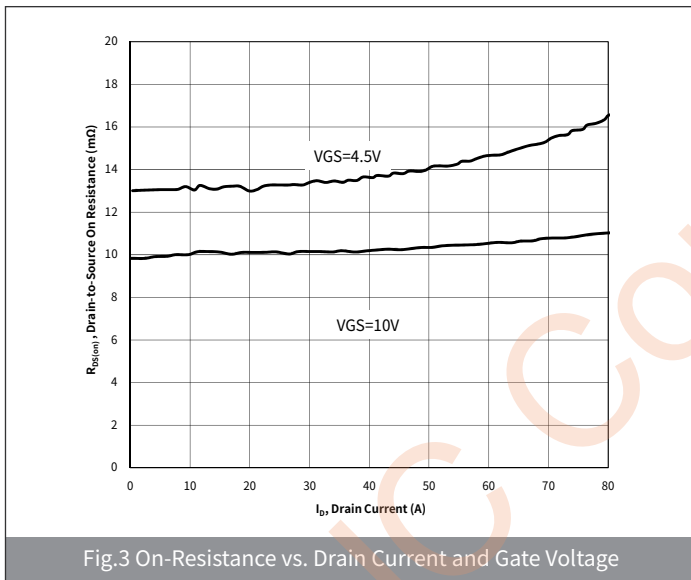
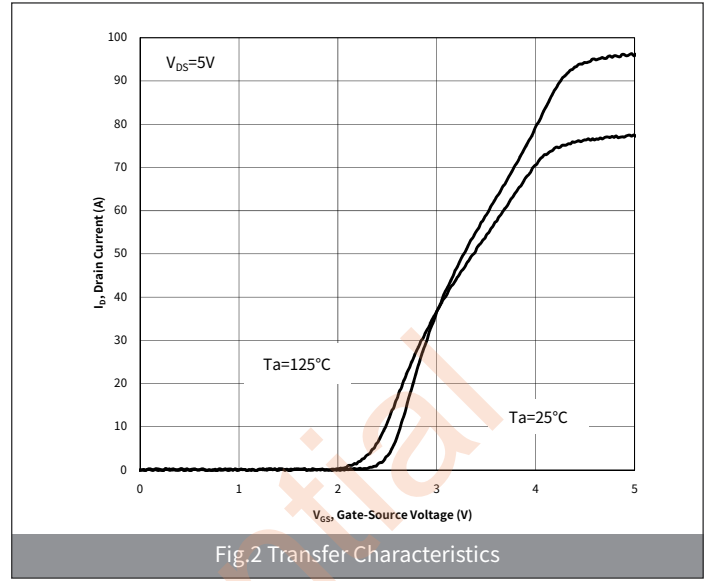
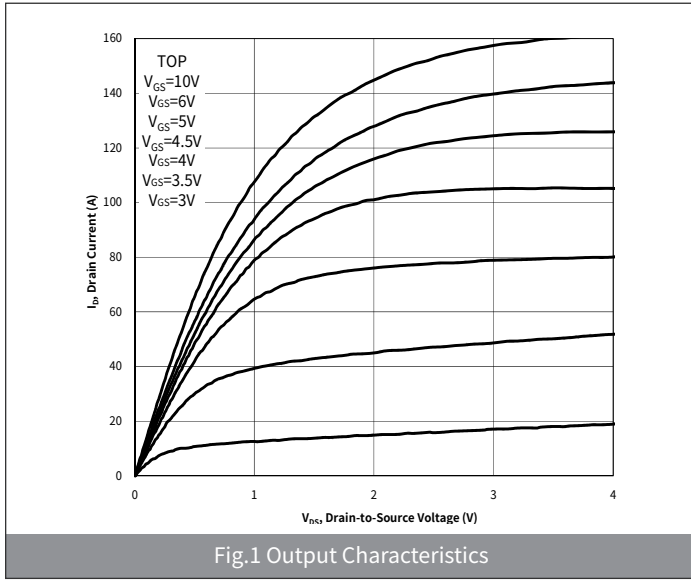

● Ratings And Characteristics Curves (Ta=25°C Unless otherwise specified)

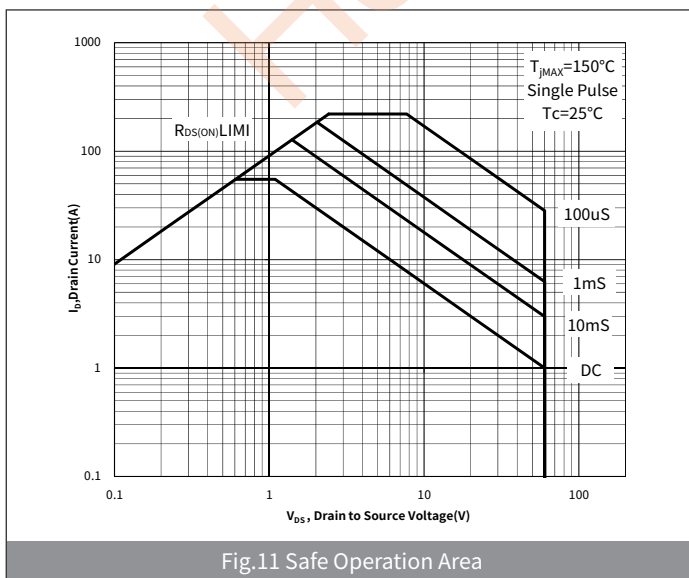
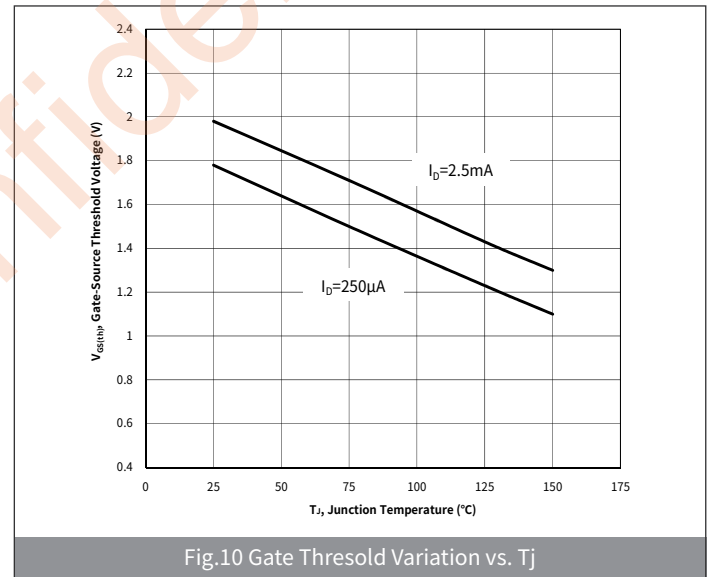
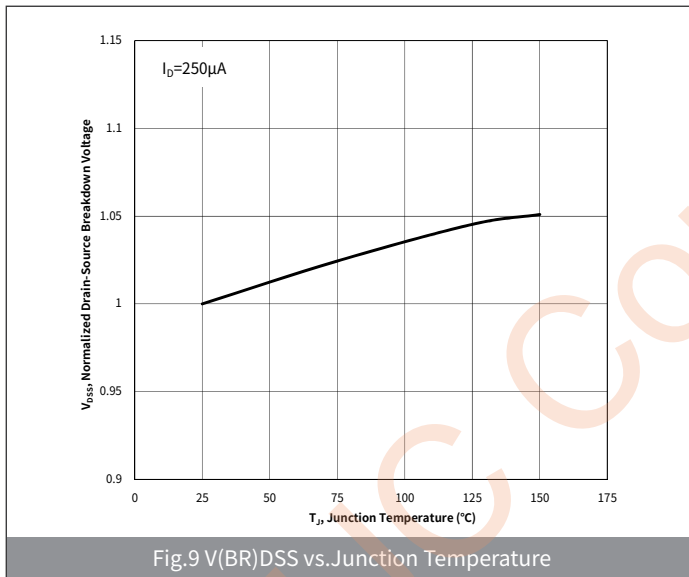
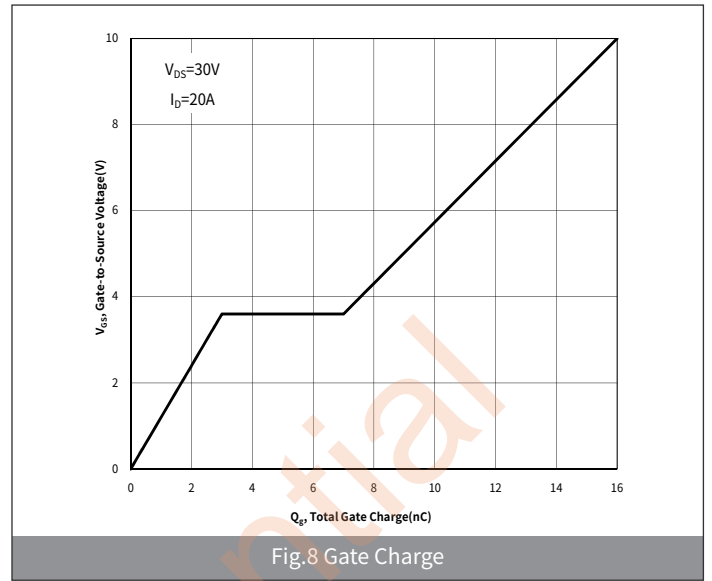
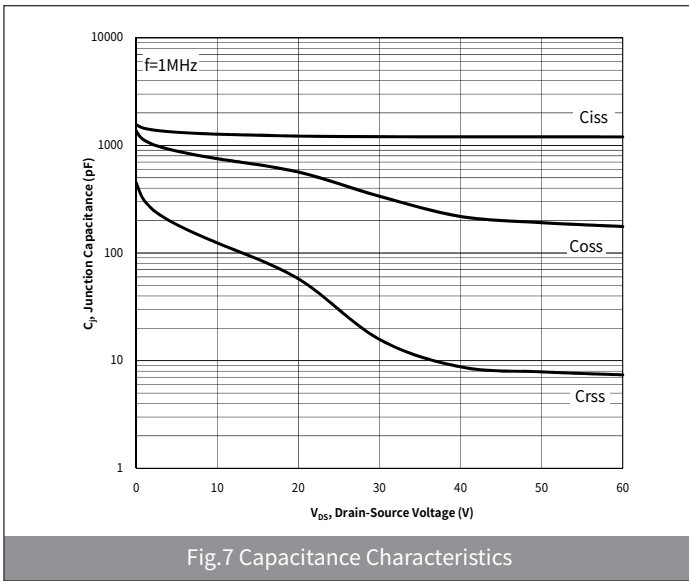

● Ratings And Characteristics Curves (Ta=25°C Unless otherwise specified)

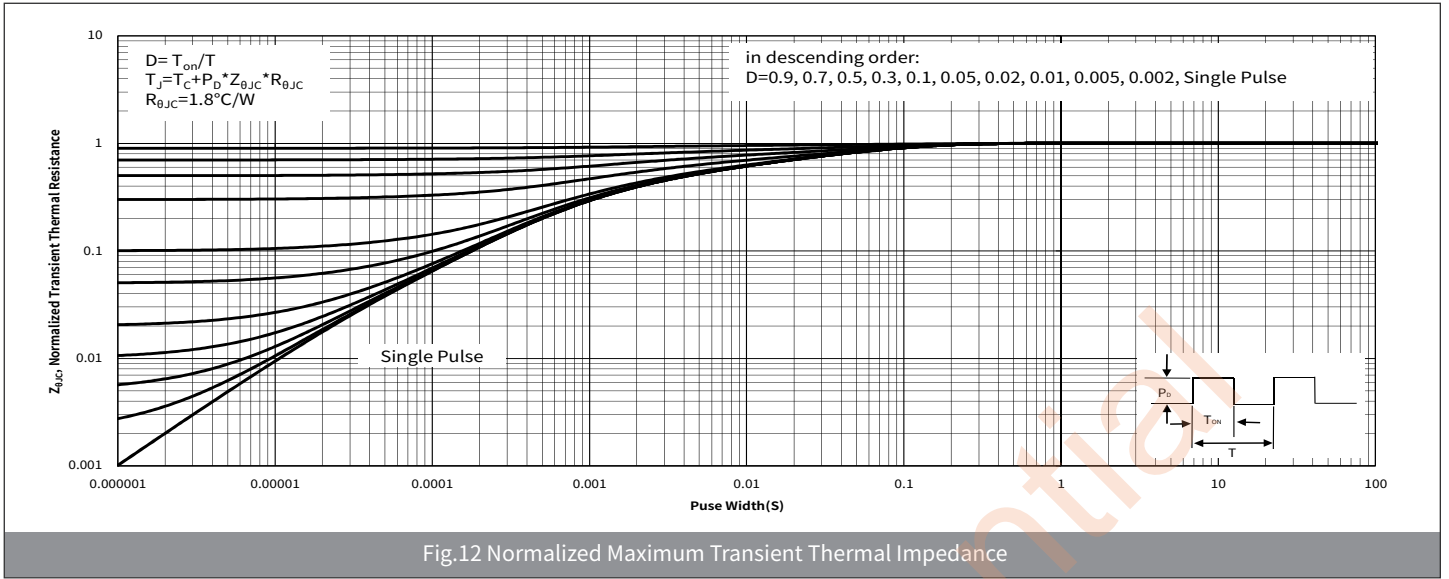

● Package Outline Dimensions (PDFN5060)

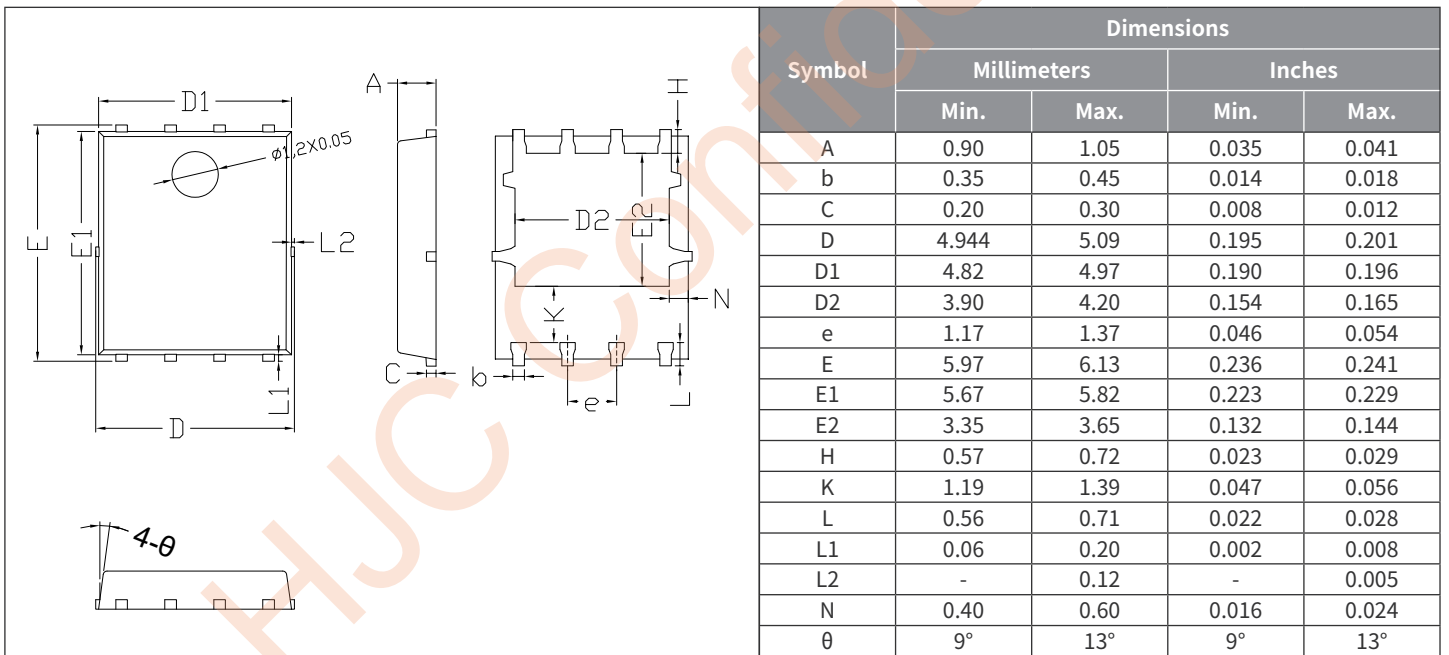

● Suggested Pad Layout

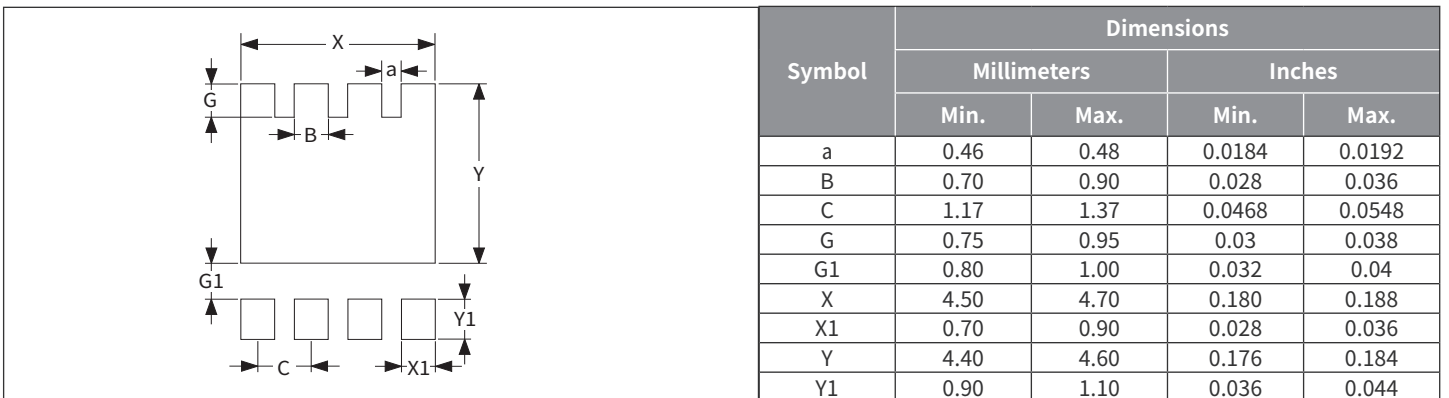

1. Gate Charge Test Circuit & Waveforms

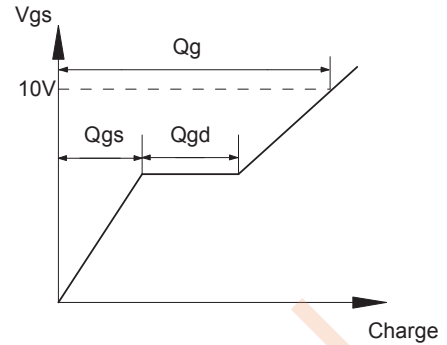
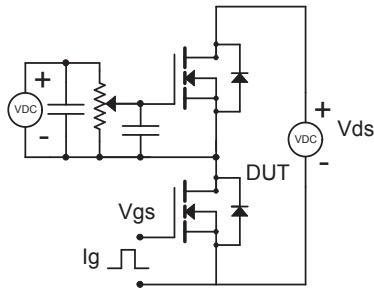

2. Resistive Switching Test Circuit & Waveforms

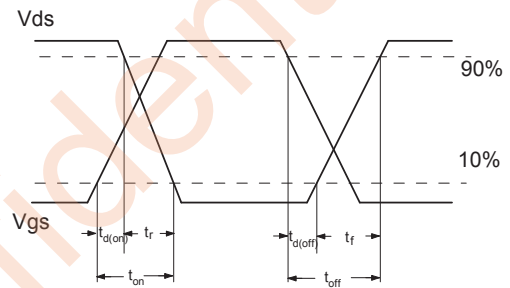
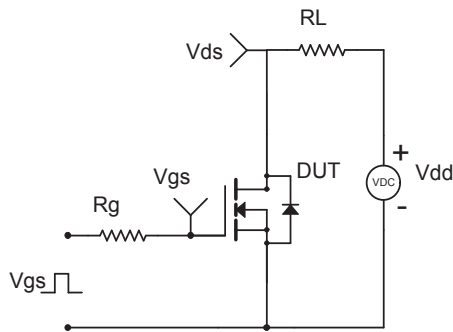

3. Unclamped Inductive Switching (UIS) Test Circuit & Waveforms

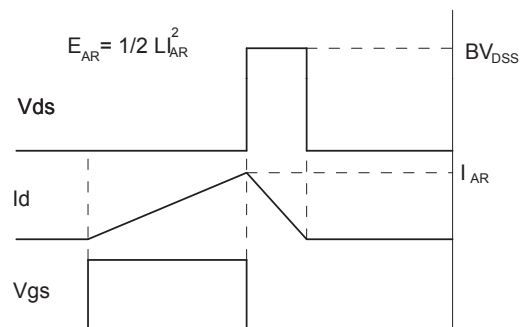
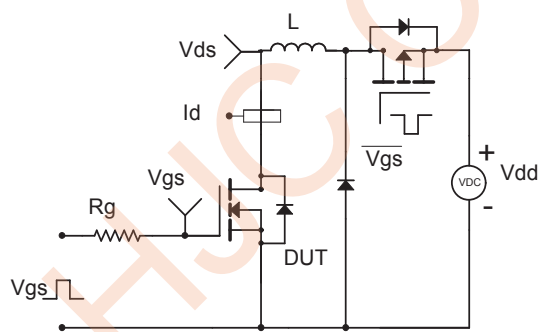

4. Diode Recovery Test Circuit & Waveforms

