



钰地半导体  
Tudi Semiconductor

Tudi Semiconductor

## Product Specification

TUDI-SN65ALS180/SN75ALS180

Low power RS-485 line driver and receiver pair

网址 [www.sztdbdt.com](http://www.sztdbdt.com) 🔍

**用芯智造 · 卓越品质**

**semiconductor device  
manufacturer**

- Design
- research and development
- production
- and sales



## Features

- Complies with or exceeds requirements of TIA/EIA-422, TIA/EIA-485
- High-speed advanced low-power Schottky circuitry
- Designed for 25Mbaud operation in both serial and parallel applications
- Low device--device delay: 6ns (max)
- Low power supply current requirement: 30 mA (max)
- Independent drivers and receivers with separate I/pins for dual VCC and dual GND
- Wide  $\pm$ input/output bus voltage range
- Driver output capability:  $\pm 60\text{mA}$
- Driver current limiting
- Driver input impedance: 12k minimum
- Receiver input sensitivity:  $\pm 200\text{mV}$  (max)
- Receiver input hysteresis: 6 mV (typ)
- Operates from a single 5V power supply

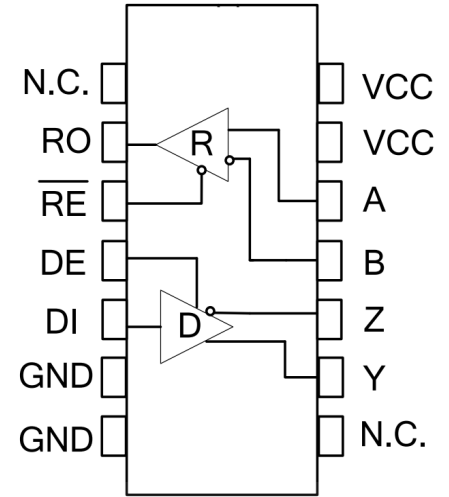

Figure 1 Pin diagram

## Description

The SN65ALS180 and SN75ALS180 differential driver and receiver pairs are integrated circuits designed for bidirectional data on multipoint bus transmission lines. These devices are designed for balanced transmission lines and comply with TIA/EIA-422, TIA/EIA-485.

The SN65ALS180 and SN75ALS180 integrate a three-state differential line driver and a differential input line receiver, both powered by single 5V supply. The driver and receiver have separate high-level and low-level active enable inputs, which can be connected together externally to function as direction control. The differential outputs and the receiver differential inputs are connected to separate termination to achieve greater flexibility, and these ports are used to provide a minimum load to the bus when the driver is disabled or  $\text{CC} = 0$ .

These ports have a positive and negative wide common mode voltage range, making the device well suited for common mode applications



## Pin description

Pin number	Pin name	Pin function
1	NC	No internal connections required
2	RO	Receiver output. When RE is low, the RO output is high if A-B is $-10\text{mV}$ , and low if A-B is $-200\text{mV}$ .
3	/RE	Receiver output enable control. When /RE is low, the receiver output is enabled and RO is active; when /RE is high, the receiver output is disabled and RO is in high-impedance state. When RE is at a high level and DE is at a low level, the device enters low-power shutdown mode
4	DE	The driver output enables the control. When DE is at high level, the driver outputs effectively; when DE is low, it outputs high-impedance state. When /RE is high and DE is low, the device enters low-power shutdown mode.
5	DI	DI driver input. When DE is high, the low level on DI makes the in-phase output A of the driver low and the in-phase output B high; the high level on DI makes the in-phase output high and the in-phase output B low.
6	GND	Landing
7	GND	Landing
8	NC	No internal connections required
9	Y	Driver in-phase output terminal
10	Z	Driver inverting output
11	B	Receiver inverting input
12	A	Receiver in phase input
13	VCC	This pin can be connected to power or left unconnected
14	VCC	Power connection



## Extreme parameter

Parameter	Symbol	Unit	size
Continuous power consumption	SOP14	mW	600
	DIP14	mW	700
Power supply voltage	VCC	V	+7
working temperature range			-40~125
Storage temperature range			-60~150
Welding temperature range			300
Control port voltage	DI	V	-0.3~VCC+0.3
Bus side input voltage	A、B	V	-8~13
Receiver output voltage	RO	V	-0.3~VCC+0.3

The maximum limit parameters are values beyond which the device can be damaged in an irreversible manner. Operation of the device under these conditions is not intended to be normal and may affect the reliability of the device if operated continuously at the maximum rated limit. All voltages are referenced to ground.

### ESD Protect

Parameter	symbol	Test condition	Minimum	Typical case	Maximum	Unit
A、B、Y、Z		Human bodymodel		±15		KV
Other ports		Human bodymodel		±6		KV



Receiver Switching Characteristics

Parameter	symbol	Test condition	Minimum	Typical case	Maximum	Unit
Acceptor	tRPLH	See Figure 7 and Figure 8	20	60	90	ns
Input to output propagation delay from low to high						
The propagation delay from receiver input to output is from high to low	tRPHL	V <sub>I</sub> 2.0V; rising and falling edge time V <sub>I</sub> D 15ns	20	60	90	ns
tRPLH-tRPHL	tsKEW2			7	10	ns
Enable low time out	tRPZL	CL=15pF See Figures 7 and 8		20	50	ns
Enable to output high time	tRPZH	CL=15pF See Figures 7 and 8		20	50	ns
Time from output low to disable	tpRLZ	CL=15pF See Figures 7 and 8		20	45	ns
Time from output high to disable	tpRHZ	CL=15pF See Figures 7 and 8		20	45	ns
Off state Enable to output high time	tRPSH	CL=15pF See Figures 7 and 8		200	1400	ns
Off state Enable low time out	tRPSL	CL=15pF See Figures 7 and 8		200	1400	ns
Time to turn off	tsHDN	NOTE2	80		300	ns

(If not otherwise, VCC=3V~5.5V, Temp = TMIN ~ TMAX, typical value at Temp = 25 ) NOTE 1: ? V<sub>O</sub> D and ? V<sub>O</sub> C is the change in V<sub>O</sub> D and V<sub>O</sub> C amplitude caused when the DI state of the input signal changes, respectively.



DC electrical characteristics of the driver

Parameter	symbol	Test condition	Minimum	Typical case	Maximum	Unit
Driver differential output (non-loaded)	VoD <sub>1</sub>			4.5	VCC	V
Drive differential output	VoD <sub>2</sub>	graph 2, RL=27	1.5	2.3	VCC	V
		graph 2, RL=50	2	2.8	VCC	
Variation in the amplitude of the output voltage (NOTE1)	VoD	graph 2, RL=27			0.2	V
Output common mode voltage	Voc	graph 2, RL=27			3	V
Amplitude Variation of Common Mode Output Voltage (NOTE1)	Voc	graph 2, RL=27			0.2	V
High-level input	VH	DI	2.0			V
Low level input	V	DI			0.8	V
Logic input current	IN1	DI	-2		2	uA
Output the current during a short circuit, with high short-circuit	IosD <sub>1</sub>	Short circuit to 0V~12V	35		250	mA
Output the current during a short circuit, down to low	IosD <sub>2</sub>	Short circuit to -7V~0V	-250		-35	mA

(If not otherwise, VCC=3V~5.5V, Temp = TMIN ~ TMAX, typical value at Temp = 25 ) NOTE 1: VO D and? VOC is the change in VOD and VOC amplitude caused when the DI state of the input signal changes, respectively.



drive switch characteristics

Parameter	symbol	Test condition	Minimum	Typical case	Maximum	Unit	
Input to output propagation delay (low to high)	tDPLH	RD <sub>DIFF</sub> =54 Ω, CL=100pF (see Figure 3 and Figure 4)		12	35	ns	
Input to output propagation delay (high to low)	tDPHL			12	35	ns	
tDPLH-tDPHL	tsKEW1				6	10	ns
Rise time /fall time	tDR,tDF				9	25	ns
Enable to high output	tpZH	R=110 Ω (see Figure 5 and 6)		20	90	ns	
Enable to output low	tpZL			20	90	ns	
Input low to disable	tpLZ	R=110 Ω (see Figure 5 and 6)		20	80	ns	
Enable high input	tpHZ			20	80	ns	
Enable high output under off condition	tDSH	R=110 Ω (see Figure 5 and 6)		500	900	ns	
Enable low output under shutdown conditions	tDSL	RL=110 Ω (see Figure 5 and 6)		500	900	ns	

Supply Current

Parameter	symbol	Test condition	Minimum	Typical case	Maximum	Unit
Supply current	I <sub>cc1</sub>	/RE=0V, DE=0V		220	400	uA
	I <sub>cc2</sub>	/RE=VCC, DE=VCC		240	400	uA
Turn-off current	I <sub>sHDN</sub>	/RE=VCC, DE=0V		0.5	10	uA



DC Electrical Characteristics of the Receiver

Parameter	symbol	Test condition	Minimum	Typical case	Maximum	Unit
Input current(A,B)	IN2	VCC=0 or 3.3V VIN=12V			125	uA
		VCC=0 or 3.3V VIN=-7V	-100			uA
Forward input threshold voltage	VIT+	-7V Vcm 12V			-10	mV
Reverse input threshold voltage	VIT-	-7V Vcm 12V	-200			mV
Input hysteresis voltage	Vhys	-7V Vcm 12V	10	30		mV
High level output voltage	VoH	IoUT=-4mA, VID=+200 mV	VCC-1.5			V
Low level output voltage	VoL	IoUT=+4mA, VID=-200 mV			0.4	V
Three state input leakage current	IozR	0.4V<Vo<2.4V			±1	uA
Input resistance of receiver	RIN	-7V VcM 12V	96			k
Receiver short circuit current	IosR	0V Vo VCC	±7		±95	mA



## Function table

Receiving function table			
control		input	output
/RE	DE	A-B	RO
0	X	$\geq -10\text{mV}$	H
0	X	$\leq -200\text{mV}$	L
0	X	Open/short circuit	H
1	X	X	Z

X: any level; Z: high impedance.

Send function table				
control		input	output	
/RE	DE	DI	Y	Z
X	1	1	H	L
X	1	0	L	H
0	0	X	Z	Z
1	0	X	Z(shutdown)	

X: any level; Z: high impedance.

## Additional description

### Introduction

The ALS180 is a full-duplex high-speed transceiver for RS-485/RS-42 communication, containing a driver and a receiver. It has fail-safe, overvoltage protection, and overcurrent protection. The ALS180 achieves error-free transmission up to 12Mbps.

### fail-safe

The ALS180 guarantees a logic high receiver output if the receiver input is short-circuited or open-circuited, or drivers connected to the terminated transmission line are disabled (idle). This is achieved by setting the receiver input thresholds to  $-10\text{mV}$  and  $-20\text{mV}$ , respectively. RO is logic high if the differential receiver input voltage  $(A-B) \geq -10\text{mV}$ , and RO is logic low if the voltage  $(A-B) \leq -200\text{mV}$ . Logic high with a minimum noise margin of  $50\text{mV}$  can be realized depending on the receiver thresholds. The  $-10\text{mV}$  to  $-200\text{mV}$  threshold voltage is in accordance with the EIA/TIA-485 of  $\pm 200\text{mV}$ .

### 256 transceivers on the bus

The input impedance of the standard RS485 receiver is  $12\text{k}\Omega$  (1 unit load), and the standard driver can drive to 32 unit loads. The receiver of the ALS180 transceiver has an input impedance of  $1/8$  unit load ( $96\text{k}\Omega$ ), allowing up to 256 transceivers to be connected in parallel on the same communication bus. These devices can be combined arbitrarily, or combined with other 485 transceivers, as long as the total load does not exceed 256 unit loads, they can be connected to the same bus.

### Drive output protection

Protection against excessive output current and dissipation by fault or bus contention is provided by overcurrent and overvoltage protection mechanisms, with fast short-circuit throughout the common-mode voltage range (see Typical Operating Characteristics).

## Test circuit

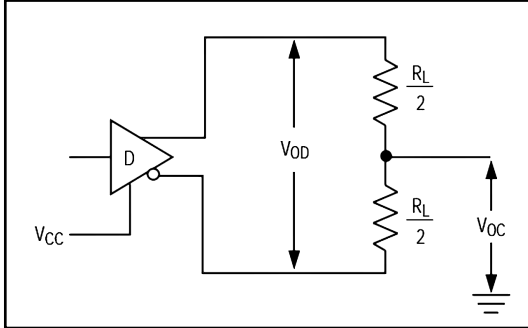

Figure 2: DC test load for the drive

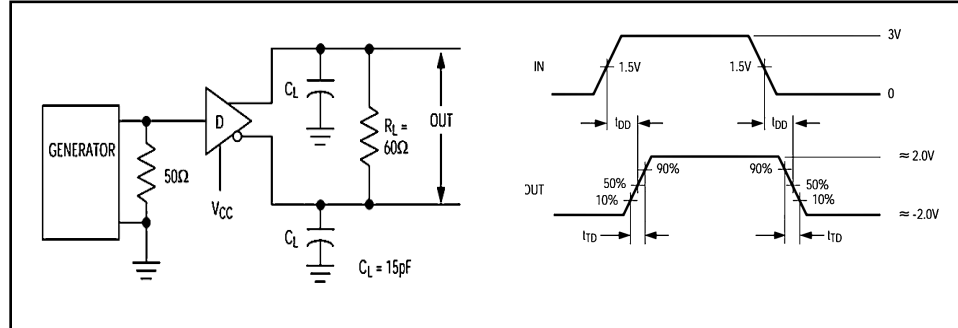

Figure 3 Drive-line Differential Delay and Transit Time

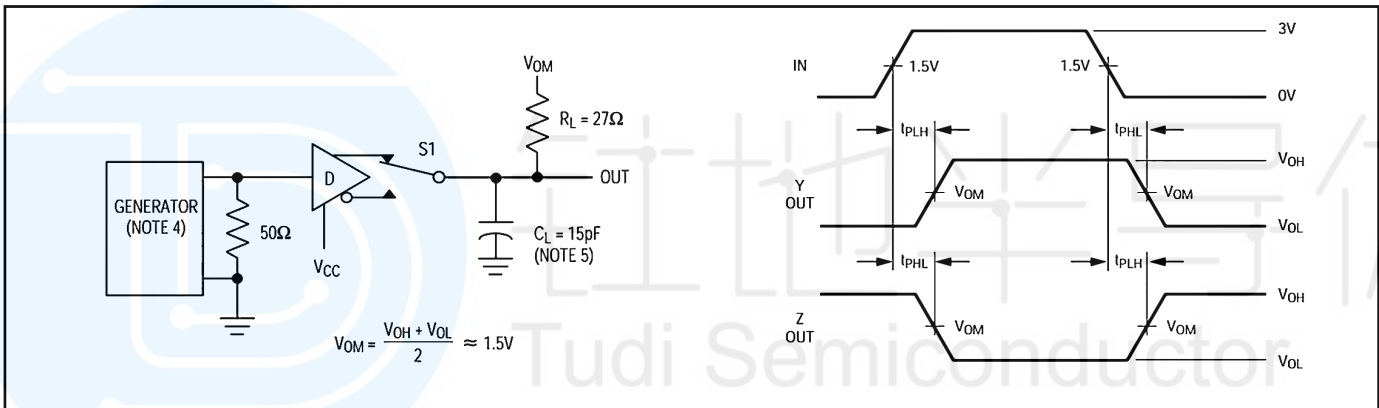

Figure 4 Drive propagation delay

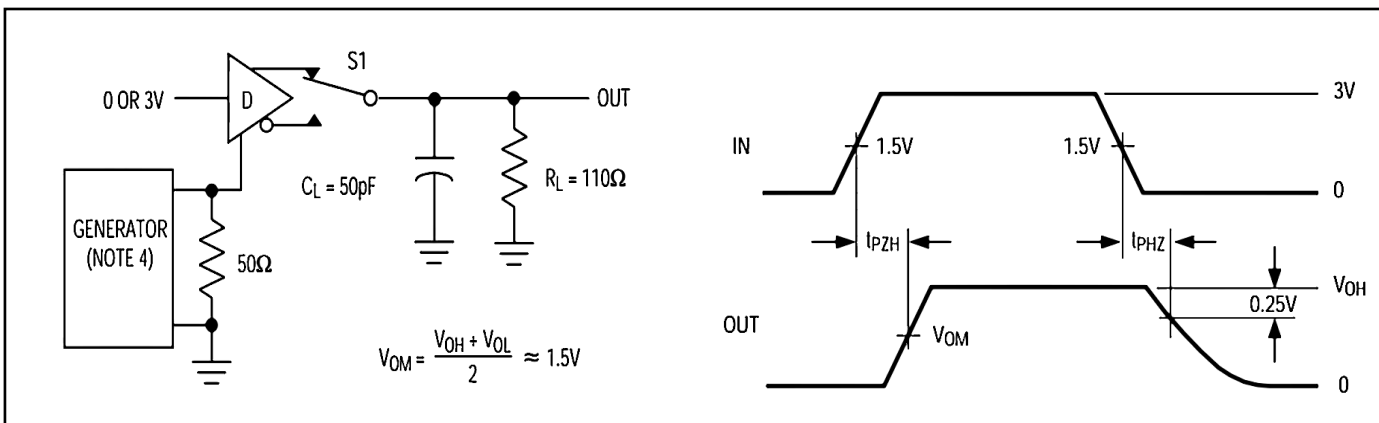

Figure 5 Drive enable and disable time

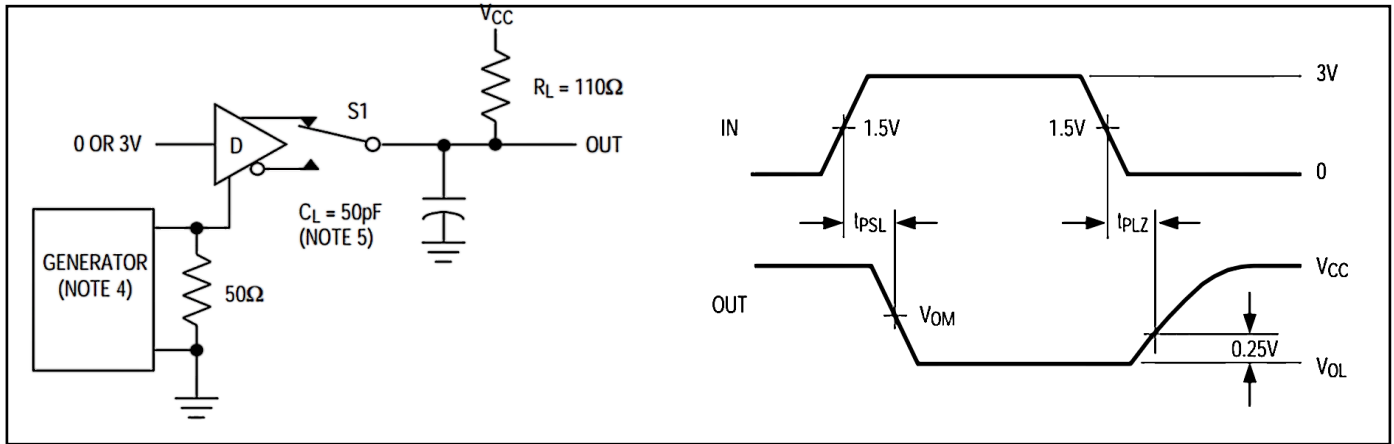

Figure 6 Drive enable and disable time

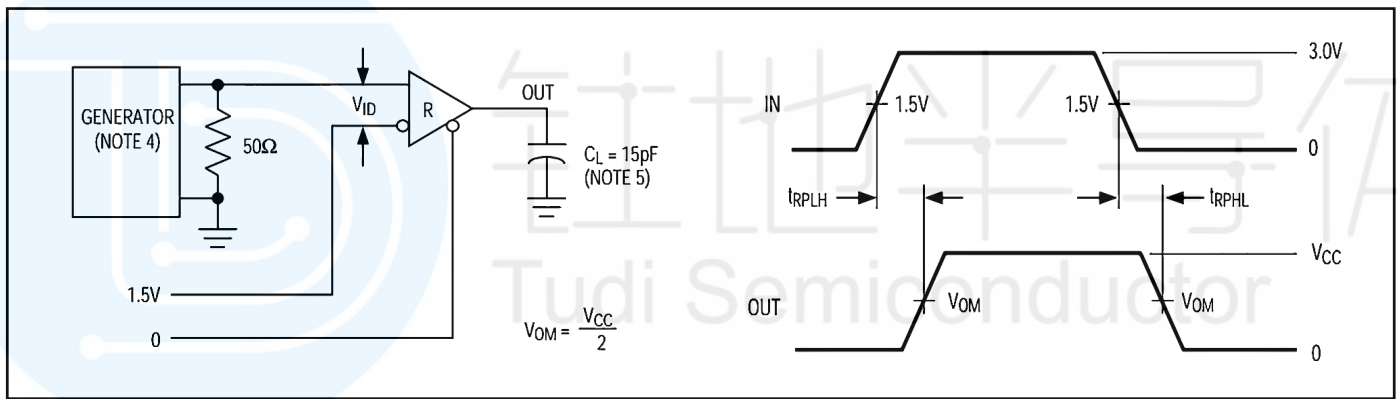
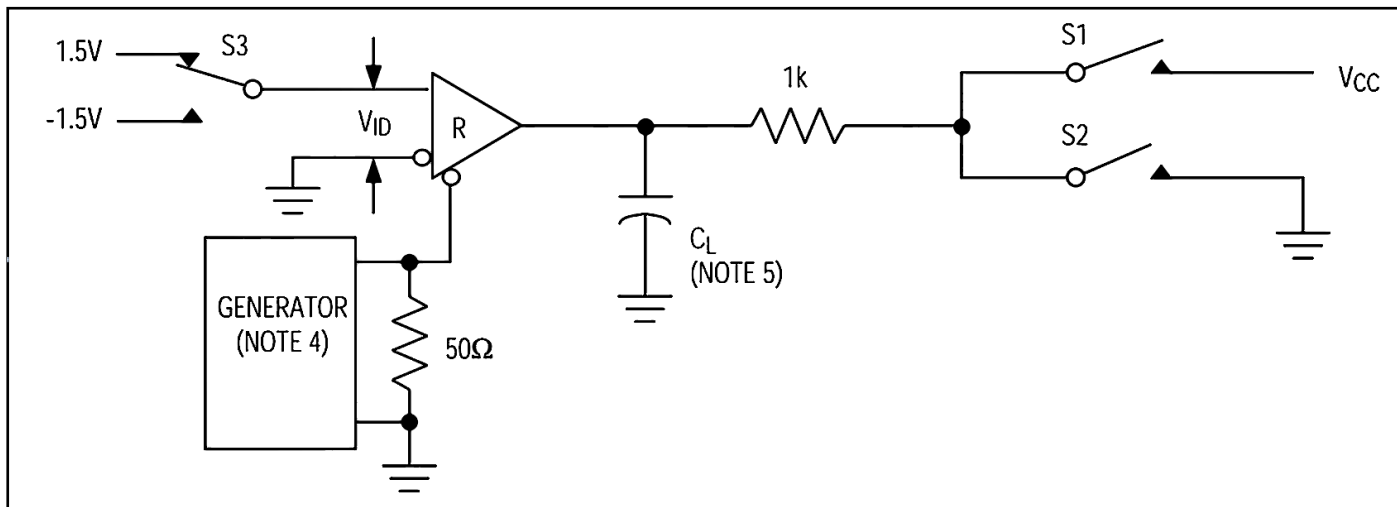

Figure 7: Receiver Propagation Delay Test Circuit



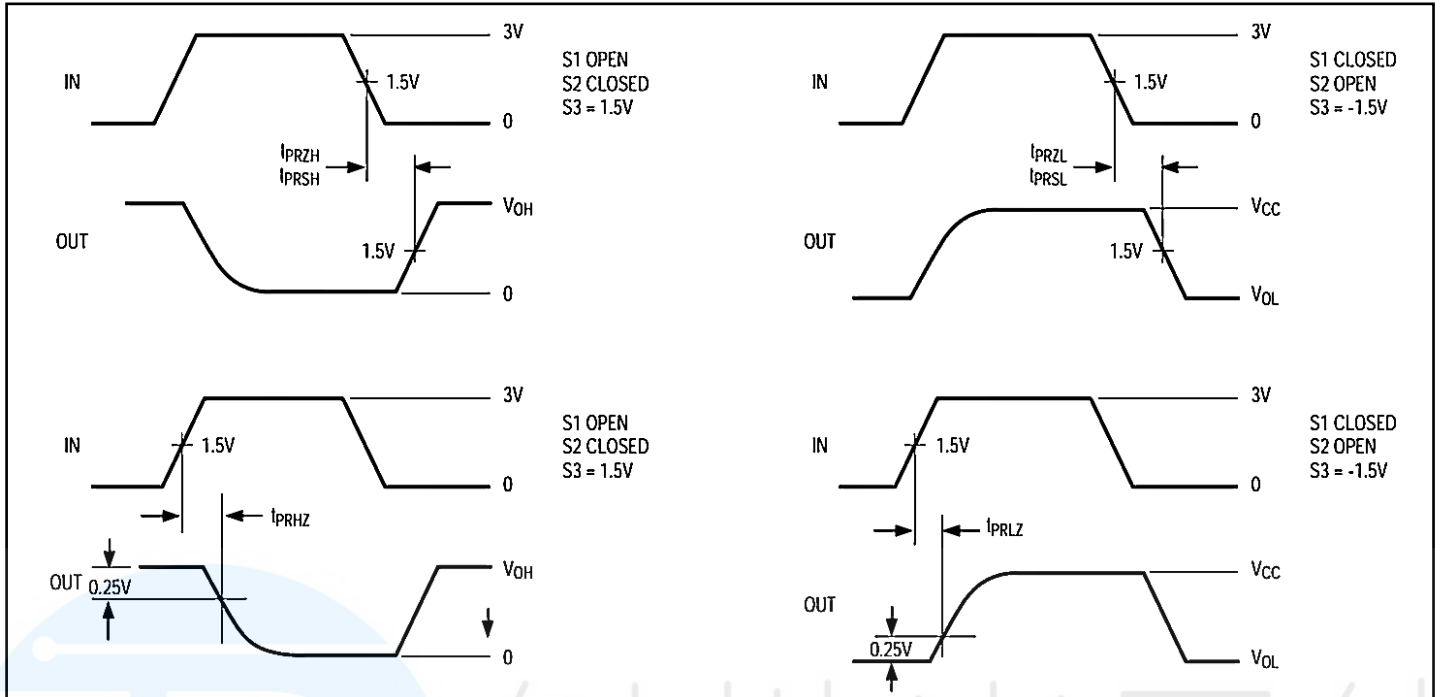

Figure 8 Receive enable and disable time

## Order information

Order Number	Package	Package Quantity	Marking On The park	Temperature
SN75ALS180N-TUDI	DIP14	Tube,25,A box of 1000	SN75LBC180N	0°C to 70°C
SN75ALS180DR-TUDI	SOP14	Tape,Reel,2500	75LBC180A	
SN65ALS180N-TUDI	DIP14	Tube,25,A box of 1000	75LBC180	- 40°C to 85°C
SN65ALS180DR-TUDI	SOP14	Tape,Reel,2500	75LBC180A	



Package SOP14

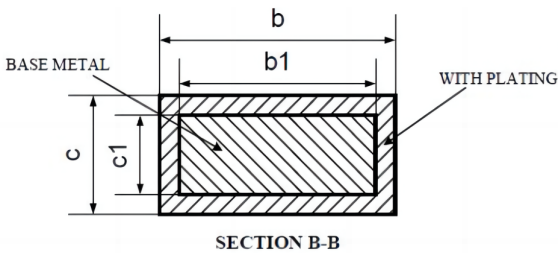
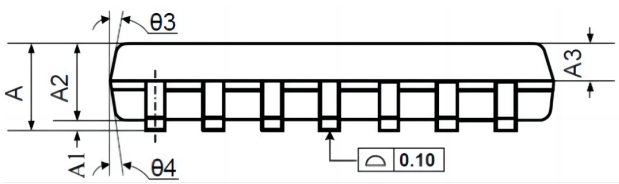
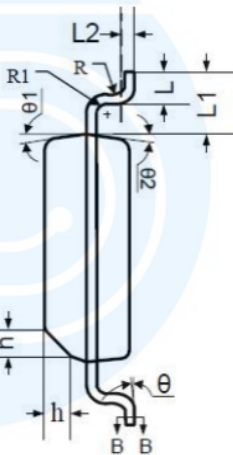
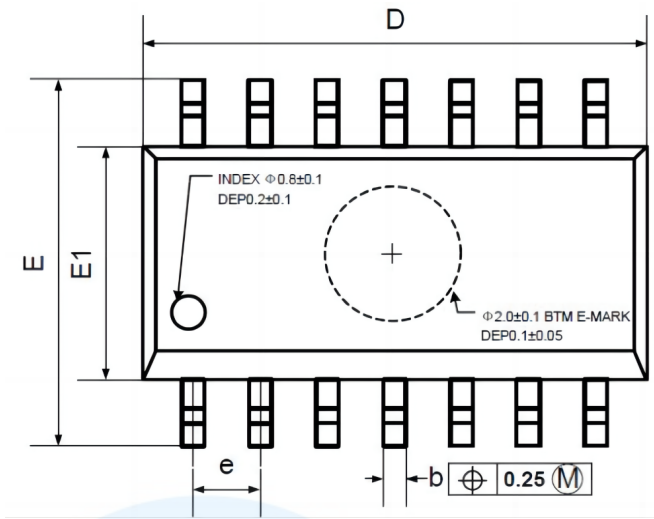

Symbol	Dimensions In Millimeters		
	MIN	NOM	MAX
A	1.35	1.60	1.75
A1	0.10	0.15	0.25
A2	1.25	1.45	1.65
A3	0.55	0.65	0.75
b	0.36		0.49
b1	0.35	0.40	0.45
C	0.16		0.25
c1	0.15	0.20	0.25
D	8.53	8.63	8.73
E	5.80	6.00	6.20
E1	3.80	3.90	4.00
e	1.27 BSC		
L	0.45	0.60	0.80
L1	1.04 REF		
L2	0.25 BSC		
R	0.07		
R1	0.07		
h	0.30	0.40	0.50
θ	0°		8°
θ1	6°	8°	10°
θ2	6°	8°	10°
θ3	5°	7°	9°
θ4	5°	7°	9°



Package DIP14

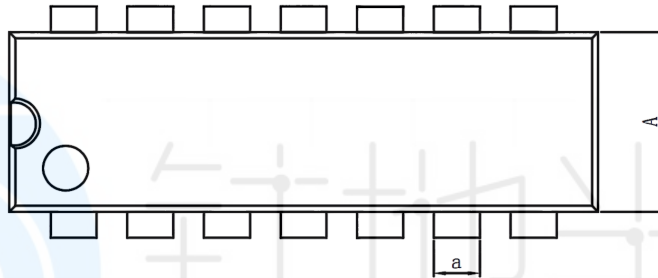
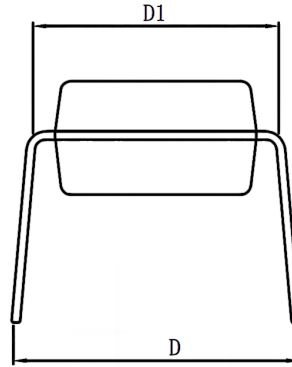
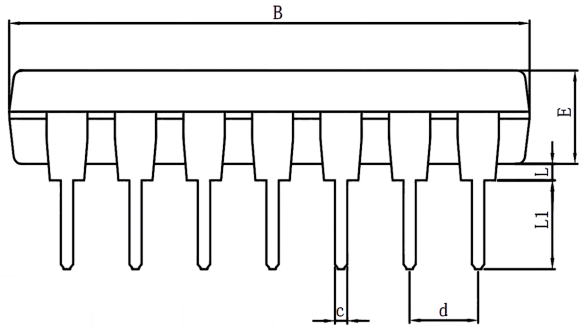

DIM.	MIN	TYP	MAX	DIM.	MIN	TYP	MAX
A	6.100	6.300	6.680	a	1.504	1.524	1.544
B	18.940	19.200	19.560	C	0.437	0.457	0.477
D	8.200	8.700	9.200	d	2.530	2.540	2.550
D1	7.42	7.62	7.82	L	0.500	—	0.800
E	3.100	3.300	3.550	L1	3.000	3.200	3.600



## Important statement:

- TUDI Semiconductor reserves the right to modify the product manual without prior notice! Before placing an order, customers need to confirm whether the obtained information is the latest version and verify the completeness of the relevant information.
- Any semi-guide product is subject to failure or malfunction under specified conditions. It is the buyer's responsibility to comply with safety standards when using TUDI Semiconductor products for system design and whole machine manufacturing. And take the appropriate safety measures to avoid the potential in the risk of loss of personal injury or loss of property situation!
- TUDI Semiconductor products have not been licensed for life support, military, and aerospace applications, and therefore TUDI Semiconductor is not responsible for any consequences arising from the use of this product in these areas.
- If any or all TUDI Semiconductor products (including technical data, services) described or contained in this document are subject to any applicable local export control laws and regulations, they may not be exported without an export license from the relevant authorities in accordance with such laws.
- The specifications of any and all TUDI Semiconductor products described or contained in this document specify the performance, characteristics, and functionality of said products in their standalone state, but do not guarantee the performance, characteristics, and functionality of said products installed in Customer's products or equipment. In order to verify symptoms and conditions that cannot be evaluated in a standalone device, the Customer should ultimately evaluate and test the device installed in the Customer's product device.
- TUDI Semiconductor documentation is only allowed to be copied without any alteration of the content and with the relevant authorization. TUDI Semiconductor assumes no responsibility or liability for altered documents.
- TUDI Semiconductor is committed to becoming the preferred semiconductor brand for customers, and TUDI Semiconductor will strive to provide customers with better performance and better quality products.