

Feature

Epitaxial planar die construction
Complementary PNP Type available(PZT2222A)

SOT-223

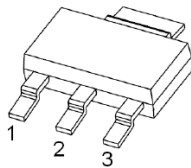

1. BASE
2. COLLECTOR
3. EMITTER

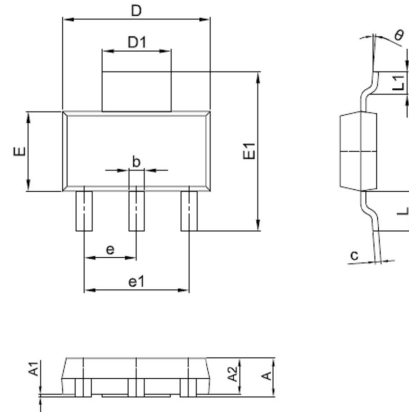

Symbol	Millimeter		Inches	
	Min.	Max.	Min.	Max.
A	1.50	1.80	0.059	0.071
A1	0.00	0.10	0.000	0.004
A2	1.50	1.70	0.059	0.067
b	0.65	0.75	0.026	0.030
c	0.20	0.30	0.008	0.012
D	6.40	6.60	0.252	0.260
D1	2.90	3.10	0.114	0.122
E	3.30	3.70	0.130	0.146
E1	6.85	7.15	0.270	0.281
e	2.20	2.40	0.087	0.094
e1	4.40	4.80	0.173	0.189
L	1.65	1.85	0.065	0.073
L1	0.90	1.15	0.035	0.045

MAXIMUM RATINGS (T_a=25°C unless otherwise noted)

Symbol	Parameter	Value	Unit
V _{CBO}	Collector-Base Voltage	-60	V
V _{CEO}	Collector-Emitter Voltage	-60	V
V _{EBO}	Emitter-Base Voltage	-5	V
I _C	Collector Current -Continuous	-0.6	A
P _C	Collector Power Dissipation	1	W
T _J	Junction Temperature	150	°C
T _{stg}	Storage Temperature	-55~+150	°C

PZT2907A

ELECTRICAL CHARACTERISTICS (T_a=25°C unless otherwise specified)

Parameter	Symbol	Test conditions	Min	Typ	Max	Unit
Collector-base breakdown voltage	V _{(BR)CBO}	I _C =-10μA, I _E =0	-60			V
Collector-emitter breakdown voltage	V _{(BR)CEO}	I _C =-10mA, I _B =0	-60			V
Emitter-base breakdown voltage	V _{(BR)EBO}	I _E =-10μA, I _C =0	-5			V
Collector cut-off current	I _{CBO}	V _{CB} =-50V, I _E =0			-10	nA
Emitter cut-off current	I _{EBO}	V _{EB} =-5V, I _C =0			-50	nA
DC current gain	h _{FE(1)}	V _{CE} =-10V, I _C =-0.1mA	75			
	h _{FE(2)}	V _{CE} =-10V, I _C =-1mA	100			
	h _{FE(3)}	V _{CE} =-10V, I _C =-10mA	100			
	h _{FE(4)}	V _{CE} =-10V, I _C =-150mA	100		300	
	h _{FE(5)}	V _{CE} =-10V, I _C =-500mA	50			
Collector-emitter saturation voltage	V _{CE(sat)}	I _C =-150mA, I _B =-15mA			-0.4	V
	V _{CE(sat)}	I _C =-500mA, I _B =-50mA			-1.6	V
Base-emitter saturation voltage	V _{BE(sat)}	I _C =-150mA, I _B =-15mA			-1.3	V
	V _{BE(sat)}	I _C =-500mA, I _B =-50mA			-2.6	V
Transition frequency	f _T	V _{CE} =-20V, I _C =-50mA, f=100MHz	200			MHz
Collector capacitance	C _c	V _{CB} =-10V, I _E =0, f=1MHz			8	pF
Emitter capacitance	C _E	V _{EB} =-2V, I _C =0, f=1MHz			30	pF
Delay time	t _d	I _C =-150mA I _{B1} =- I _{B2} =- 15mA			12	ns
Rise time	t _r				30	ns
Storage time	t _S				300	ns
Fall time	t _f				65	ns

RATING AND CHARACTERISTIC CURVES (PZT2907A)

