



BCZ120N80M1

N-Channel Silicon Carbide Power MOSFET

1200 V, 34 A, 80 mΩ

bestirpower

Features

- High switching speed with a low gate charge
- Fast intrinsic diode with low reverse recovery
- Robust Avalanche Capability
- 100% Avalanche Tested
- Pb-free, Halogen Free, and RoHS Compliant

$BV_{DSS, T_C=25^\circ C}$	$I_D, T_C=25^\circ C$	$R_{DS(on), typ}$	$Q_{g, typ}$
1200 V	34 A	80 mΩ	52 nC

Benefits

- System efficiency improvement
- Higher frequency applicability
- Increased power density
- Reduced cooling effort

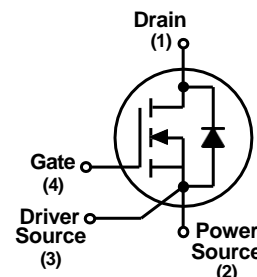

Applications

- Solar inverter
- EV charging station
- UPS
- Industrial power supply



Absolute Maximum Ratings ($T_J = 25^\circ C$ unless otherwise noted)

Symbol	Parameter	Value	Unit
V_{DSS}	Drain to Source Voltage	1200	V
V_{GS}	Gate to Source Voltage (DC)	-10 / +22	V
V_{GSop}	Recommended Operation Value	-5 / +18	V
I_D	Drain Current	$V_{GS} = 18 V, (T_C = 25^\circ C)$	34
		$V_{GS} = 18 V, (T_C = 100^\circ C)$	24
I_{DM}	Drain Current	Pulsed (Note1)	80
P_D	Power Dissipation	$(T_C = 25^\circ C)$	150
		Derate Above 25°C	1.00
T_J, T_{STG}	Operating and Storage Temperature Range	-55 to 175	°C
T_L	Maximum Lead Temperature for Soldering, 1/8" from Case for 10 Seconds	260	°C

※Note 1 : Limited by maximum junction temperature.

Thermal Characteristics

Symbol	Parameter	Value	Unit
$R_{\theta JC}$	Thermal Resistance, Junction to Case, Max.	1	°C/W
$R_{\theta JA}$	Thermal Resistance, Junction to Ambient, Max.	40	
T_{sold}	Soldering temperature, wave soldering only allowed at leads	260	°C

Electrical Characteristics (T_J = 25°C unless otherwise noted)

Symbol	Parameter	Test Conditions	Min	Typ	Max	Unit
--------	-----------	-----------------	-----	-----	-----	------

Off Characteristics

BV _{DSS}	Drain to Source Breakdown Voltage	V _{GS} = 0 V, I _D = 1 mA	1200	-	-	V
I _{DSS}	Zero Gate Voltage Drain Current	V _{DS} = 1200 V, V _{GS} = 0 V	-	1	100	μA
		V _{DS} = 1200 V, V _{GS} = 0 V, T _J = 175°C	-	5	-	
I _{GSS}	Gate-Source Leakage Current	V _{GS} = +22 V, V _{DS} = 0 V	-	-	+100	nA
		V _{GS} = -10 V, V _{DS} = 0 V	-	-	-100	

On Characteristics

V _{GS(th)}	Gate Threshold Voltage	V _{GS} = V _{DS} , I _D = 5.0 mA (tested after V _{GS} = 22 V, 1 ms pulse)	2.0	3.0	4.5	V
R _{DS(on)}	Static Drain to Source On Resistance	V _{GS} = 18 V, I _D = 15 A	-	80	110	mΩ
		V _{GS} = 18 V, I _D = 15 A, T _J = 175°C	-	128	-	
g _{fs}	Transconductance	V _{DS} = 20 V, I _D = 15 A	-	11.4	-	S

Dynamic Characteristics

C _{iss}	Input Capacitance	V _{DS} = 800 V, V _{GS} = 0V, f = 250 kHz	-	880	-	pF
C _{oss}	Output Capacitance		-	64	-	
C _{riss}	Reverse Capacitance		-	5	-	
E _{oss}	Stored Energy in Output Capacitance	V _{DS} = 0 V to 800 V, V _{GS} = 0 V	-	26	-	μJ
C _{o(er)}	Energy Related Output Capacitance		-	80	-	pF
C _{o(tr)}	Time Related Output Capacitance		-	142	-	
Q _{g(tot)}	Total Gate Charge	V _{DS} = 800 V, I _D = 15 A, V _{GS} = -5 V / 18 V, Inductive load	-	52	-	nC
Q _{gs}	Gate to Source Charge		-	13	-	
Q _{gd}	Gate to Drain "Miller" Charge		-	17	-	
R _G	Internal Gate Resistance	f = 1 MHz open drain	-	4.0	-	Ω

Switching Characteristics

t _{d(on)}	Turn-On Delay Time	V _{DS} = 800 V, I _D = 15 A, V _{GS} = -5 V / 18 V, R _G = 2 Ω, FWD : BCH120S010D1, Inductive load	-	14	-	ns
t _r	Turn-On Rise Time		-	9	-	
t _{d(off)}	Turn-Off Delay Time		-	24	-	
t _f	Turn-Off Fall Time		-	8	-	μJ
E _{on}	Turn-on Switching Energy		-	75	-	
E _{off}	Turn-off Switching Energy		-	47	-	
E _{tot}	Total Switching Energy		-	122	-	

Source-Drain Diode Characteristics

I _S	Maximum Continuous Diode Forward Current	V _{GS} = -5 V, I _{SD} = 15 A	-	-	30	A
I _{SM}	Maximum Pulsed Diode Forward Current		-	-	80	
V _{SD}	Diode Forward Voltage	V _{GS} = -5 V, I _{SD} = 15 A	-	4.1	-	V
t _{rr}	Reverse Recovery Time	V _{DD} = 800 V, I _{SD} = 15 A, di _F /dt = 3000 A/μs, Includes Q _{oss}	-	12	-	ns
Q _{rr}	Reverse Recovery Charge		-	122	-	nC

Typical Performance Characteristics

Figure 1. On-Region Characteristics $T_J = -40^\circ\text{C}$

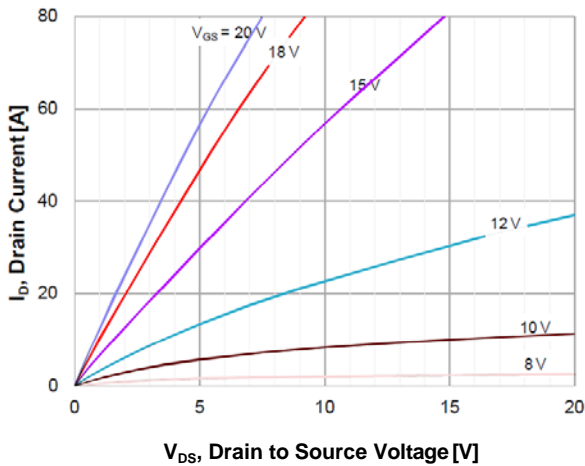

Figure 2. On-Region Characteristics $T_J = 25^\circ\text{C}$

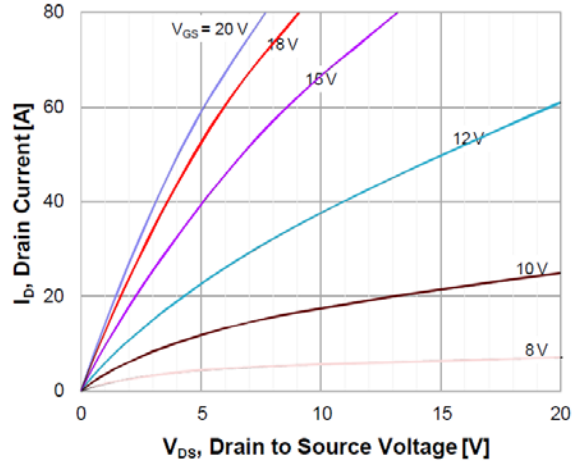

Figure 3. On-Region Characteristics $T_J = 175^\circ\text{C}$

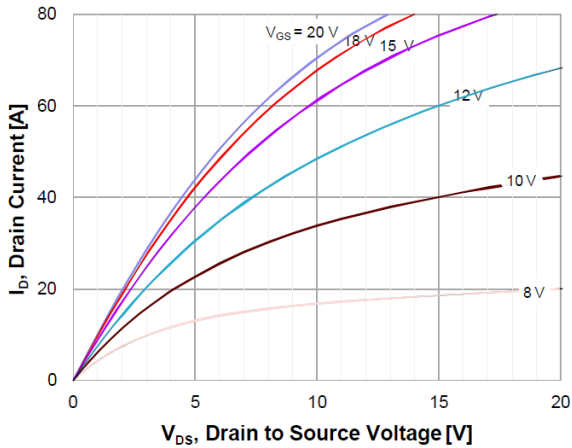

Figure 4. Normalized On-Resistance Characteristics vs. Temperature

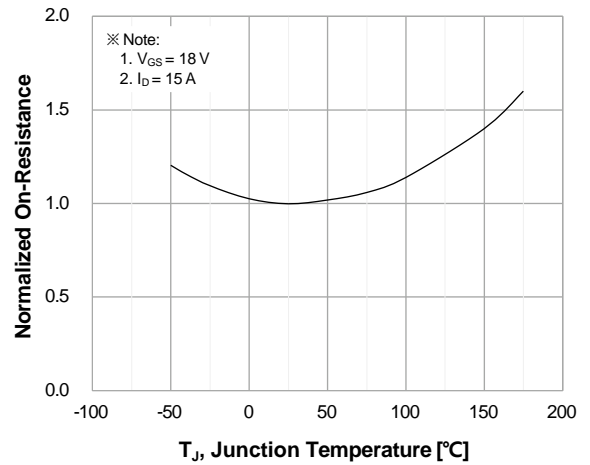

Figure 5. Transfer Characteristics

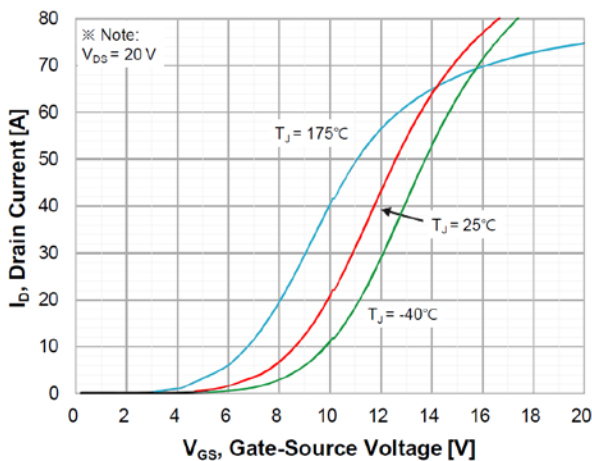
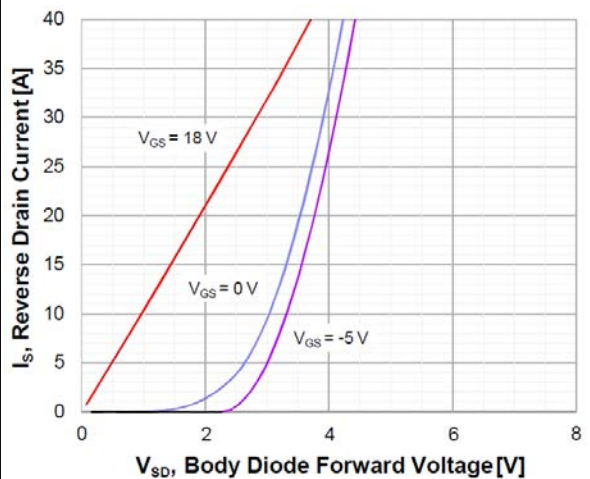

Figure 6. Diode Forward Voltage Characteristics vs. Source-Drain Current $T_J = -40^\circ\text{C}$



Typical Performance Characteristics

Figure 7. Diode Forward Voltage Characteristics vs. Source-Drain Current $T_J = 25^\circ\text{C}$

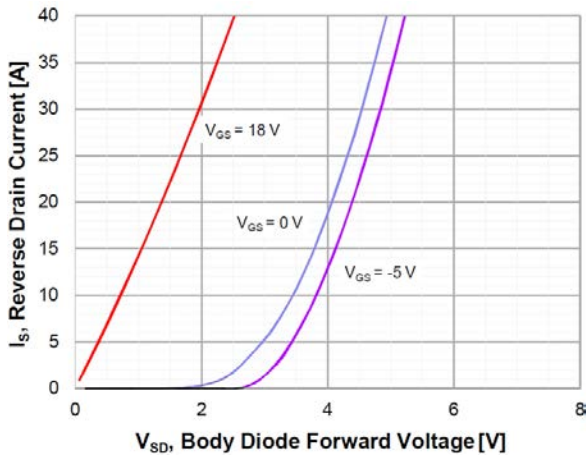

Figure 8. Diode Forward Voltage Characteristics vs. Source-Drain Current $T_J = 175^\circ\text{C}$

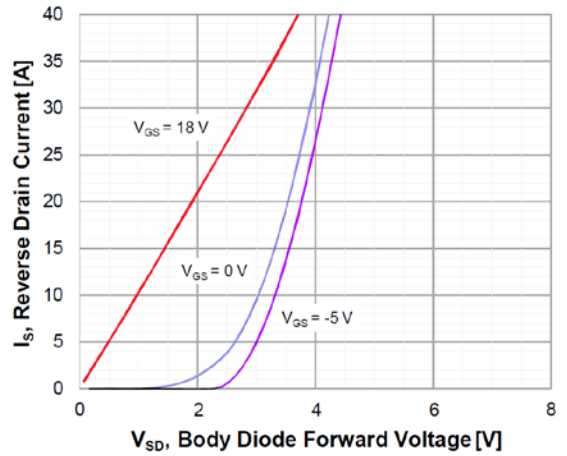

Figure 9. Threshold Voltage vs. Temperature

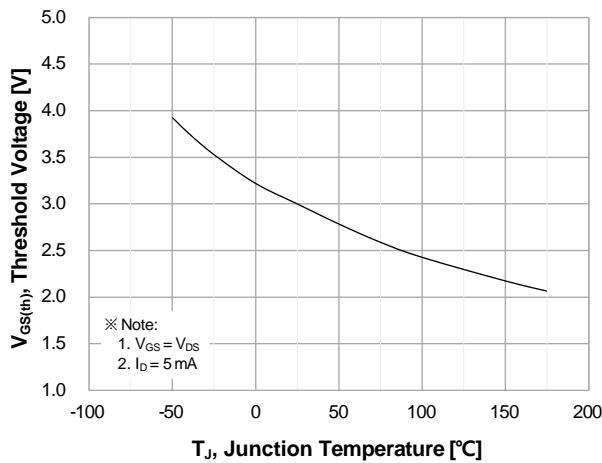

Figure 10. Gate Charge Characteristics

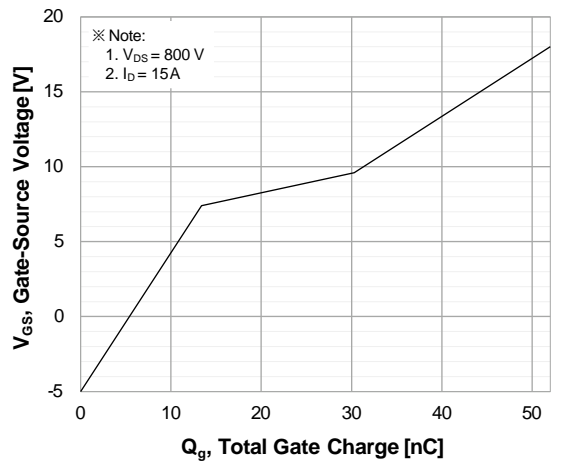

Figure 11. Stored Energy in Output Capacitance

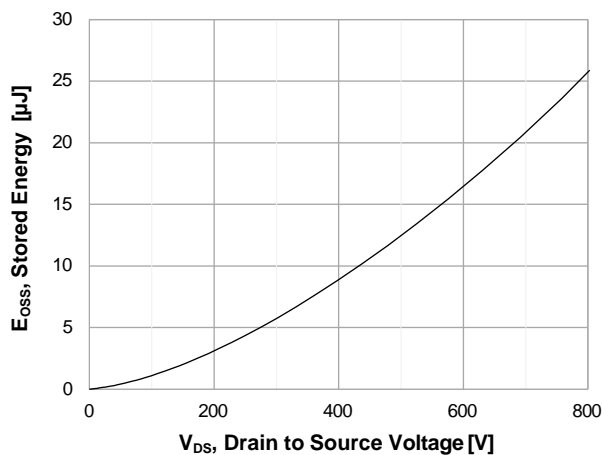
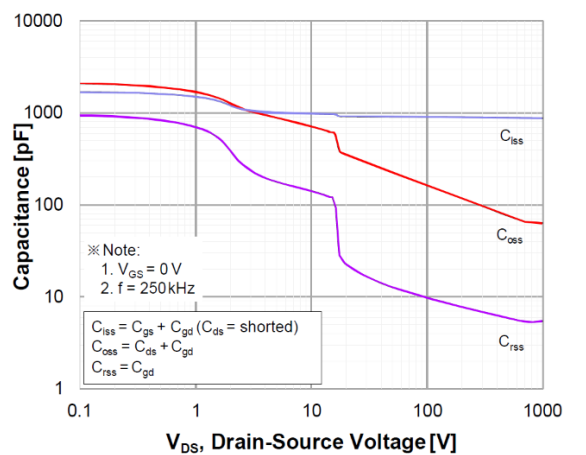

Figure 12. Capacitance Characteristics



Typical Performance Characteristics

Figure 13. Continuous Drain Current Derating vs. Case Temperature

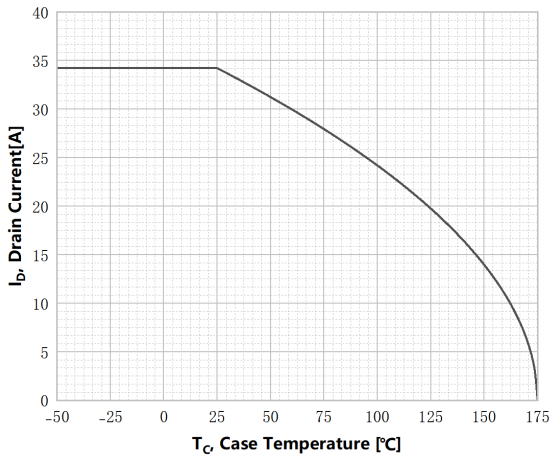

Figure 14. Maximum Power Dissipation Derating vs. Case Temperature

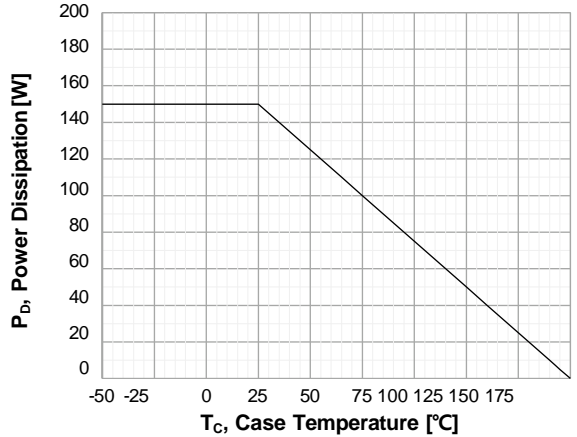

Figure 15. Typ. Switching Losses vs. Drain Current

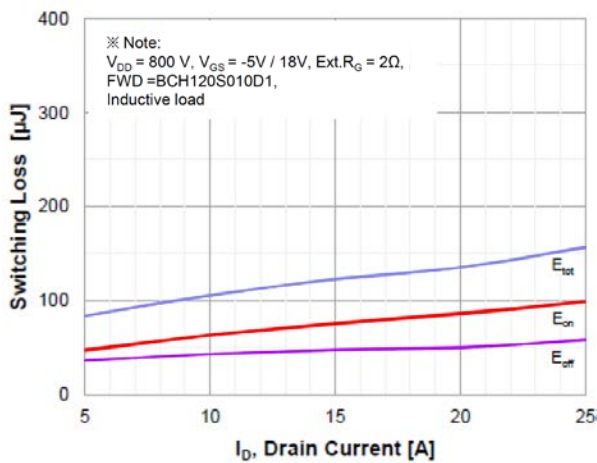

Figure 16. Typ. Switching Losses vs. Gate Resistance

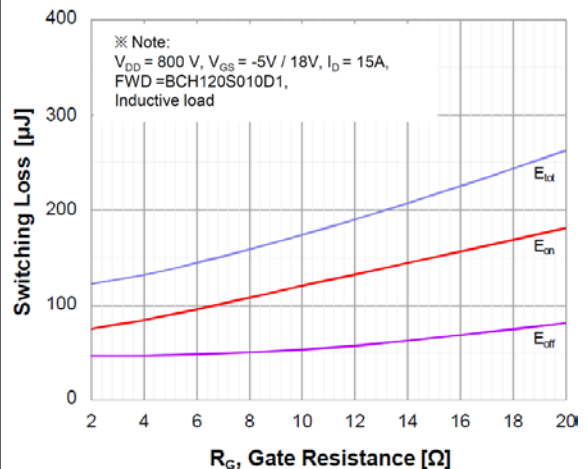

Figure 17. Typ. Switching Losses vs. Drain Current

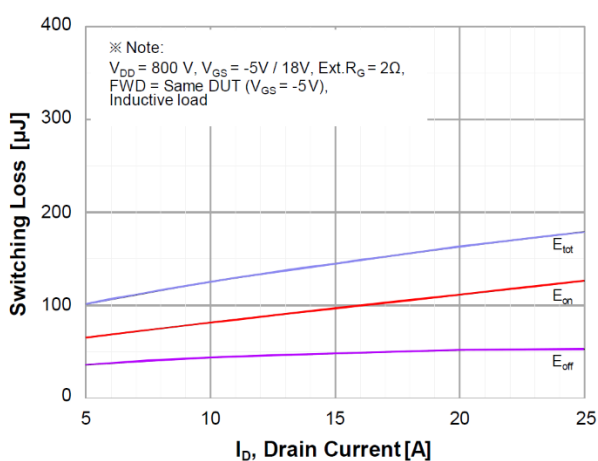
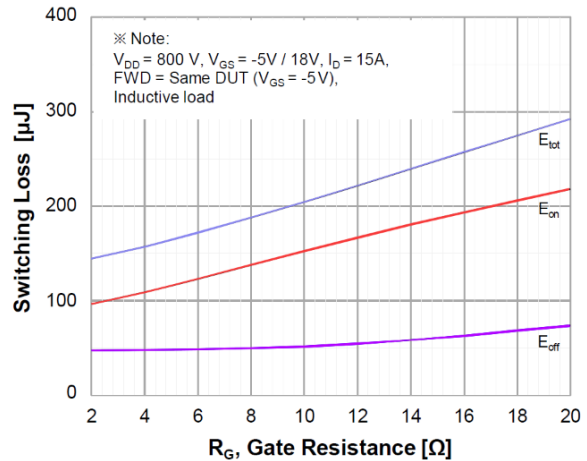

Figure 18. Typ. Switching Losses vs. Gate Resistance



Typical Performance Characteristics

Figure 19. Maximum Safe Operating Area

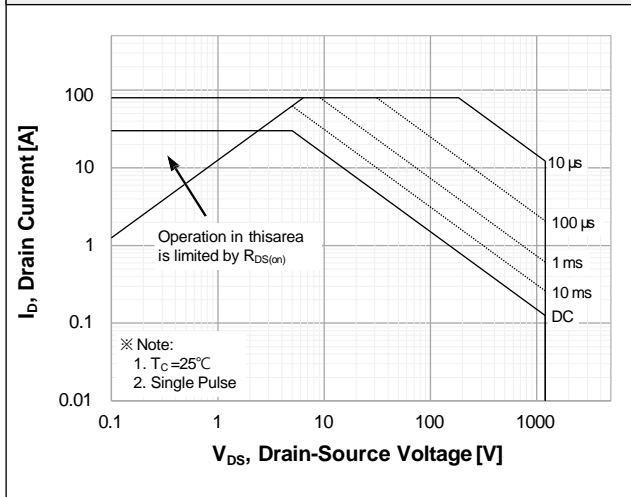

Figure 20. Transient Thermal Response Curve

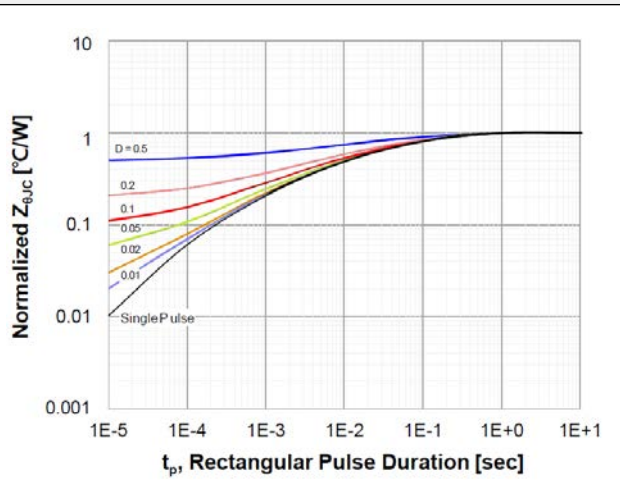

Figure 21. Inductive Load Switching Test Circuit and Waveforms

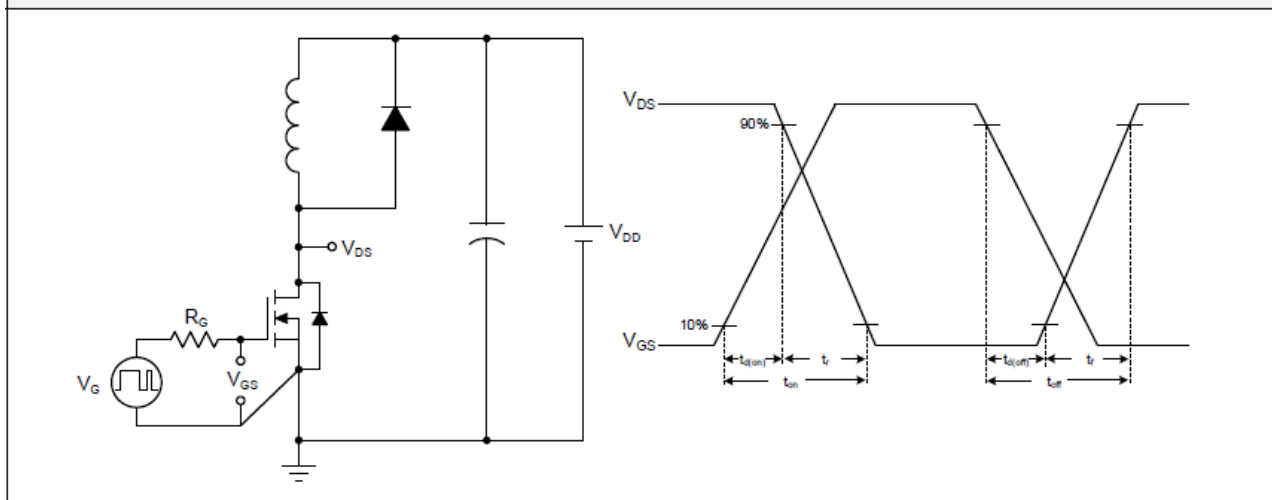
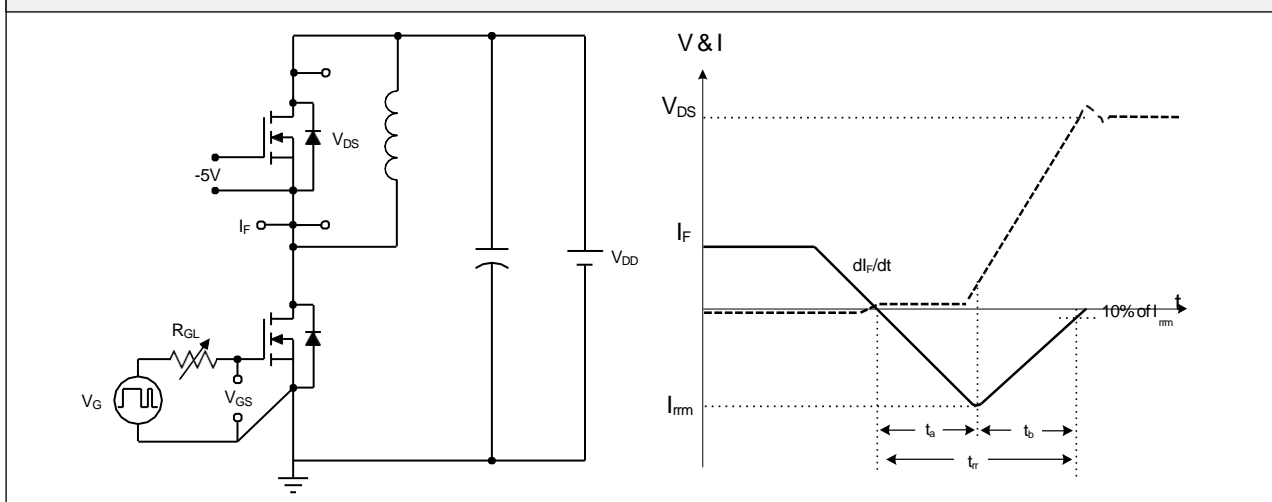
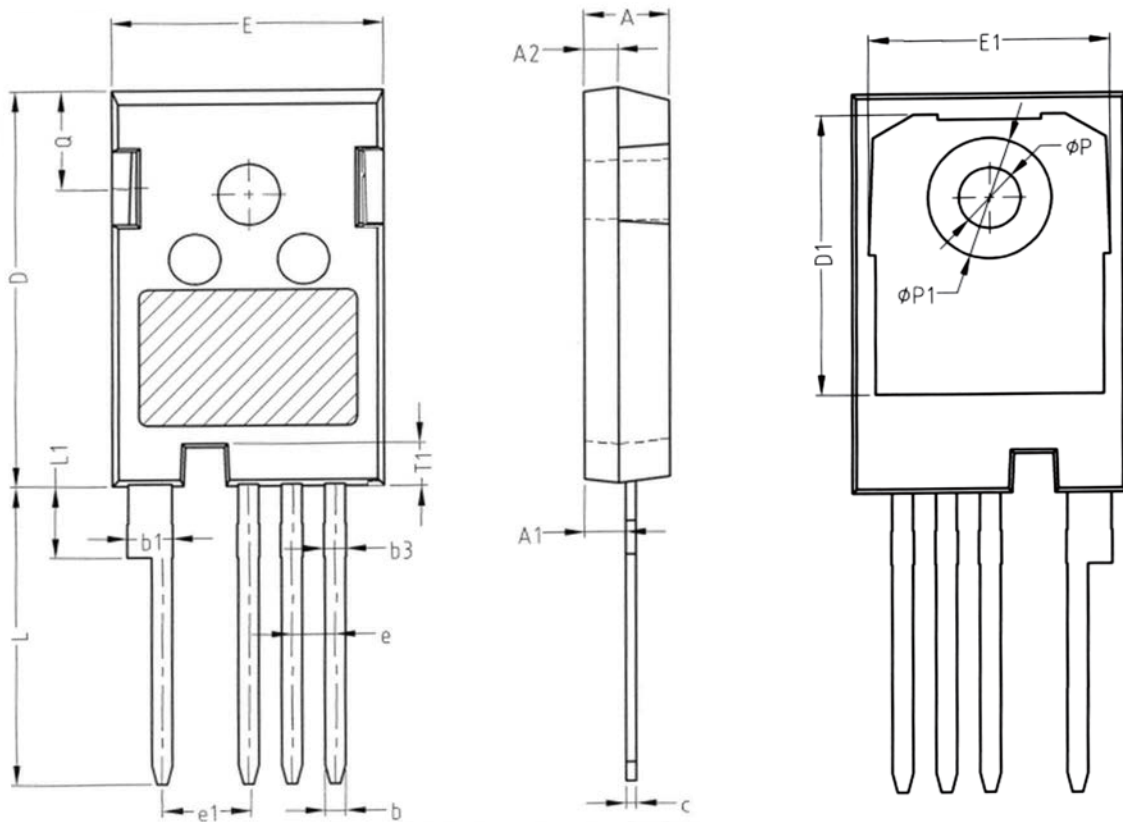

Figure 22. Peak Diode Recovery dv/dt Test Circuit and Waveforms



Package Outlines

TO247-4



SYMBOL	NM		
	MIN	NOM	MAX
A	4.80	5.00	5.20
A1	2.21	2.41	2.61
A2	1.80	2.00	2.20
b	1.06	1.21	1.36
b1	2.33	2.63	2.93
b3	1.07	1.30	1.60
c	0.51	0.61	0.75
D	23.30	23.45	23.60
D1	16.25	16.55	16.85
E	15.74	15.94	16.14
E1	13.72	14.02	14.32
T1	2.35	2.50	2.65
e	2.54 BSC		
e1	5.08 BSC		
Q	5.49	5.79	6.09
L	17.27	17.57	17.87
L1	3.99	4.19	4.39
ϕp	3.40	3.60	3.80
$\phi p1$	7.19 REF		

* Dimensions in millimeters

Package Marking and Ordering Information

Part Number	Top Marking	Package	Packing Method	Quantity
BCZ120N80M1	BCZ120N80M1	TO247-4L	Tube	30 units

Disclaimer

Bestirpower reserve the right to make changes, corrections, enhancements, modifications, and improvements to Bestirpower products and/or to this document at any time without notice.

The information given in this document shall in no event be regarded as a guarantee of conditions or characteristics. Bestirpower does not assume any liability for infringement of patents, copyrights, or other intellectual property rights of third parties by or arising from the use of Products or technical information described in this document.

This document is the property of Bestirpower Co., LTD., and not allowed to copy or transformed to other format if not under the authority approval.

© 2023 Bestirpower – All rights reserved