

Product packaging logic diagram

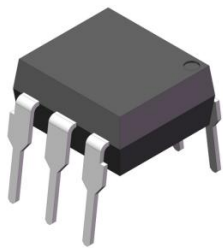

DIP6

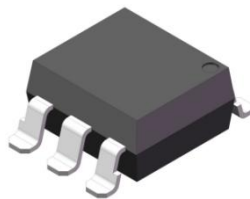

SMD6

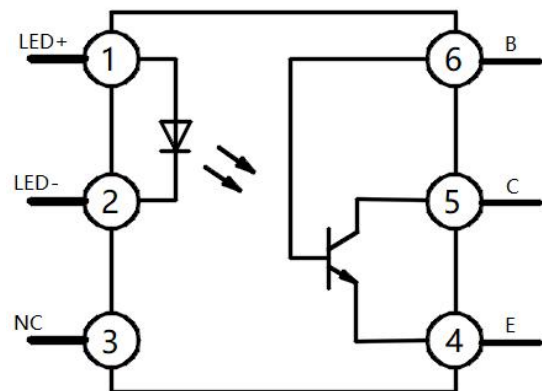

Pin Configuration

Features

- Current transfer ratio
(CTR: $\geq 100\%$ at $I_F = 10\text{mA}$, $V_{CE} = 10\text{V}$)
- High isolation voltage between input and output ($V_{iso} = 5000\text{Vrms}$)
- Operating Temperature: $-55^\circ\text{C} \sim 100^\circ\text{C}$
- Environmentally friendly products, compliant with CQC, UL, and VDE requirements

Mechanical Data

- Case: DIP6, SMD6
- Molding Compound: UL Flammability Classification Rating 94V-0
- Terminals: Matte tin-plated leads; solder ability-per MIL-STD-202, Method 208

Applications

- Industrial automation equipment (PLC module, sensor interface)
- Measurement instrument signal isolation
- Design and application of smart meters and switching power supplies
- Photo voltaic inverters, energy storage system applications
- Main control circuit for household appliances (air conditioning, refrigerator, water heater);



Ordering Information

<u>XL</u>	<u>CNY17-3</u>	<u>(M)</u>	<u>(G)</u>	-	<u>(U)</u>	<u>(N)</u>	<u>(Y)</u>
①	②	③	④		⑤	⑥	⑦

- ① Brand(XL)
- ② Product series(CNY17-3)
- ③ Package type(DIP6L:None, SMD6:S)
- ④ Halogen option(None :Halogen free)
- ⑤ Lead frame (None: Copper)
- ⑥ Customer option 1 (0-9 or A-Z or none)
- ⑦ Customer option 2 (0-9 or A-Z or none)

Part Number	Package	Shipping Quantity	Marking Code
XLCNY17-3	DIP6	65pcs / Tube	XLCNY17-3
XLCNY17-3S	SMD6	1000pcs / Tape & Reel	XLCNY17-3

Marking Information

- " XL" denotes brand.
- " CNY17-3" denotes Product series.
- " Y" denotes Year : A(2024), B(2025), C(2026)
- " WW" denotes Week' s number .
- " N" denotes the day of Week.

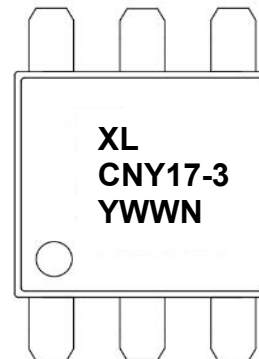

Maximum Ratings (@ T_A = 25°C unless otherwise specified)

Parameter		Symbol	Value	Unit
Input	Forward Current	I _F	60	mA
	Forward Peak Current*1	I _{FP}	1	A
	Reverse Voltage	V _R	6	V
	Power Dissipation	P _D	100	mW
Output	Collector Power Dissipatio	P _C	300	mW
	Collected Current	I _C	100	mA
	Collector-Base Voltage	V _{CB0}	70	V
	Collector-Emitter Voltage	V _{CEO}	30	V
	Eemitter- Collector Voltage	V _{ECO}	7	V

Thermal Characteristics

Parameter	Symbol	Value	Unit
Total Power Dissipation	P _{TOT}	350	mW
Isolation Voltage *2	V _{ISO}	5000	V _{rms}
Operating Temperature	T _{OPR}	-55 ~ +100	°C
Storage Temperature Range	T _{STG}	-55 ~ +125	°C
Soldering Temperature *3	T _{SOL}	260	°C

Notes:

1. Pulse width ≤ 1μs, Duty ratio: 0.001
2. 40 to 60% RH, AC for 1 minute. At this time, pins 1, 2 & 3 are shorted, and pins 4, 5 & 6 are shorted together.
3. For 10 seconds

Electrical Characteristics (@ T_A = 25°C unless otherwise specified)

Parameter		Symbol	Test Condition	Min.	Typ.	Max.	Unit
Input	Forward Voltage	V _F	I _F = 10mA	-	1.2	1.5	V
	Reverse Current	I _R	V _R = 3V	-	-	10	μA
	Input Capacitance	C _t	V = 0V, f = 1kHz	-	50	-	pF
Output	Collector Dark Current	I _{CEO}	V _{CE} = 10V	-	-	50	nA
	Collector-Base Breakdown Voltage	B _V C _B O	I _B = 0.1mA, I _F = 0	70	-	-	V
	Collector-Emitter Breakdown Voltage	B _V C _E O	I _C = 0.1mA, I _F = 0	30	-	-	V
	Emitter-Collector Breakdown Voltage	B _V E _C O	I _E = 0.01mA, I _F = 0	7	-	-	V
Transfer Characteristics	Current Transfer Ratio	CTR	I _F = 10mA, V _{CE} = 10V	100	-	-	%
	Collector-Emitter Saturation Voltage	V _{CE(sat)}	I _F = 50mA, I _C = 2mA	-	-	0.3	V
	Isolation Resistance	R _{ISO}	DC500V, 40~60%R.H.	5*10 ¹⁰	10 ¹¹	-	Ω
	Isolation Capacitance	C _f	V = 0, f = 1MHz	-	1	2.5	pF
	Response Time (Rise)	T _r	V _{CE} = 10V	-	3	10	μs
	Response Time (Fall)	T _f	I _C = 2mA, R _L = 100Ω	-	3	10	μs

Ratings and Characteristics Curves (@ $T_A = 25^\circ\text{C}$ unless otherwise specified)

Fig.1 Forward Current vs. Forward Voltage

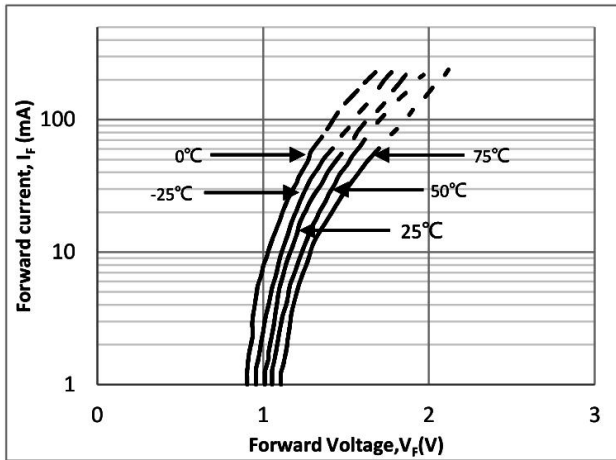

Fig.2 Collector Current vs. Collector-emitter Voltage

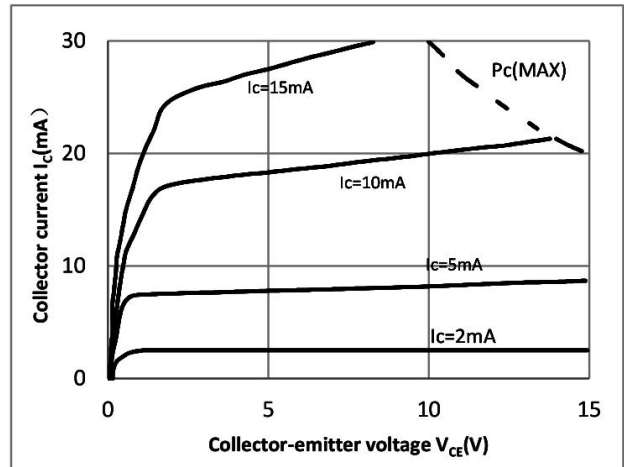

Fig.3 Forward Current vs. Forward Voltage

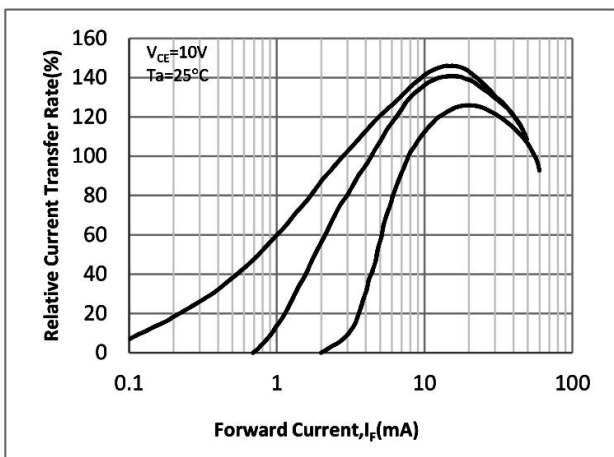

Fig.4 Collector-emitter Saturation Voltage vs. Forward Current

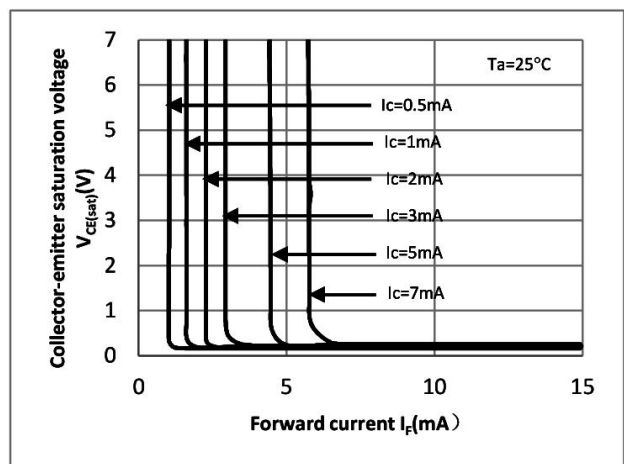

Fig.5 Collector Dark Current vs. Ambient Temperature

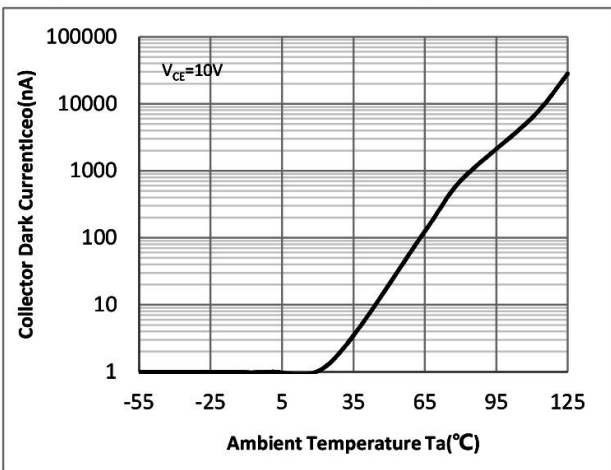
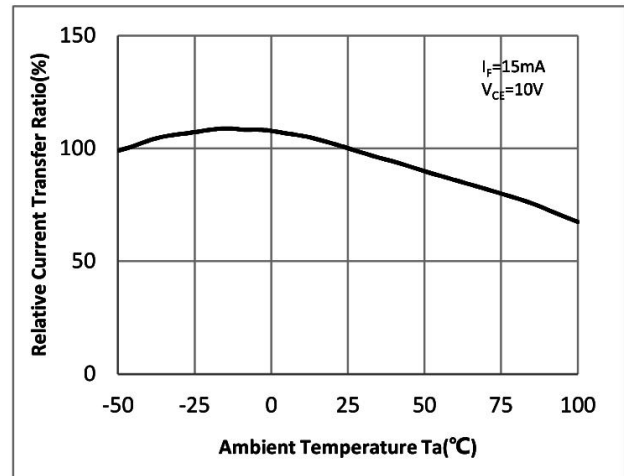

Fig.6 Relative Current Transfer Ratio vs. Ambient Temperature



Ratings and Characteristics Curves (@ T_A = 25°C unless otherwise specified)

Fig.7 Response Time vs. Load Resistance

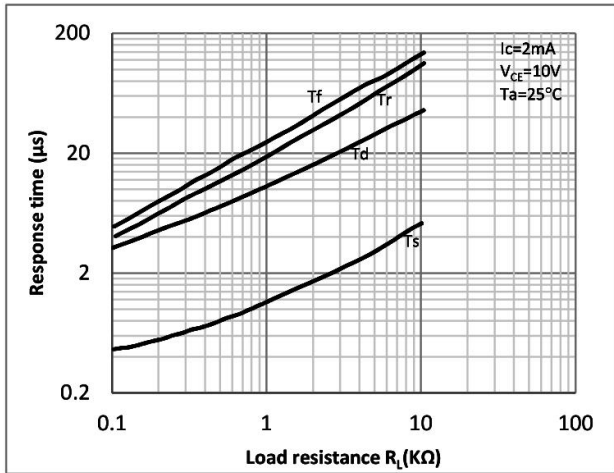
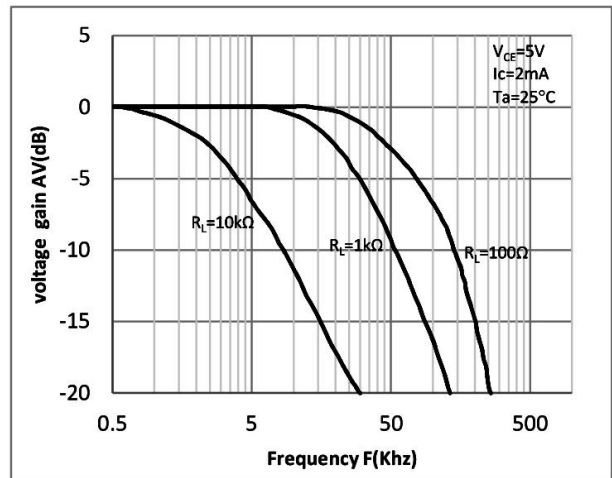
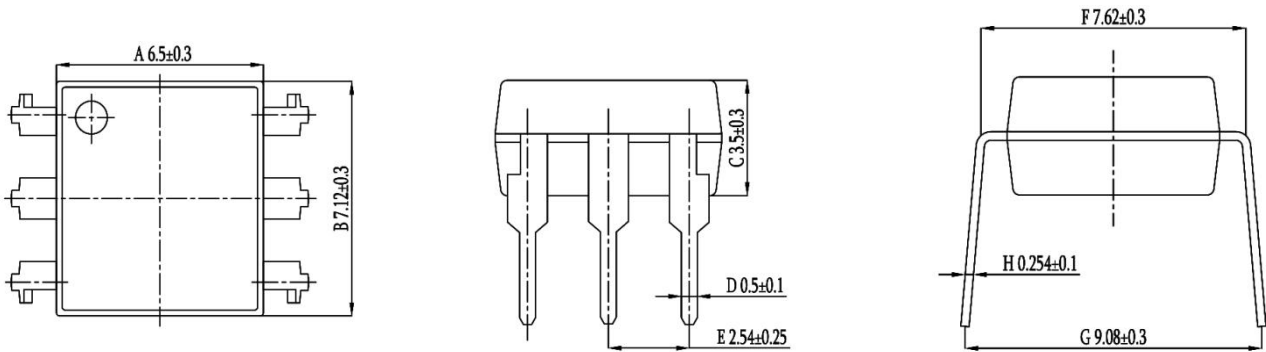

Fig.8 Frequency Response



**Package Outline Dimensions (unit: mm)
DIP6**



SMD6

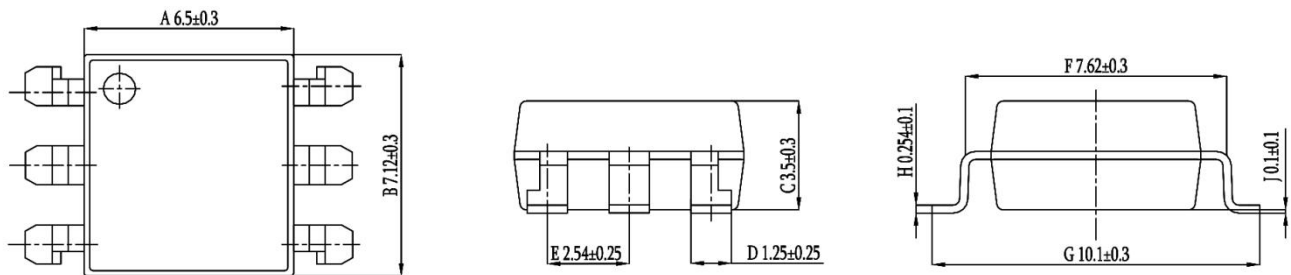

SOLDERING FOOTPRINT (unit: mm)

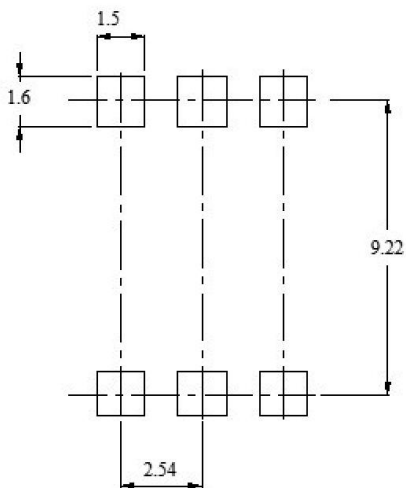

Reflow soldering

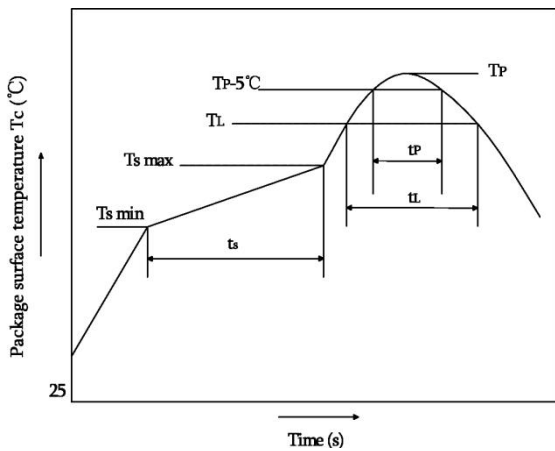

	Symbol	Min	Max	Unit
Preheat temperature	Ts	150	200	°C
Preheat time	ts	60	120	s
Ramp-up rate(T _L to T _P)	-	-	3	°C/s
Liquidus temperature	T _L	217		°C
Time above T _L	t _L	60	150	s
Peak temperature	T _P		260	°C
Time during which T _c is between (T _P -5) and T _P	t _p	-	30	s
Ramp-down rate(T _P to T _L)	-	-	6	°C/s

Note:

Reflow soldering is recommended at the temperatures and times shown, no more than three times.

Wave soldering

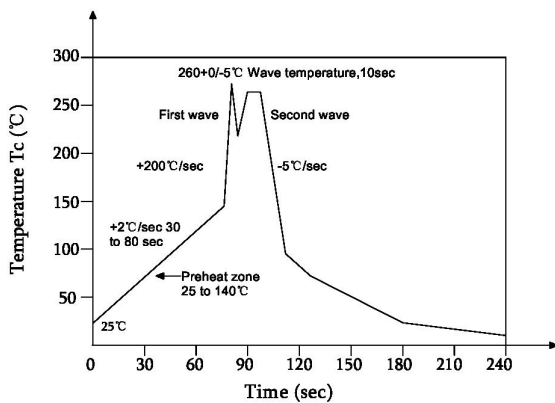

Profile feature	
Average ramp-up rate	~200°C/s
Heating rate during preheat	1°C/s to 2°C/s typical; 4°C/s maximum
Final preheat temperature T _s	~130°C
Preheat time (25°C to T _s)	> 60s
Peak temperature T _p	260°C
Time within peak temperature t _p	10s
Ramp-down rate	5°C/s maximum

Soldering with hand soldering iron

- A. Hand soldering iron is only used for product rework or sample testing.
- B. Hand soldering iron requirements: Temperature: 360 °C±5°C within 3s.

Packing

Package Type	Packing Form	Quantity per Tube & Reel	Quantity per Box	Quantity per Carton	Antistatic Bag Specification	Box Specification	Carton Specification	Note
DIP6	Tube(500mm)	65pcs/tube	25 tubes /box	12 boxes /ctn	190*670mm	520*105*50mm	545*372*235mm	Straight insert type material tube
SMD6	Reel(φ330mm)	1000pcs/reel	2 reels/box	5 boxes /ctn	380*420mm	350*340*60mm	365*330*370mm	Guard band 200mm/min.

■ **Summary table**

■ **DIP6 (Tube)**

Qty/ tube : 65pcs. Qty/box: 1625pcs.

Qty/ctn : 19500pcs.

Schematic: (unit:mm)

■ **SMD6 (Reel)**

Qty/reel: 1000pcs. Qty/box: 2000pcs.

Qty/ctn : 10000pcs.

Schematic: (unit:mm)

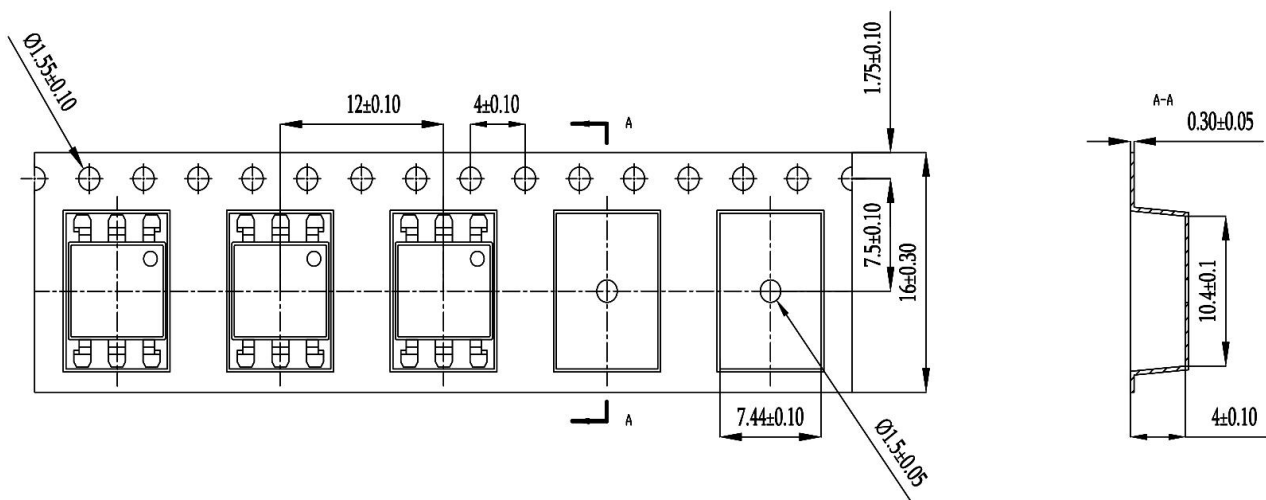

IMPORTANT NOTICE

XINGLIGHT reserves the right to make changes without further notice to any product herein to make corrections, modifications, improvements, or other changes. XINGLIGHT does not assume any liability arising out of the application or use of any product described herein; neither does it convey any license under its patent rights, nor the rights of others.