

SOREDE

索 瑞 达 电 子

深圳市索瑞达电子有限公司

承 认 书

SPECIFICATION FOR APPROVAL

客户名称: 标准通用
Customer Name : _____

客户料号:
Customer P/N: _____

产品名称: 插件电感
Product Name: _____

索瑞达料号: SH0810系列
Sorede P/N: _____

制造厂商 Manufacturer	
拟制 Draft	唐杨英
审核 Check	工程专用 符妃团
日期 Date	2021-10-22

客户承认印章 Approval Signet	
日期 Date	

地址: 深圳市观澜镇福城街道新塘村8号源创园陆号A6栋3楼.

Address: 3Rd Floor, Building A6, Yuanchuangyuanlu, No. 8 Xintang Village, Fucheng Street, Guanlan Town, Shenzhen.

电话 Tel: 0755-29803356 传真 Fax: 0755-29803506

电子邮件 E-mail: sorde@vip.163.com

网址 [http:// www.szsorede.com](http://www.szsorede.com)

1、外形尺寸 Dimension (单位Unit: mm) :

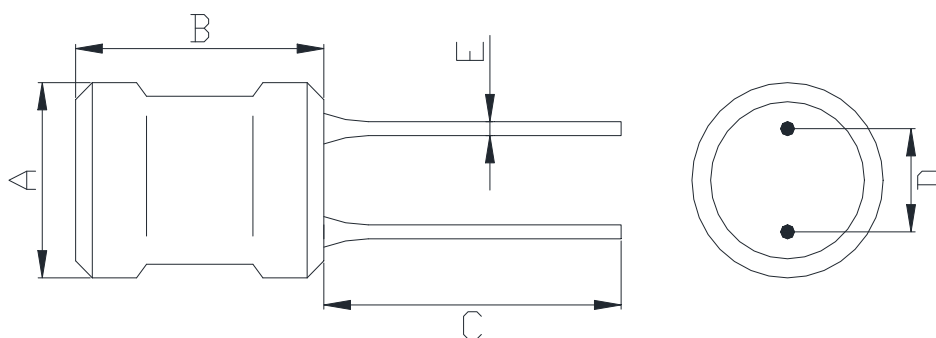

A	B	C	D	E
10.0 Max.	13 Max.	15.0 Ref	5.0±0.5	0.65

2、产品品名构成 Product Spec. Model

SH 0810 2R2 K T 00

a b c d e f

a: 系列名称 Series name

b: 产品尺寸 Product dimensions (A x B)

c: 电感值 Inductance Value

(1R0:1.0uH; 100: 10uH; 101:100uH)

d: 电感公差 Inductance Tolerance (J:5%; K:10% ; M:20%)

e: 包装 Package (T:磁带/卷轴 Tape/Reel、B: 散装 Bulk)

f: 编号 Numbering (标准 standard)

文件编号 File Number	SRD-WI-14783	版本号 Version Number	A	页码 page	2/6
---------------------	--------------	-----------------------	---	------------	-----

3、电性能参数表 Electrical Characteristics List

规格型号 Part NO.	电感量 Tolerance (uH)	测试频率 Test Freq. (kHz/v)	直流电阻 DCR Max (Ω)	饱和电流 Isat (A)
SH.0810.3R3MT00	3.3	1.0/0.25	0.012	5.00
SH.0810.3R9MT00	3.9	1.0/0.25	0.014	4.60
SH.0810.4R7MT00	4.7	1.0/0.25	0.016	4.30
SH.0810.5R6MT00	5.6	1.0/0.25	0.020	3.90
SH.0810.6R8MT00	6.8	1.0/0.25	0.022	3.70
SH.0810.8R2MT00	8.2	1.0/0.25	0.024	3.50
SH.0810.100KT00	10	1.0/0.25	0.025	3.20
SH.0810.120KT00	12	1.0/0.25	0.027	3.00
SH.0810.150KT00	15	1.0/0.25	0.033	2.80
SH.0810.180KT00	18	1.0/0.25	0.039	2.60
SH.0810.220KT00	22	1.0/0.25	0.047	2.40
SH.0810.270KT00	27	1.0/0.25	0.052	2.10
SH.0810.330KT00	33	1.0/0.25	0.075	1.90
SH.0810.390KT00	39	1.0/0.25	0.082	1.70
SH.0810.470KT00	47	1.0/0.25	0.100	1.50
SH.0810.560KT00	56	1.0/0.25	0.150	1.30
SH.0810.680KT00	68	1.0/0.25	0.180	1.20
SH.0810.820KT00	82	1.0/0.25	0.200	1.10
SH.0810.101KT00	100	1.0/0.25	0.210	0.90
SH.0810.121KT00	120	1.0/0.25	0.220	0.80
SH.0810.151KT00	150	1.0/0.25	0.240	0.72
SH.0810.181KT00	180	1.0/0.25	0.280	0.65
SH.0810.221KT00	220	1.0/0.25	0.350	0.60
SH.0810.271KT00	270	1.0/0.25	0.400	0.55
SH.0810.331KT00	330	1.0/0.25	0.470	0.50
SH.0810.391KT00	390	1.0/0.25	0.680	0.46
SH.0810.471KT00	470	1.0/0.25	0.800	0.42
SH.0810.561KT00	560	1.0/0.25	1.000	0.38
SH.0810.681KT00	680	1.0/0.25	1.200	0.35
SH.0810.821KT00	820	1.0/0.25	1.500	0.31
SH.0810.102KT00	1000	1.0/0.25	1.800	0.28
SH.0810.122KT00	1200	1.0/0.25	2.000	0.25
SH.0810.152KT00	1500	1.0/0.25	2.400	0.23
SH.0810.182KT00	1800	1.0/0.25	2.800	0.21
SH.0810.202KT00	2000	1.0/0.25	3.250	0.20
SH.0810.222KT00	2200	1.0/0.25	3.300	0.19
SH.0810.272KT00	2700	1.0/0.25	5.000	0.17

Isat电流：指使电感量比初始值下降10%Max (The rated DC current is that which cause at 10%Max inductance reduction from the initial value)

文件编号 File Number	SRD-WI-14783	版本号 Version Number	A	页码 page	3 / 6
---------------------	--------------	-----------------------	---	------------	-------

4、材料清单Material List

序号 No.	材 料 material	规 格 Specification	UL NO.	耐热性flame	供应商Supplier
1	磁 芯 Core	DR2W08*10mm B3.5	NA	NA	汇磁或同等
2	线 材 Wire	2UWE-Φ0.15mm	E229423	155°C	鹏成或同等
3	套管 Case	Φ9*12mm/PE	E209436	130°C	三联或同等
4	焊 料 Solder	Sn99.3-Cu0.7	NA	NA	千岛

备 注	注意事项:
	1: 袋装: 500 PCS/袋
	2: 包装袋封口平整。

*NA: Not Applicable.

5、工作和存储条件: Operating and Storage Conditions

工作温度Operating temperature rang: -25 °C to +105°C (Including Self-heating)

存储温度Storage temperature rang: -25 °C to +85°C

相对湿度relative humidity: 30%~85%RH

文件编号 File Number	SRD-WI-14783	版本号 Version Number	A	页码 page	4 / 6
---------------------	--------------	-----------------------	---	------------	-------

6、可靠性测试 Reliability Test

6.1端子拉力强度: Tensile strength of terminal

将被测线圈固定, 用夹具夹住引出端, 按照表相应的拉力大小沿轴向方向缓缓施加 30 ± 5 秒拉力后, 电性能必须无变化, 端子必须无异常。

Fix the coil and than pull the respective terminal. In it, s lead out direction by gradually increasing the tensile force until it reaches the corresponding Value specified in Table .when this tensile force applying state held continuously for 30 ± 5 seconds thereafter, the electrical performance specified must not deteriorate, and the terminal and the coil must not become abnormal.

公称截面积 Nominal section area (mm ²)	公称线径 Nominal wire diameter (mm)	拉力强度 Tensile strength	保持时间 Keeping time (S)
$0.07 \leq S \leq 0.2$	$0.3 \leq d \leq 0.5$	5N	30 ± 5
$0.2 < S \leq 0.5$	$0.5 < d \leq 0.8$	10N	30 ± 5
$0.5 < S \leq 1.0$	$0.8 < d \leq 1.2$	25N	30 ± 5
$1.0 < S$	$1.2 < d$	45N	30 ± 5

6.2端子弯曲强度: Bending strength of lead wire terminal

①软铜线或相等的端子 Annealed copper wire or equivalent terminal

将被测线圈引出端固定, 线圈保持垂直, 按照表规定的重量将线圈弯曲 90° 后, 返回到原点, 再向相反方向弯曲 90° 后返回到原点为一个周期, 每个周期操作时间为 5 秒, 共测试两个周期, 试验后, 端子应无异常破坏和其它损伤现象。

Maintain the coil in such that proper leader axle of the lead wire perpendicularly and hang the Specified weight as showed in Table and after bending the coil 90 degree, return to the original position .This shall complete in 5 seconds, and count as 1 time and do the same towards opposite side which count as 2 time. Do not get the lead wire tduring the test. After the test ,there must be no abnormality such as breakage and etc.

②硬铜线或相等端子 Hard drawn copper wire or equivalent terminal

没有松动和断裂。

Has no looseness, and rattle.

公称截面积 Nominal section area (mm ²)	公称线径 Nominal wire diameter (mm)	弯曲力 Mass of weight (kg)
$0.07 \leq S \leq 0.2$	$0.3 \leq d \leq 0.5$	0.25
$0.2 < S \leq 0.5$	$0.5 < d \leq 0.8$	0.50
$0.5 < S \leq 1.0$	$0.8 < d \leq 1.2$	1.00
$1.0 < S$	$1.2 < d$	1.50

6.3振动试验 Vibration test

根据下表的测试条件进行试验后, 在标准状态下放置 1 小时以上 2 小时以内, 必须无异常现象。

After doing following test under it, s using condition or in the same installed condition and leave it as standard condition for more than 1 hour but less that 2 hours. There must be no abnormality

振动频率 Vibration frequency	变化周期 Changing frequency	振幅 Amplitude	时间 Time
10~55Hz	1 分钟 1minute	1.5mm	X、Y 和 Z 方向各 2 小时 2 hours each Direction of X、Y and Z

文件编号 File Number	SRD-WI-14783	版本号 Version Number	A	页码 page	5 / 6
<p>6.4 跌落试验 Drop test</p> <p>从高度为1米的空中自由落地到混凝土地板重复10次必须无异常。 Drop 10 times on a concrete floor from a high of 1m there must be no abnormality.</p>					
<p>6.5 可焊性 Soldering ability</p> <p>将端子浸入助焊剂中 5~10 秒然后浸入 245±5°C的焊锡槽中 2.5±0.5 秒钟取出,端子必须完全焊锡,并且包装发出的产品保证 6 个月,未包装的产品放置 3 个月,端子必须满足可焊性。 Soak the respective terminal in flux continuously for 5~10 seconds, and then soak the same terminal in molten solder at 245±5°C continuously in a solder bath continuously for 2.5±0.5 seconds After that, the terminal must have soldered properly Also the standard must be met after 6 months period of outgoing packing condition and after 1 months period of unpacked condition.</p>					
<p>6.6 耐焊接热 Soldering heat resistance</p> <p>将端子根部以下 2~2.5mm 浸入助焊剂中 5~10 秒再浸入 350±10°C的焊锡槽中 3+1 秒,然后将零件放置在标准状态下 1 小时以上 2 小时以内,必须满足电性能和机械性能。 Soak the respective terminal in flux continuously for 5~10 seconds, and then dip the terminal up to 2~2.5mm from the root in the solder bath of solder bath of solder at 350±10°C for 3+1 seconds. After that, leave it as standard condition for more than 1 hour but less than 2 hours and must satisfy in electrical performance and mechanical performance.</p>					
<p>6.7 耐热性 Heat Resistance</p> <p>将被测零件放置在 85±2°C 的恒温箱中 96±4 小时后,在标准状态下放置 1 小时以上 2 小时以内测量,电性能和机械性能应无异常。 After leave as no load in the constant temperature at 85±2°C for 96±4 hours, leave as standard condition for more than 1 hour but less than 2 hours and measure. Electrical performance and mechanical performance shall stay normal.</p>					
<p>6.8 耐寒性 Cold Resistance</p> <p>将被测零件放置-25±2°C的恒温箱中 96±4 小时后,在标准状态下放置 1 小时以上 2 小时以内测量,电性能和机械性能应无异常。 After leave as no load in the constant temperature at -25±2 °C for 96±4 hours, leave as standard condition for more than 1 hour but less than 2 hours and measure. Electrical performance and mechanical performance shall stay normal.</p>					
<p>6.9 耐湿热 Damp heat resistance</p> <p>将被测零件放置在 40±2°C 相对湿度为 90~95% 恒温恒湿的箱中,96±4 小时后,在标准状态下放置 1 小时以上 2 小时以内测量,电性能和机械性能应无异常。 After leave as no load in the constant temperature humidity oven of relative humidity 90~95% at 40±2°C for 96±4 hours, leave as standard condition for more than 1 hour but less than 2 hours and measure. Electrical performance and mechanical performance shall stay normal.</p>					
<p>6.10 热冲击 Heat shock</p> <p>将被测零件无负荷放置在-25±2°C的恒温箱中 30 分钟,立即转入 85±2°C的恒温箱中 30 分钟为一个循环,共 5 个循环后在标准状态下放置 1 小时以上 2 小时以内测量,电性能和机械性能应无异常。 After leave as no load in the constant temperature oven at -25±2°C for 30 minutes, immediately leave as no load in the constant temperature oven at 85±2°C for 30 minutes. Which is said to 1 cycle and after 5 cycles, leave as standard condition for more than 1 hour but less than 2 hours and measure. Electrical performance and mechanical performance shall stay normal.</p>					

文件编号 File Number	SRD-WI-14783	版本号 Version Number	A	页码 page	6 / 6
---------------------	--------------	-----------------------	---	------------	-------

7、注意事项 Note

①本承认书保证我司产品作为一个单体时的质量情况。当我司产品被安装到贵司产品上时，请保证贵司的产品已根据贵司的规范进行了有效评估和确认。

This product specification guarantees the quality of our product as a single unit. Please make sure that your product is evaluated and confirmed against your specifications when our product is mounted to your product.

②如果贵司对我司产品的使用已超过了本承认书所界定的产品功能，那么对于由此引发的失效，我司将不予保证。

We cannot warrant against failure caused by any use of our product that deviates from the intended use as described in this product specification.

③为了保持终端电极的焊接性，并使包装材料保持良好状态，必须控制储存区的温度和湿度。
To maintain the weldability of terminal electrodes and to keep the packing material in good condition, temperature and humidity in the storage area should be controlled.

※建议的条件：-10 ~ +40℃，10~90%RH.

Recommended conditions: -10 ~ +40℃，10~90%RH.

※储存超过六个月的，应在实际使用前进行焊接检验。

In case of storage over 6 months, solderability shall be checked before actual usage.

※即使在理想的储存条件下，产品的可焊性也随着时间的推移而降低。因此，产品应从交货时算起，建议8个月之内使用完。

Even under ideal storage conditions, the solderability of the product decreases over time.

therefore, the product should be From the time of delivery, it is recommended that it be used within 8 months.

④本承认书在客户收到30天之内，必须签章返回，逾期视为默认。

The Specification Approval should be sent back to the supplier with customer's chop on it within 30 days after receiving it, or we will take it as approved by customer's automatically.

⑤如有特殊规格要求，请事前联络我司技术部人员。

In case of special specifications please contact our technical department prior staff.