

REV.	ECN.NO.	MODIFY.CONTENT	DATE
A0		NEW	2013.02.29

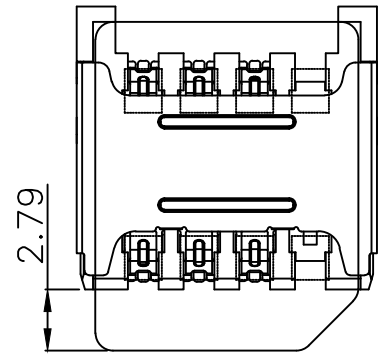

INSERT CARD

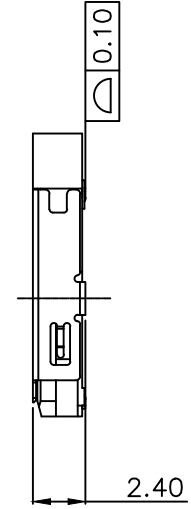
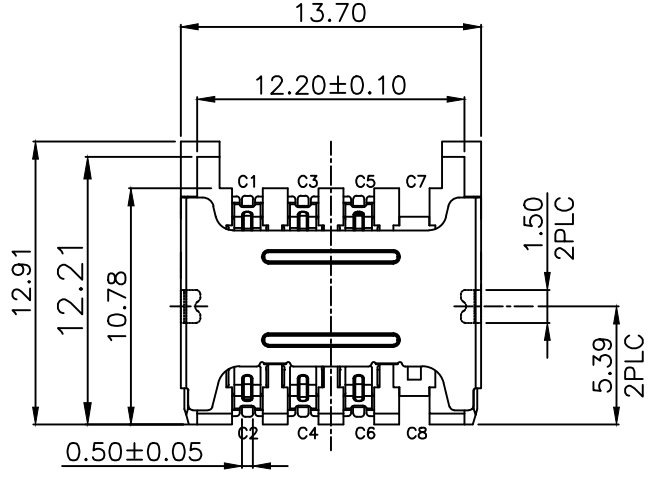
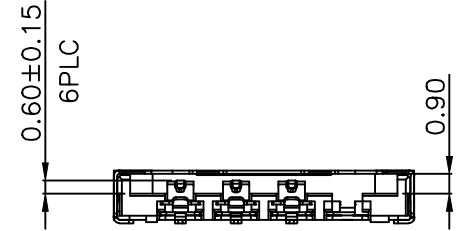

NOTES:
 1)MATERIAL:
 HOUSING: LCP UL 94V-0
 CONTACT: COPPER ALLOY
 SHELL: STAINLESS STEEL
 2)FINISH :
 CONTACT:GOLD FLASH PLATED ON CONTACT AREA;
 GOLD FLASH PLATING ON SOLDER TAILS,
 WITH ENTIRE CONTACT UNDERPLATED NICKEL
 SHELL: NICKEL UNDERPLATED OVERALL,
 GOLD FLASH PLATED ON SOLDER TAILS

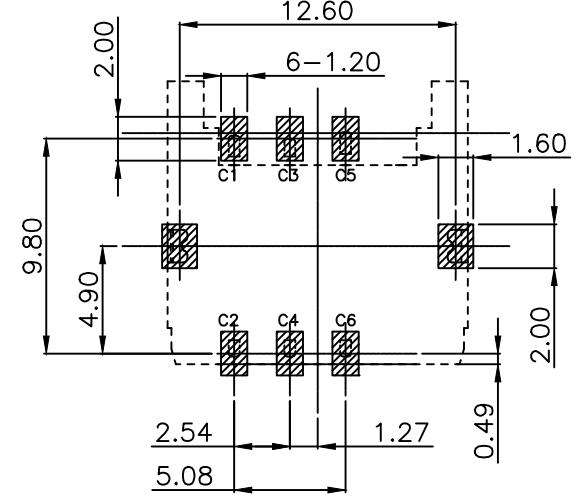

RECOMMENDED PCB LAYOUT(TOP VIEW)
 GENERAL TOLERANCES:±0.05

MICRO SIM CARD	
PIN NO.	DESCRIPTION
C1	VCC
C3	RST
C5	CLK
C7	RES
C2	GND
C4	VPP
C6	I/O
C8	RES

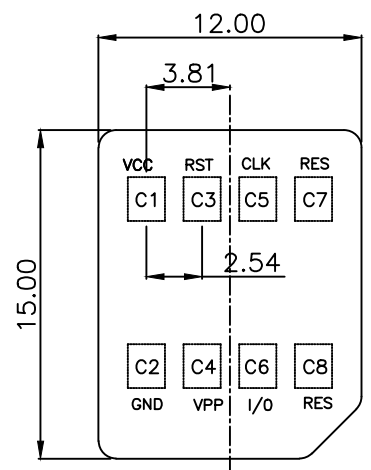

MICRO SIM CARD
 芯片面朝下视图

GENERAL TOLERANCE	图号	设计	比例	1:1	
X.±0.30	x.'±5'	品名	MICRO SIM 2.40H 6PIN CARD CONN.	单位	mm
.X±0.25	.x'±2'			核准	视角
.XX±0.15	.xx'±1'	料号	5001B-SIM240-170	日期	2013/02/29
.XXX±0.10	.xxx'±0.5'	日期	2013/02/29	版本	A0
页数	1/2	东莞市文章济美电子有限公司			

REV.	ECN.NO.	MODIFY.CONTENT	DATE
AO		NEW	2013.02.29

<图一>

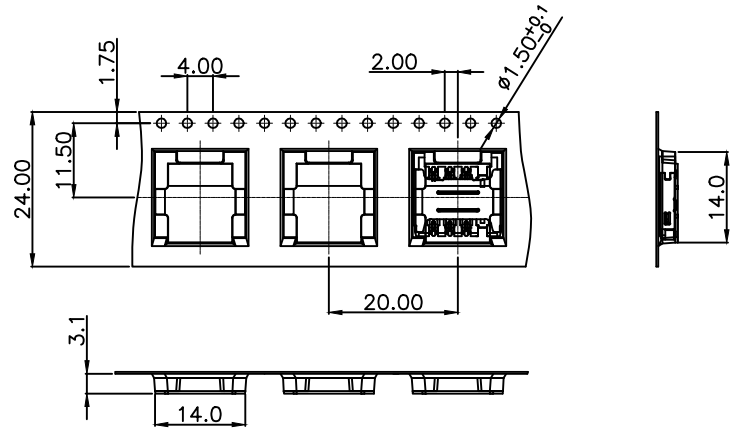

<TABLE 1> PACKAGING QUANTITY

QTY/REEL	REEL/CARTON	QTY/CARTON
1000	10	10000

<图三>

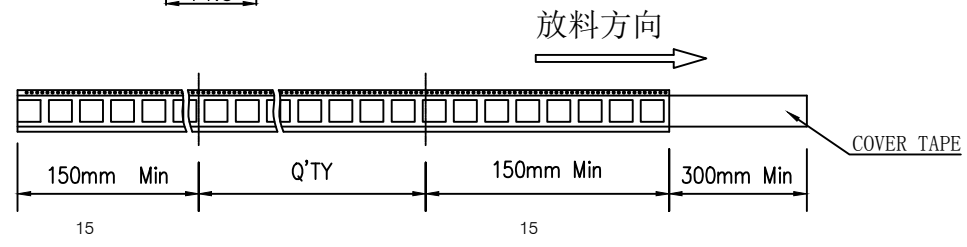
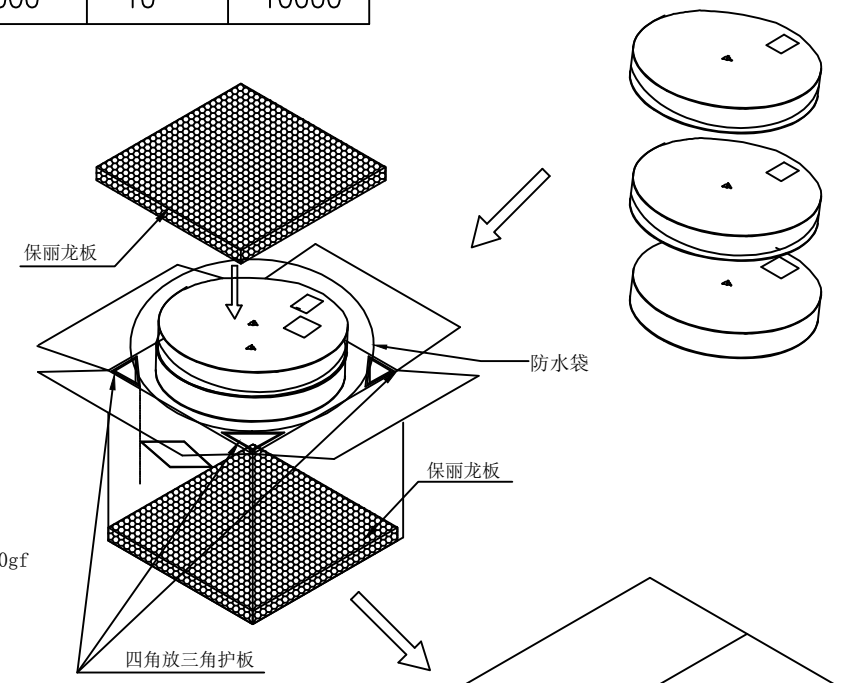

<图二>

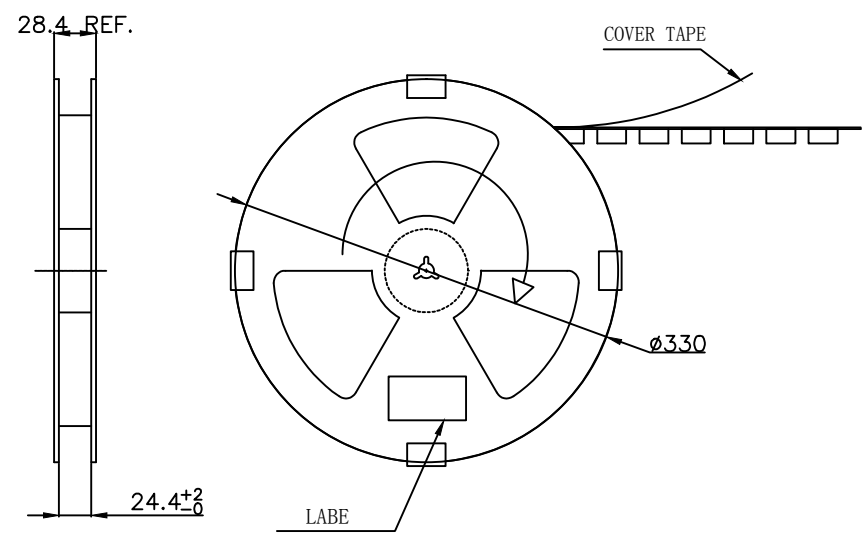

COVER TAPE PEELING FORCE: 50gf~150gf

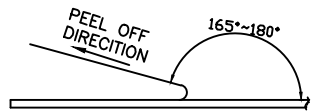

NOTE:

- 依<图一>示放置产品于下载中, 每穴放置1PCS产品.
- 包装机包好后, 在REEL的个等分点贴上胶带, 以防止REEL张开, 每REEL贴1PCS标签, 如<图二>示
- 包装数量见如<TABLE 1>示
- 包装成箱见如<图三>示
箱底放保利龙板, 再依次将指定数量的卷装产品用防水袋包好放入箱内, 四角分别放入四个三角护板, 最上层再放上保利龙板.
- 封箱, 在封好的纸箱上按客户要求写上料号, 数量等

GENERAL TOLERANCE		图号	设计		比例	1:1	
X.±0.45	x.±5'	品名	MICRO SIM 2.40H 6PIN CARD CONN.包装图		审核	单位	mm
.XX±0.35	.xx±2'		核准				
.XX±0.25	.xx±1'	料号	5001B-SIM240-170	日期	2013/02/29		
.XXX±0.15	.xxx±0.5'						
页号	2/2	东莞市文章济美电子有限公司					