

# UNIVERSAL FLASH STORAGE

(UFS 2.2)

---

UFS64G-TY7B-01A11

v1.0

Kingston Digital Inc.

## CONTENTS

<b>Product Features :</b>	<b>3</b>
<b>1 Introduction</b>	<b>4</b>
<b>2 Specification</b>	<b>4</b>
2.1 Device Summary	4
2.2 System Performance	4
2.3 Power Consumption	5
2.4 Device and Partition capacity	5
<b>3 Mechanical Specification</b>	<b>6</b>
3.1 Ball Definition	6
3.2 Package Dimension (11.5mm*13mm )	8
3.3 UFS Block Diagram	9
3.4 Reference Clock	10
3.4.1 Reference Clock	11
3.5 Power Mode	11
3.5.1 Active Power Mode	12
3.5.2 Idle Power Mode	12
3.5.3 Pre-Active Power Mode	13
3.5.4 UFS-Sleep Power Mode	13
3.5.5 Pre-Sleep Power Mode	14
3.5.6 UFS-PowerDown Power Mode	14
3.5.7 Pre-PowerDown Power Mode	14
3.5.8 Responses to SCSI commands	15
3.5.9 Responses to SCSI commands (cont'd)	16
<b>4 UFS SCSI Domain</b>	<b>17</b>
4.1 UFS Logical Unit Definition	17
4.2 SCSI Command	18
<b>5 UFS Supported Pages</b>	<b>19</b>
5.1 Control Mode Page	19
5.2 Read-Write Error Recovery Mode Page	22
5.3 Caching Mode Page	24
5.4 Caching Mode Page Parameters	25
5.5 Vital product data parameters	25
5.5.1 Overview	25
5.5.2 VPD page format	26
5.5.3 Supported VPD Pages VPD page	27
5.5.4 Mode Page Policy VPD page (cont'd)	29
<b>6 Marking</b>	<b>30</b>
<b>7 Revision History</b>	<b>31</b>

## Product Features :

### <Common>

- Packaged NAND flash memory with UFS 2.2 interface
- Compliant with UFS Specification Ver.2.2
- Support for High Speed Gear Rates : Up to HS-GEAR3 (2 lane)
  - PWM : supports to Gear 1~7
  - HS-BURST: supports to Gear 1~3
- UFS layering :
  - UFS Command Set Layer (UCS)
  - UFS Transport Protocol Layer (UTP)
  - UFS Interconnect Layer (UIC)
- Temperature :
  - Operation : -25°C ~ 85°C
- Operating voltage :
  - VCCQ2= 1.8V(Typ) , VCC = 3.3 V(Typ)
- Error free memory access
  - Internal error correction code (ECC) to protect data communication
  - Internal enhanced data management algorithm
  - Solid protection of sudden power failure safe-update operations for data content
- Security
  - Discard
  - Replay Protected Memory Block (RPMB)
  - Support secure bad block erase commands
  - Enhanced write Protection with permanent and partial protection options
- Performance
  - High Priority Interrupt
  - Background Operation
  - Command Queuing
  - Data tag
  - Context ID
  - Cache Operation
  - Write booster
- Reliability
  - Dynamic Capacity
  - Real Time Clock
  - Production State Awareness (PSA)
- Quality
  - RoHS compliant (for detailed RoHS declaration, please contact your KSI representative.)
- Similar functional features as eMMC.
  - Multiple logical units with configurable characteristics
  - Reliable write operation
  - Task management
  - Device Health (EOL)
  - Field Firmware Update(FFU)

# 1 Introduction

Kingston UFS products follow the JEDEC UFS 2.2 standard. It is an ideal universal storage solution for many electronic devices, including smartphones, camera, Tablets, Electronic toys, Smart home, Wearable, Automotive sensor, Artificial intelligence robotics, Virtual reality (VR), Unmanned aerial vehicle that require mass storage. UFS encloses the 3D NAND and UFS controller inside as one JEDEC standard package, providing a standard interface to the host. The UFS controller directly manages NAND flash, including ECC, wear-leveling, IOPS optimization and read sensing.

# 2 Specification

## 2.1 Device Summary

Product Part Number	NAND Density	Package	Operating voltage
UFS64G-TY7B-01A11	64GB	FBGA153	V <sub>CC</sub> = 2.7V~3.6V V <sub>CCQ2</sub> =1.7V~1.95V

## 2.2 System Performance

Products	Write Booster value	
	Sequential Read (MB/s)	Sequential Write (MB/s)
UFS64G-TY7B-01A11	810	510

Note 1: For performance number under other test conditions, please contact KSI representatives.  
 Note 2: Performance numbers might be subject to change without notice.

Products	Typical value	
	Sequential Read (MB/s)	Sequential Write (MB/s)
UFS64G-TY7B-01A11	810	85

Note 1: For performance number under other test conditions, please contact KSI representatives.  
 Note 2: Performance numbers might be subject to change without notice.

### 2.3 Power Consumption

Products	Read(mA)		Write(mA)		Idle(uA)		Sleep(uA)	
	V <sub>CCQ2</sub> (1.8V)	V <sub>CC</sub> (3.3V)	V <sub>CCQ2</sub> (1.8V)	V <sub>CC</sub> (3.3V)	V <sub>CCQ2</sub> (1.8V)	V <sub>CC</sub> (3.3V)	V <sub>CCQ2</sub> (1.8V)	V <sub>CC</sub> (3.3V)
<b>UFS64G-TY7B-01A11</b>	475	135	400	135	645	25	600	25(0)

Note 1: Values given for an 2 lane bus width, a clock frequency of 26MHz(HS-Gear3),100ms RMS current value, V<sub>CC</sub>= 3.3V±5%, V<sub>CCQ2</sub>=1.8V±5%, T<sub>a</sub> = 25°C

Note 2: Idle current is measured at V<sub>CC</sub>=3.3V±5% , 2 lane bus width without clock frequency.

Note 3: Idle = Hibernate State

Note 4: Sleep = SSU(Sleep) + Hibernate. When in sleep state, V<sub>CC</sub> could be turned off and value will be 0.

Note 5: Current numbers might be subject to change without notice.

### 2.4 Device and Partition capacity

Product	User Density	Boot partition 1	Boot partition 2	RPMB
<b>UFS64G-TY7B-01A11</b>	64034439168 Bytes	4 MB	4 MB	16 MB

### 3 Mechanical Specification

#### 3.1 Ball Definition

Table 3-1 FBGA153 Ball information

Name	Type	Description
VCC	Supply	Supply voltage for the memory devices
VCCQ	Supply	Supply voltage used typically for the memory controller and optionally for the PHY interface, the memory IO, and any other internal very low voltage block
VCCQ2	Supply	Supply voltage used typically for the PHY interface and the memory controller and any other internal low voltage block
VDDiQ	Input	Input terminal to provided bypass capacitor for VCCQ internal regulator
VDDiQ2	Input	Input terminal to provide bypass capacitor for VCCQ2 internal regulator
VDDi	Input	Input terminal to provide bypass capacitor for VCC internal regulator
VSS	Supply	Ground
RST_n	Input	Input hardware reset signal. This is an active low signal
REF_CLK	Input	Input reference clock. When not active, this signal should be pull-down or driven low by the host SoC.
Differential input signals into UFS device from the host		
DIN_t or DIN0_t DIN_c or DIN0_c	Input	Downstream data lane 0 DIN_t is the positive node of the differential signal.
DIN1_t, DIN1_c	Input	Downstream data lane 1
Differential output signals from the UFS device to the host		
DOUT_t or DOUT0_t DOUT_c or DOUT0_c	Output	Downstream data lane 0 DOUT_t is the positive node of the differential signal.
DOUT1_c, DOUT1_c	Output	Upstream data lane 1
NC		No connect. Need Keep floating.
VSF		Vendor Specific Function. Need Keep floating.
RFU		No connect. Reserved for future use. Need Keep floating.

Figure 3-1 Ball assignment for FBGA 153L

<b>UFS2.x</b>															
	1	2	3	4	5	6	7	8	9	10	11	12	13	14	
A	NC	NC	VDDIQ	NC	NC	VCCQ2	VCCQ2	VDDIQ2	VDDi	NC	NC	NC	NC	NC	A
B	NC	VSS	RFU	NC	NC	VCCQ2	VCCQ2	VCC	VCC	NC	VSS	VSS	RFU	NC	B
C	VSS	VSS	VSS	NC	NC	VCCQ2	VCCQ2	VCC	VCC	RFU	VSS	VSS	RFU	RFU	C
D	DIN1_t	DIN1_c	VSS	NC								VSS	VSS	VSS	D
E	VSS	VSS	VSS		NC	VSF1	VSF2	VCC	VSF3	VSF4		VSS	RFU	RFU	E
F	DIN0_t	DIN0_c	VSS		NC					VSF5		VSS	VSS	VSS	F
G	VSS	VSS	VSS		VSF6					VSS		VSS	RFU	RFU	G
H	REF_CLK	RST_n	VSS		VSS					VSS		VSS	VSS	VSS	H
J	VSS	VSS	VSS		VSS					VSF7		VSS	RFU	RFU	J
K	DOUT0_c	DOUT0_t	VSS		VSS	VCCQ2	VCCQ2	VCC	NC	VSF8		VSS	VSS	VSS	K
L	VSS	VSS	VSS									VSS	RFU	RFU	L
M	DOUT1_c	DOUT1_t	VSS	VSS	VSS	RFU	RFU	NC	NC	RFU	NC	VSS	VSS	VSS	M
N	NC	VSS	VSS	VSS	VSS	RFU	RFU	VCC	VCC	RFU	VSS	VSS	RFU	NC	N
P	NC	NC	RFU	VSS	VSS	RFU	RFU	VCC	VCC	VSF9	VSS	VSS	NC	NC	P
	1	2	3	4	5	6	7	8	9	10	11	12	13	14	

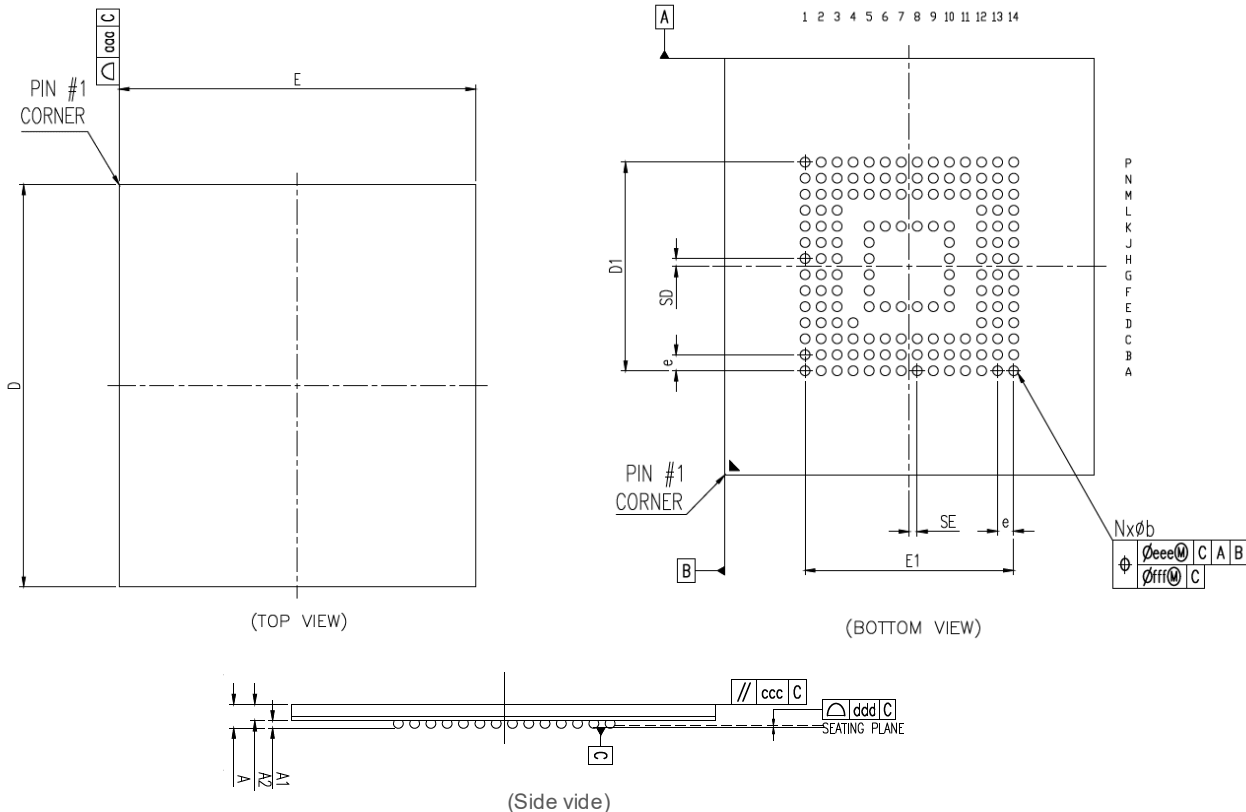
**3.2 Package Dimension (11.5mm\*13mm)**

SYMBOL	DIMENSION IN MM			DIMENSION IN INCH		
	MIN.	NOM.	MAX.	MIN.	NOM.	MAX.
A	0.625	0.735	0.80	0.025	0.029	0.031
A1	<b>0.15</b>	0.225	0.27	<b>0.006</b>	0.009	0.011
A2	0.45	0.51	0.57	0.018	0.020	0.022
b	0.25	0.30	0.35	0.010	0.012	0.014
D	12.90	13.00	13.10	0.508	0.512	0.516
E	11.40	11.50	11.60	0.449	0.453	0.457
e	0.50 BSC.			0.020 BSC.		
JEDEC	MO-276(REF.)/MM					
aaa	0.15					
ccc	0.20					
ddd	0.08					
eee	0.15					
fff	0.05					
N	SE (mm)	SD (mm)	E1 (mm)	D1 (mm)		
153L	0.25 BSC.	0.25 BSC.	6.50 BSC.	6.50 BSC.		

### 3.3 UFS Block Diagram

Figure 3.2 represents a conceptual drawing of UFS device. Utilization of internal regulators and Connection of those to different parts of the sub-system may differ per implementation.

Figure 3-2 Device Block diagram

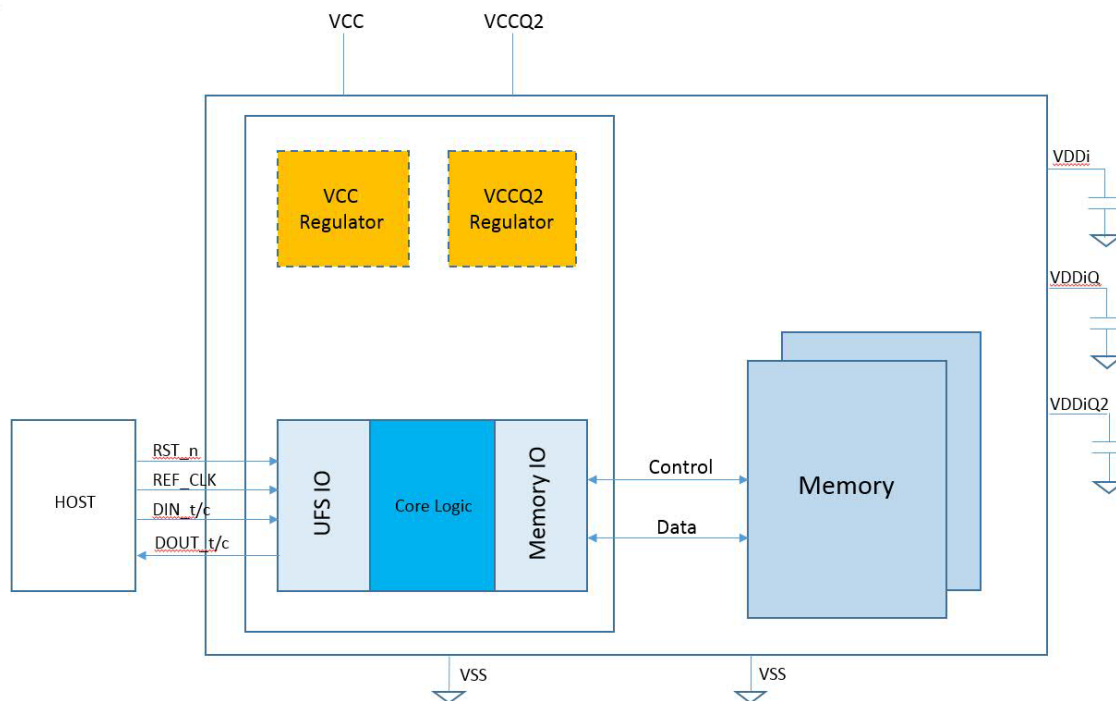

Table 3-2 - Power Supply Parameter

Parameter	Symbol	Min	Max	Unit	Notes
VCC DC operating range	VCC	2.7	3.6	V	
VCCQ2 DC operating range	VCCQ2	1.70	1.95	V	
Supply Voltage power up timing for 3.3 V	tPRUH		35	ms	1
Supply Voltage power up timing for 1.8 V	tPRUL		25	ms	1
VCC internal regulator capacitor	CVDDi	1		μF	
VCCQ2 internal regulator capacitor	CVDDiQ	1		μF	
NOTE 1 Power up timing starts when the supply voltage crosses 300 mV and ends when it reaches the minimum operating value.					

### 3.4 Reference Clock

The M-PHY specification defines the reference clock optional for the State Machine Type I [MIPI M-PHY]. As the PWM signaling is self-clocked the reference clock is not required for the data latching. Therefore, UFS devices shall be able to operate without reference clock in LS-MODE (LINE-CFG, SLEEP and PWM-BURST).

Still existence of the reference clock may be utilized to enable lower BER and faster HS-MODE PLL/DLL locking. Thus a UFS device shall implement a square wave single ended reference clock input and it requires the presence of a reference clock with the characteristics described in this section when operating in HS-MODE (STALL and HS-BURST). In order to avoid potential race conditions, it is recommended that such reference clock is already present when requesting a power mode change into Fast\_Mode or FastAuto\_Mode.

Table 3-3 – Reference Clock

Parameter	Symbol	Min	Max	Unit	Notes	
Frequency	$f_{ref}$	19.2 26(Default)		MHz	1	
Frequency Error	$f_{ERROR}$	-150	+150	ppm		
Input High Voltage	$V_{IH}$	0.65 * VCCQ		V	2	
Input Low Voltage	$V_{IL}$	0.35 * VCCQ		V	2	
Input Clock Rise Time	$t_{RISE}$	2		ns	3	
Input Clock Fall Time	$t_{FALL}$	2		ns	3	
Duty Cycle	$t_{DC}$	45	55	%	4	
Phase Noise	N			-66	dBc	5
Noise Floor Density	$N_{density}$			-140	dBc/H	6
Input Impedance	$RL_{RX}$	100		k $\Omega$	7	
	$CL_{RX}$	5		pF		
<p>NOTE 1 HS-BURST rates A and B are achieved with integer multipliers of <math>f_{ref}</math>.</p> <p>NOTE 2 Figure 3-3 shows the input levels <math>V_{IL,MAX}</math> to <math>V_{IH,MIN}</math>.</p> <p>NOTE 3 Clock rise time and clock fall time shall be measured from 20% to 80% of the window defined by <math>V_{IL,MAX}</math> to <math>V_{IH,MIN}</math>, see Figure 3-3.</p> <p>NOTE 4 Clock duty cycle shall be measured at the crossings of the REF_CLK signal with the midpoint <math>V_{MID}</math>, defined as: <math>V_{MID} = (V_{IL,MAX} + V_{IH,MIN}) / 2</math>, see Figure 3-3.</p> <p>NOTE 5 Integrated single side band phase noise from 50kHz to 10MHz. This parameter refers to the random jitter only.</p> <p>NOTE 6 White noise floor. This parameter refers to the random jitter only.</p> <p>NOTE 7 <math>RL_{RX}</math> and <math>CL_{RX}</math> include Rx package and Rx input impedance.</p>						

### 3.4.1 Reference Clock

Figure 3-3- Clock input levels, rise time and fall time

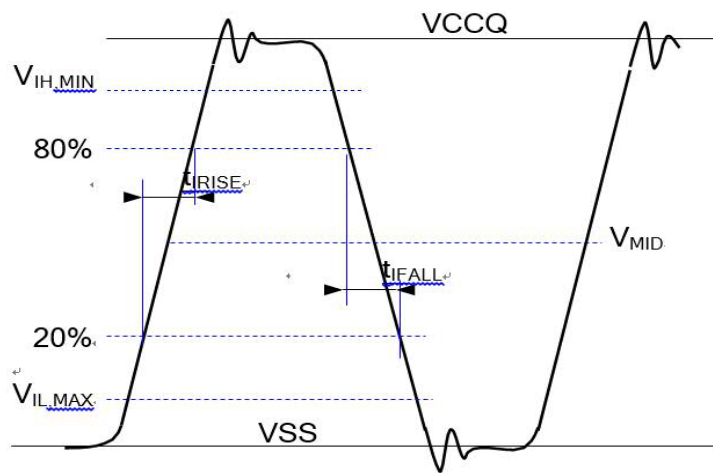

### 3.5 Power Mode

The UFS device support multiple power mode which controlled by the START STOP UNIT command and some attributes. UFS will support seven power mode (Active, Idle, Pre-active, UFS sleep, Pre-sleep, UFS-PowerDown, Pre-Power down) defined by JEDEC UFS2.2 specification.

Figure 3-4- Power Mode state Machine

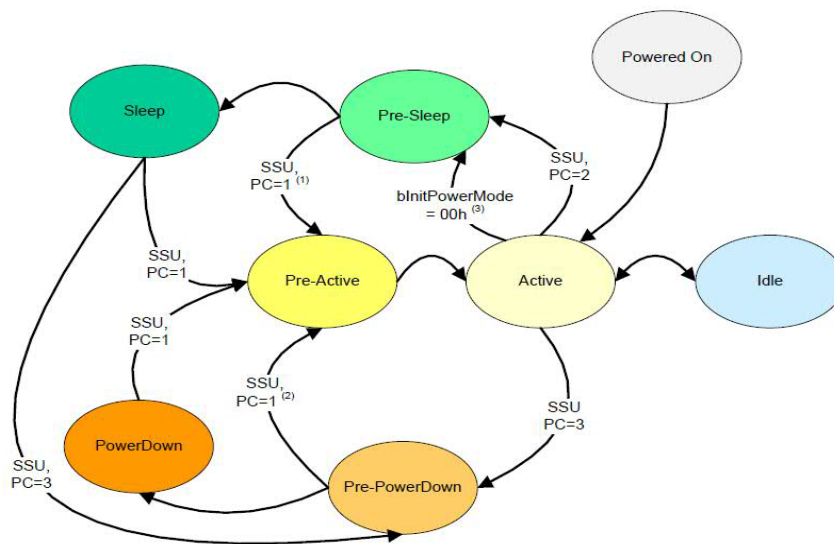

- (1) This transition may occur only if the SSU command that caused the transition to Pre-Sleep had IMMED set to one.
- (2) This transition may occur only if the SSU command that caused the transition to Pre-PowerDown had IMMED set to one.
- (3) This automatic transition shall occur at the end of device initialization if bInitPowerMode = 00h.

### 3.5.1 Active Power Mode

Valid values for the bActiveICCLevel are from “00h” to “0Fh”, other values are reserved and should not be set.

UFS devices should primarily use settings of “06h” and “0Ch”, for normal (battery) and high (plugged in) power operating modes.

The bInitActiveICCLevel parameter in the Device Descriptor allows the user to configure the Active ICC level after power on or reset.

The bInitPowerMode parameter in the Device Descriptor defines the power mode to which the device shall transition to after completing the initialization phase (fDeviceInit cleared to zero).

Active Mode can be entered from the Powered On mode or the Pre-Active mode after the completion of all setup necessary to handle commands.

The following power mode may be: Idle, Pre-Sleep, or Pre-PowerDown.  
All supported commands are available in Active Mode.

### 3.5.2 Idle Power Mode

The Idle power mode is reached when the device is not executing any operation. In general, the M-PHY interface may be in STALL, SLEEP or HIBERN8 state. If background operations are continuing, the device should be considered Active power mode.

This mode can only be entered from an Active power mode, and the following state is always the Active power mode. The receipt of any command will transition the device into Active power mode.

### 3.5.3 Pre-Active Power Mode

The Pre-Active power mode is a transitional mode associated with Active power mode. The power consumed will be no more than that consumed in Active power mode. The device shall remain in this power mode until all of the preparation needed to accept commands has been completed.

Pre-Active power mode can be entered from Pre-Sleep, Sleep, Pre-PowerDown, or PowerDown. The following power mode is the Active power mode.

- a. The Device well known logical unit may successfully complete only: START STOP UNIT command and REQUEST SENSE command; other commands may be terminated with CHECK CONDITION status, with the sense key set to NOT READY, with the additional sense code set to LOGICAL UNIT IS IN PROCESS OF BECOMING READY. See table 3-4 for further detail.
- b. A REQUEST SENSE command shall be terminated with GOOD status and provide pollable sense data with the sense key set to NO SENSE, and the additional sense code set to LOGICAL UNIT TRANSITIONING TO ANOTHER POWER CONDITION.

### 3.5.4 UFS-Sleep Power Mode

The UFS-Sleep power mode allows to reduce considerably the power consumption of the device.

VCC powersupply can be removed in this state.

The UFS-Sleep power mode is entered from Pre-Sleep power mode.

While in UFS-Sleep power mode:

- a. the Device well known logical unit may successfully complete only: START STOP UNIT command and REQUEST SENSE command; other commands may be terminated with CHECK CONDITION status, with the sense key set to NOT READY and the additional sense code set to LOGICAL UNIT NOT READY, INITIALIZING COMMAND REQUIRED. See table 3-4 for further detail.
- b. REQUEST SENSE command shall be terminated with GOOD status and provide pollable sense data with the sense key set to NOT READY and the additional sense code set to LOGICAL UNIT NOT READY, INITIALIZING COMMAND REQUIRED.

It is recommended to put the link in HIBERN8 state, although it is actually under host control and can come up and down independently of the UFS power mode.

VCC power supply should be restored before issuing START STOP UNIT command to request transition to Active power mode or PowerDown power mode.

### 3.5.5 Pre-Sleep Power Mode

The Pre-Sleep Mode is a transitional mode associated with UFS-Sleep entry. The power consumed will be no more than that consumed in Active power mode. Pre-Sleep can be entered from Active power mode.

The device will automatically advance to Sleep power mode once any outstanding operations and management activities have been completed.

The device will transition from Pre-Sleep power mode to Pre-Active power mode if START STOP UNIT command with POWER CONDITION = 1h is issued.

While in Pre-Sleep power mode:

- a. The Device well known logical unit may successfully complete only: START STOP UNIT command, REQUEST SENSE command and task management functions; other commands may be terminated with CHECK CONDITION status, with the sense key set to ILLEGAL REQUEST. See table 3-4 for further detail.
- b. A REQUEST SENSE command shall be terminated with GOOD status and provide pollable sense data with the sense key set to NO SENSE and the additional sense code set to LOGICAL UNIT TRANSITIONING TO ANOTHER POWER CONDITION.

### 3.5.6 UFS-PowerDown Power Mode

The UFS-PowerDown power mode is the maximum power saving mode. All volatile data may be lost and VCC or all power supplies can be removed.

This mode is automatically entered from the Pre-PowerDown power mode, at the completion of the power mode transition.

While in UFS-PowerDown power mode:

- a. The Device well known logical unit may successfully complete only: START STOP UNIT command and REQUEST SENSE command; other commands may be terminated with CHECK CONDITION status, with the sense key set to NOT READY and the additional sense code set to LOGICAL UNIT NOT READY, INITIALIZING COMMAND REQUIRED. See table 3-4 for further detail.
- b. A REQUEST SENSE command shall be terminated with GOOD status and provide pollable sense data with the sense key set to NOT READY, and the additional sense code set to LOGICAL UNIT NOT READY, INITIALIZING COMMAND REQUIRED.

### 3.5.7 Pre-PowerDown Power Mode

The Pre-PowerDown power mode is a transitional mode associated with UFS-PowerDown entry.

The power consumed will be no more than that consumed in Active power mode. Pre-PowerDown can be entered from Active or Sleep.

The device will automatically advance to PowerDown power mode once any outstanding operations and management activities have been completed.

The device will transition to Pre-Active mode if START STOP UNIT command with POWER CONDITION field set to 1h is issued.

The following power mode may be PowerDown or Pre-Active.

While in Pre-PowerDown power mode:

- a. The Device well known logical unit may successfully complete only: START STOP UNIT command REQUEST SENSE command and task management functions; other commands may be terminated with CHECK CONDITION status, with the sense key set to ILLEGAL REQUEST. See table 3-4 for further detail.
- b. A REQUEST SENSE command shall be terminated with GOOD status and provide pollable sense data with the sense key set to NO SENSE and the additional sense code set to LOGICAL UNITTRANSITIONING TO ANOTHER POWER CONDITION.

### 3.5.8 Responses to SCSI commands

Table 3-4 - defines the Device well known logical unit response to a START STOP UNIT command for a given power mode. It is assumed that the IMMED bit in START STOP UNIT commands is set to zero.

Table 3-4 – Device Well Known Logical Unit Responses to SSU command

Current Power Mode	PC	STATUS	SENSE KEY	ASC, ASCQ
Pre-Active	1h	GOOD <sup>(1)</sup>	-	-
	Others	CHECK CONDITION	NOT READY	LOGICAL UNIT NOT READY, START STOP UNIT COMMAND IN
Active	1h, 2h, 3h	GOOD <sup>(1)</sup>	-	-
	Others	CHECK CONDITION	ILLEGAL REQUEST	INVALID FIELD IN CDB
Pre-Sleep	2h	GOOD <sup>(1)</sup>	-	-
	Others	CHECK CONDITION	NOT READY	LOGICAL UNIT NOT READY, START STOP UNIT COMMAND IN
UFS-Sleep	1h, 2h, 3h	GOOD <sup>(1)</sup>	-	-
	Others	CHECK CONDITION	ILLEGAL REQUEST	INVALID FIELD IN CDB
Pre-PowerDown	3h	GOOD <sup>(1)</sup>	-	-
	Others	CHECK CONDITION	NOT READY	LOGICAL UNIT NOT READY, START STOP UNIT COMMAND IN

UFS-PowerDown	1h, 3h	GOOD <sup>(1)</sup>	-	-
	Others	CHECK CONDITION	ILLEGAL REQUEST	INVALID FIELD IN CDB
NOTE 1 The START STOP UNIT command may not terminate with GOOD status for condition not due to CDB content.				

### 3.5.9 Responses to SCSI commands (cont'd)

Table 3-5 - summarizes the response that the Device well known logical unit may provide to a command other than START STOP UNIT for various device power modes.

Table 3-5 - Device Well Known Logical Unit Responses to commands other than SSU

Power Mode	Command	STATUS	SENSE KEY	ASC, ASCQ
Pre-Active	REQUEST SENSE	GOOD <sup>(1)</sup>	-	-
	Others <sup>(1)</sup>	CHECK CONDITION	NOT READY	LOGICAL UNIT IS IN PROCESS OF BECOMING READY
Pre-Sleep, PrePowerDown	REQUEST SENSE	GOOD <sup>(1)</sup>	-	-
	Others <sup>(1)</sup>	CHECK CONDITION	ILLEGAL REQUEST	-
UFS-Sleep, UFS-PowerDown	REQUEST SENSE	GOOD <sup>(1)</sup>	-	-
	Others <sup>(1)</sup>	CHECK CONDITION	NOT READY	LOGICAL UNIT NOT READY, INITIALIZING COMMAND
NOTE 1 Rows identified with "Others" define Device well known logical unit response to command other than START STOP UNIT command and REQUEST SENSE command.				

Table 3-6 defines the pollable sense data for various device power modes.

Table 3-6 Pollable Sense Data for each Power Modes

Power Mode	SENSE KEY	ASC, ASCQ
Pre-Active, Pre-Sleep, Pre-	NO SENSE	LOGICAL UNIT TRANSITIONING TO ANOTHER POWER CONDITION
UFS-PowerDown, UFS-Sleep	NOT READY	LOGICAL UNIT NOT READY, INITIALIZING COMMAND REQUIRED

## 4 UFS SCSI Domain

### 4.1 UFS Logical Unit Definition

Figure 4-1- UFS SCSI Domain

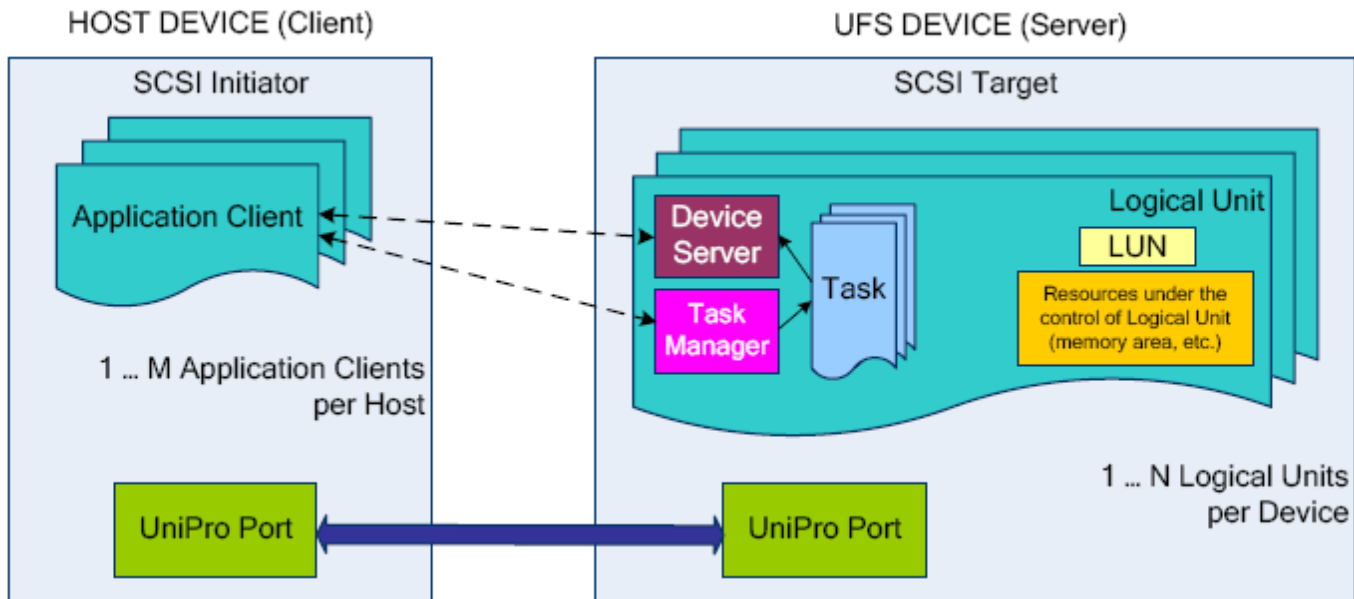

- **1. A logical unit (LU):**  
It is an externally addressable, independent, processing entity that processes SCSI tasks (commands) and performs task management functions.
  - 1.1 Each logical unit is independent of other logical units in a device
  - 1.2 UFS shall support the amount of logical units specified by bMaxNumberLU, in addition to the well known logical units defined in JESD220C\_10.8.5
  - 1.3 logical units may be used to store boot code, application code and mass storage data applications
- **2. DEVICE SERVER:** A conceptual object within a logical unit that processes SCSI commands.
- **3. TASK MANAGER:** A conceptual object within a logical unit that controls the sequencing of commands and performs task management functions.
- **4. TASK SET:** A conceptual group of 1 or more commands (a list, queue, etc.)
- **5. UniPro:**  
It is responsible for management of the link, including the PHY.  
The basic interface to the interconnect layer is UniPro definition of a CPort. CPort is used for all data transfer as well as all control and configuration messages. In general, multiple CPorts can be supported on a device and the number of CPorts is implementation dependent.

## 4.2 SCSI Command

Table 4-1 - UFS SCSI Command Set

Command name	Opcode	Command Support	Support	Note
FORMAT UNIT	04h	M	Yes	
INQUIRY	12h	M	Yes	
MODE SELECT (10)	55h	M	Yes	
MODE SENSE (10)	5Ah	M	Yes	
PRE-FETCH (10)	34h	M	Yes	
PRE-FETCH (16)	90h	O	Yes	
READ (6)	08h	M	Yes	
READ (10)	28h	M	Yes	
READ (16)	88h	O	Yes	
READ BUFFER	3Ch	O	Yes	
READ CAPACITY (10)	25h	M	Yes	
READ CAPACITY (16)	9Eh	M	Yes	
REPORT LUNS	A0h	M	Yes	
REQUEST SENSE	03h	M	Yes	
SECURITY PROTOCOL IN	A2h	M	Yes	
SECURITY PROTOCOL OUT	B5h	M	Yes	
SEND DIAGNOSTIC	1Dh	M	Yes	
START STOP UNIT	1Bh	M	Yes	
SYNCHRONIZE CACHE (10)	35h	M	Yes	
SYNCHRONIZE CACHE (16)	91h	O	No	
TEST UNIT READY	00h	M	Yes	
UNMAP	42H	M	Yes	
VERIFY (10)	2Fh	M	Yes	
WRITE (6)	0Ah	M	Yes	
WRITE (10)	2Ah	M	Yes	
WRITE (16)	8Ah	O	Yes	
WRITE BUFFER	3Bh	M	Yes	
M: mandatory, O: optional, R: RPMB				
NOTE 1 SECURITY PROTOCOL IN command and SECURITY PROTOCOL OUT command are supported by the RPMB well known logical unit.				

## 5 UFS Supported Pages

Table 5-1 shows the mode pages supported by UFS device. This standard does not define any additional subpages.

**Table 5-1 — UFS Supported Pages**

PAGE NAME	PAGE CODE	SUBPAGE CODE	DESCRIPTION
CONTROL	0Ah	00h	Return CONTROL mode page
READ-WRITE ERROR RECOVERY	01h	00h	Return READ-WRITE ERROR RECOVERY mode page
CACHING	08h	00h	Return CACHING mode page
ALL PAGES	3Fh	00h	Return all mode pages (not including subpages)
ALL SUBPAGES	3Fh	FFh	Return all mode pages and subpages

If the device has more than one logical unit, host should read Mode Page Policy VPD in order to know whether the logical unit maintains its own copy of the mode page and subpage or all logical units share the mode page and subpage.

### 5.1 Control Mode Page

The Control mode page provides controls over SCSI features that are applicable to all device types (e.g., task set management and error logging).

Table 5-2 defines the Control mode page default value (PC = 10b).

**Table 5-2 — Control Mode Page default value**

Bit	7	6	5	4	3	2	1	0
Byte 0	PS	SPF (0)	PAGE CODE (0Ah)					
Byte 1	PAGE LENGTH (0Ah)							

2	TST = 000b		TMF_ONL Y = 0b	DPICZ = 0b	D_SENSE = 0b	GLTSD = 0b	RLEC = 0b
3	QUEUE ALGORITHM MODIFIER = 0001b			NUAR = 0b	QERR = 00b	Obsolete = 0b	
4	VS = 0b	RAC = 0b	UA_INTLCK_CTRL = 00b	SWP = 0b	Obsolete = 000b		
5	ATO = 0b	TAS = 0b	ATMPE = 0b	RWWP = 0b	Reserved = 0b	AUTOLOAD MODE = 000b	
6	Obsolete = 0000h						
7							
8	(MSB)	BUSY TIMEOUT PERIOD					(LSB)
9							
10	(MSB)	EXTENDED SELF-TEST COMPLETION TIME					(LSB)
11							
NOTE 1 Default values for PS bit, BUSY TIMEOUT PERIOD field and EXTENDED SELF-TEST COMPLETION TIME field are device specific.							

The following Control mode page field shall be changeable: SWP. The following Control mode page fields are not changeable: TST and BUSY TIMEOUT PERIOD. Other fields may or may not be changeable, refer to the vendor datasheet for details.

**Table 5-3 — Control Mode Page Parameters**

Byte	Bit	Description
1	7:5	<b>TST:</b> Indicates Task Set Type. 000b indicates the logical unit maintains one task set for all I_T nexuses. Others: reserved.
4	3:3	<b>SWP:</b> A software write protect (SWP) bit set to one specifies that the logical unit shall inhibit writing to the medium after writing all cached or buffered write data, if any. When SWP is one, all commands requiring writes to the medium shall be terminated with CHECK CONDITION status, with the sense key set to DATA PROTECT
8:9	7:0	<b>BUSY TIMEOUT PERIOD:</b> The BUSY TIMEOUT PERIOD field specifies the maximum time, in 100 milliseconds increments, that the application client allows for the device server to return BUSY status for commands from the application client. A 0000h value in this field is undefined. An FFFFh value in this field is defined as an unlimited period.
NOTE 1 In addition to the software write protection, logical units may be configured as permanently write protected or power on write protected. A logical unit is writeable if all types of write protection are disabled. Logical units may be write protected setting SWP to one or using one of the methods described in 12.3, Device Data Protection.		

## 5.2 Read-Write Error Recovery Mode Page

The Read-Write Error Recovery mode page specifies the error recovery parameters the device server shall use during any command that performs a read or write operation to the medium (e.g., READ command, WRITE command, or VERIFY command)

Table 5-4 defines the Read-Write Error Recovery mode page default value (PC = 10b).

**Table 5-4 — Read-Write Error Recovery Mode Page default value**

Bit Byte	7	6	5	4	3	2	1	0
0	PS	SPF (0b)	PAGE CODE (01h)					
1	PAGE LENGTH (0Ah)							
2	AWRE = 1b	ARRE = 0b	TB = 0b	RC = 0b	EER = 0b	PER = 0b	DTE = 0b	DCR = 0b
3	READ RETRY COUNT							
4	Obsolete = 00h							
5	Obsolete = 00h							
6	Obsolete = 00h							
7	TPERE = 0b	Reserved = 00000b					Restricted for MMC-6 = 00b	
8	WRITE RETRY COUNT							
9	Reserved = 00h							
10	(MSB)							
11	RECOVERY TIME LIMIT (LSB)							
NOTE 1 Default values for PS field, READ RETRY COUNT field, WRITE RETRY COUNT field and RECOVERY TIME LIMIT are device specific.								

This standard does not define which Read-Write Error Recovery mode page fields are changeable, refer to vendor datasheet for details.

**Table 5-5 — Read-Write Error Recovery Parameters**

Byte	Bit	Description
3	7:0	<b>READ RETRY COUNT:</b> The READ RETRY COUNT field specifies the number of times that the device server shall attempt its recovery algorithm during read operations.
8	7:0	<b>WRITE RETRY COUNT:</b> The WRITE RETRY COUNT field specifies the number of times that the device server shall attempt its recovery algorithm during write operations.
10:11	7:0	<b>RECOVERY TIME LIMIT:</b> The RECOVERY TIME LIMIT field specifies in milliseconds the maximum time duration that the device server shall use for data error recovery procedures. When both a retry count and a recovery time limit are specified, the field that specifies the recovery action of least duration shall have priority.

### 5.3 Caching Mode Page

The Caching mode page defines the parameters that affect the use of the cache. A UFS device shall implement support for following parameters.

Table 5-6 defines the Caching mode page default value (PC = 10b).

**Table 5-6 — Caching Mode Page default value**

Bit	Byte	7	6	5	4	3	2	1	0
0	PS	SPF (0b)	PAGE CODE (08h)						
1	PAGE LENGTH (12h)								
2	IC = 0b	ABPF = 0b	CAP = 0b	DISC = 0b	SIZE = 0b	WCE = 1b	MF = 0b	RCD = 0b	
3	DEMAND READ RETENTION PRIORITY = 0000b				WRITE RETENTION PRIORITY = 0000b				
4	(MSB)	DISABLE PRE-FETCH TRANSFER LENGTH							(LSB)
5	= 0000h								
6	(MSB)	MINIMUM PRE-FETCH							(LSB)
7	= 0000h								
8	(MSB)	MAXIMUM PRE-FETCH							(LSB)
9	= 0000h								
10	(MSB)	MAXIMUM PRE-FETCH CEILING							(LSB)
11	= 0000h								
12	FSW = 0b	LBCSS = 0b	DRA = 0b	Vendor Specific = 00b		Reserved = 00b		NV_DIS = 0b	
13	NUMBER OF CACHE SEGMENTS = 00h								
14	(MSB)	CACHE SEGMENT SIZE							(LSB)
15	= 0000h								
16	Reserved = 00h								
17									
18									
19	Obsolete = 000000h								

The following Caching mode page fields shall be changeable: WCE and RCD. Other fields may or may not be changeable, refer to the vendor datasheet for details

## 5.4 Caching Mode Page Parameters

Table 5-7 — Caching Mode Page Parameters

Byte	Bit	Description
2	2:2	<b>WCE: WRITE BACK CACHE ENABLE.</b> A writeback cache enable bit set to zero specifies that the device server shall complete a WRITE command with GOOD status only after writing all of the data to the medium without error. A WCE bit set to one specifies that the device server may complete a WRITE command with GOOD status after receiving the data without error and prior to having written the data to the medium.
2	0:0	<b>RCD: READ CACHE DISABLE.</b> A read cache disable bit set to zero specifies that the device server may return data requested by a READ command by accessing either the cache or medium. A RCD bit set to one specifies that the device server shall transfer all of the data requested by a READ command from the medium (i.e., data shall not be transferred from the cache).

NOTE 1 Fields that are not supported by UFS should be set to zero, and are documented assigning a value of zero to them (e.g., PS=0b). The device may ignore values in fields that are not supported by UFS.

## 5.5 Vital product data parameters

### 5.5.1 Overview

The vital product data (VPD) pages are returned by an INQUIRY command with the EVPD bit set to one and contain vendor specific product information about a logical unit and SCSI target device.

A UFS device shall support the following VPD pages:

- Supported VPD Pages
- Mode Page Policy

Support for other VPD pages is optional.

### 5.5.2 VPD page format

Table 11-69 shows the VPD page structure.

**Table 5-8 — VPD page format**

Bit Byte	7	6	5	4	3	2	1	0
0	PERIPHERAL QUALIFIER			PERIPHERAL DEVICE TYPE				
1	PAGE CODE							
2	(MSB)	PAGE LENGTH (n-3)						(LSB)
3								
4	(MSB)	VPD parameters						(LSB)
n								

The PERIPHERAL QUALIFIER field and the PERIPHERAL DEVICE TYPE field are the same as defined for standard INQUIRY data (see 11.3.2.2).

The PAGE CODE field identifies the VPD page and contains the same value as in the PAGE CODE field in the INQUIRY CDB (see 11.3.2).

The PAGE LENGTH field indicates the length in bytes of the VPD parameters that follow this field. See [SPC] for further details.

### 5.5.3 Supported VPD Pages VPD page

The Supported VPD Pages VPD page contains a list of the VPD page codes supported by the logical unit (see Table 11-70).

**Table 5-9— Supported VPD Pages VPD page**

Bit Byte	7	6	5	4	3	2	1	0
0	PERIPHERAL QUALIFIER			PERIPHERAL DEVICE TYPE				
1	PAGE CODE (00h)							
2	(MSB)							
3	PAGE LENGTH (n-3)						(LSB)	
4								
n	Supported VPD page list							

The supported VPD page list shall contain a list of all VPD page codes implemented by the logical unit in ascending order beginning with page code 00h.

The Mode Page Policy VPD page (see Table 11-71) indicates which mode page policy is in effect for each mode page supported by the logical unit.

**Table 5-10 — Mode Page Policy VPD page**

Bit Byte	7	6	5	4	3	2	1	0
0	PERIPHERAL QUALIFIER			PERIPHERAL DEVICE TYPE				
1	PAGE CODE (87h)							
2	(MSB)	PAGE LENGTH (n-3)						(LSB)
3								
	Mode page policy descriptor list							
4	Mode page policy descriptor [first]							
7								
	...							
n-3	Mode page policy descriptor [last]							
n								

Each mode page policy descriptor (see Table 11-72) contains information describing the mode page policy for one or more mode pages or subpages.

**Table 5-11 — Mode page policy descriptor**

Bit Byte	7	6	5	4	3	2	1	0
0	Reserved		POLICY PAGE CODE					
1	POLICY SUBPAGE CODE							
2	MLUS	Reserved					MODE PAGE POLICY = 00b	
3	Reserved							

The POLICY PAGE CODE field and POLICY SUBPAGE CODE field indicate the mode page and subpage to which the descriptor applies. See [SPC] for further details.

#### 5.5.4 Mode Page Policy VPD page (cont'd)

If more than one logical unit are configured in the device, a multiple logical units share (MLUS) bit set to one indicates the mode page and subpage identified by the POLICY PAGE CODE field and POLICY SUBPAGE CODE field is shared by more than one logical unit.

A MLUS bit set to zero indicates the logical unit maintains its own copy of the mode page and subpage identified by the POLICY PAGE CODE field and POLICY SUBPAGE CODE field.

**Table 5-12 describes the mode page policies.**

Code	Description
00b	Shared
01b	Per target port
10b	Obsolete
11b	Per I_T nexus

NOTE: This standard defines only one target port and one initiator port.

MODE PAGE POLICY field shall be set to zero (Shared).

See [SPC] for further details about Mode Page Policy VPD pag

## 6 Marking



Kingston logo

240xxxx-xxx.xxxxxx : Internal control number

YYWW : Date code (YY- Last 2 digital of year, WW- Work week)

PPPPPPPP : Internal control number

xxxxxxx-xxxx Sales P/N

xxxxxxx : Internal control number

Country : TAIWAN

## 7 Revision History

Rev.	History	Date
v1.0	Initial Release	10 / 2023

# Appendix

## UFS Descriptors

Descriptor type	Descriptor IDN
Device	00h
Configuration	00h
Unit	02h
Interconnect	04h
String	05h
Geometry	07h
Power	08h
Device Health	09h

## Device Descriptor (IDN=00h)

DEVICE DESCRIPTOR					
Offset	Size (Byte)	Name	MDV <sup>(1)</sup>	User Conf.	Description
00h	1	bLength	59h	No	Size of this descriptor
01h	1	bDescriptorIDN	00h	No	Device Descriptor Type Identifier
02h	1	bDevice	00h	No	Device Type
03h	1	bDeviceClass	00h	No	UFS Device Class
04h	1	bDeviceSubClass	00h	No	UFS Mass Storage Subclass
05h	1	bProtocol	00h	No	Protocol supported by UFS Device
06h	1	bNumberLU	03h	Yes	Number of Logical Units
07h	1	bNumberWLU	04h	No	Number of Well Known Logical Units
08h	1	bBootEnable	01h	Yes	Boot Enable Indicate whether the device is enabled for boot. 00h: Boot feature disabled 01h: Bootable feature enabled Others: Reserved

09h	1	bDescrAccessEn	01h	Yes	Descriptor Access Enable 00h: Device Descriptor access disabled 01h: Device Descriptor access enabled Others: Reserved
0Ah	1	bInitPowerMode	01h	Yes	Initial Power Mode 00h: UFS-Sleep Mode / 01h: Active Mode Others: Reserved
0Bh	1	bHighPriorityLUN	7Fh	Yes	High Priority LUN Valid values are: from 0 to the number of LU specified by bMaxNumberLU. If this parameter value is 7Fh all logical units have the same priority.
0Ch	1	bSecureRemovalType	00h	Yes	Secure Removal Type ( Also support 03h)
0Dh	1	bSecurityLU	01h	No	Support for security LU 00h: not supported 01h: RPMB Others: Reserved
0Eh	1	bBackgroundOpsTermLat	05h	No	Background Operations Termination Latency 01h(10ms)~FFh(2550ms)
0Fh	1	bInitActiveICCLevel	00h	Yes	Initial Active ICC Level Valid range from 00h to 0Fh.
10h	2	wSpecVersion	0220h	No	Specification version
12h	2	wManufactureDate	-	No	Manufacturing Date
14h	1	iManufacturerName	01h	No	Manufacturer Name
15h	1	iProductName	02h	No	ProductName
16h	1	iSerialNumber	04h	No	SerialNumber
17h	1	iOemID	03h	No	OEM ID
18h	2	wManufacturerID	0298h	No	Manufacturer ID
1Ah	1	bUD0BaseOffset	16h	No	Unit Descriptor 0 Base Offset
1Bh	1	bUDConfigPLength	1Ah	No	Unit Descr. Config. Param. Length
1Ch	1	bDeviceRTTCap	08h	No	RTT Capability of device
1Dh	2	wPeriodicRTCUpdate	0000h	Yes	Frequency and method of Real-Time Clock update.
1Fh	1	bUFSFeaturesSupport	87h	No	UFS Features Support
20h	1	bFFUTimeout	0Ah	No	Field Firmware Update Timeout (00h=no timeout)
21h	1	bQueueDepth	20h	No	Queue Depth

22h	2	wDeviceVersion	0000h	No	Device Version
24h	1	bNumSecureWPArea	20h	No	Number of Secure Write Protect Areas
25h	4	dPSAMaxDataSize	004C33FFh	No	PSA Maximum Data Size
29h	1	bPSAStateTimeout	12h	No	PSA State Timeout
2Ah	1	iProductRevisionLevel	06h	No	Product Revision Level
2Bh	5	Reserved	-	-	
30h	16	Reserved	-	-	
40h	3	Reserved	-	-	
43h	12	Reserved	-	-	
4Fh	4	dExtendedUFSFeaturesSupport	187h	No	Extended UFS Features Support bit[0]: Field Firmware Update (FFU) bit[1]: Production State Awareness (PSA) bit[2]: Device Life Span bit[3]: Refresh Operation bit[4]: TOO_HIGH_TEMPERATURE bit[5]: TOO_LOW_TEMPERATURE bit[6]: Extended Temperature bit[7]: Reserved for Host-aware Performance
53h	1	bWriteBoosterBufferPreserveUserSpaceEn	00h	Yes	
54h	1	bWriteBoosterBufferType	00h	Yes	
55h	4	dNumSharedWriteBoosterBufferAllocUnits	00h	Yes	

NOTE 1 The column "MDV" (Manufacturer Default Value) specifies parameter values after device manufacturing. Some parameters may be configured by the user writing the Configuration Descriptor.

NOTE 2 "User Conf." column specifies which fields can be configured by the user writing the Configuration Descriptor: "Yes" means that the field can be configured, "No" means that the field is a capability of the device and cannot be changed by the user. The desired value shall be set in the equivalent parameter of the Configuration Descriptor.

NOTE 3 bNumberLU field value is calculated by the device based on bLUEnable field value in the Unit Descriptors.

## Configuration Descriptor (IDN=00h)

Configuration Descriptor					
Offset	Size (Byte)	Name	MDV (1)	User Conf.	Description
00h	1	bLength	E6h	No	Size of this descriptor
01h	1	bDescriptorIDN	01h	No	Configuration Descriptor Type Identifier
02h	1	bConfDescContinue	00h	No	00h : This value indicates that this is the Configuration Descriptor in a sequence of write descriptor query requests. Device shall perform internal configuration based on received Configuration Descriptor(s).
03h	1	bBootEnable	01h	Yes	Boot Enable
04h	1	bDescrAccessEn	01h	Yes	Descriptor Access Enable
05h	1	bInitPowerMode	01h	Yes	Initial Power Mode
06h	1	bHighPriorityLUN	7Fh	Yes	High Priority LUN
07h	1	bSecureRemovalType	00h	Yes	Secure Removal Type
08h	1	bInitActiveICCLLevel	00h	Yes	Initial Active ICC Level
09h	2	wPeriodicRTCUpdate	0000h	Yes	Frequency and method of Real-Time Clock update
0Bh	5	Reserved	00h	No	Reserved for Host Performance Booster (HPB) Extension
0Ch	1	bRPMBRegionEnable	00h	Yes	RPMB Region Enable Configures which RPMB regions are enabled in RPMB well known logical unit.
0Dh	1	bRPMBRegion1Size	00h	Yes	RPMB Region 1 Size Configures the size of RPMB region 1 if RPMB region 1 is enabled.
0Eh	1	bRPMBRegion2Size	00h	Yes	RPMB Region 2 Size Configures the size of RPMB region 2 if RPMB region 2 is enabled.
0Fh	1	bRPMBRegion3Size	00h	Yes	RPMB Region 3 Size Configures the size of RPMB region 3 if RPMB region 3 is enabled.
10h	1	bWriteBoosterBufferPreserveUserSpaceEn	00h	Yes	Enable preserve user space when WriteBooster Buffer is configured.
11h	1	bWriteBoosterBufferType	00h	Yes	Configure the WriteBooster Buffer type
12h	1	dNumSharedWriteBoosterBufferAllocUnits	00h	Yes	Configure the WriteBooster Buffer size for a shared WriteBooster Buffer configuration.

NOTE 1 The column "MDV" (Manufacturer Default Value) specifies parameter values after device manufacturing.  
Some parameters may be configured by the user writing the Configuration Descriptor.

## Unit Descriptor (IDN=02h)

LUN0

Unit Descriptor configurable parameters					
Offset	Size (Byte)	Name	MDV	User Conf.	Description
00h	1	bLUEnable	01h	Yes	Logical Unit Enable
01h	1	bBootLunID	00h	Yes	Boot LUN ID
02h	1	bLUWriteProtect	00h	Yes	Logical Unit Write Protect
03h	1	bMemoryType	00h	Yes	Memory Type
04h	4	dNumAllocUnits	3B9Dh-64G	Yes	Number of Allocation Units
08h	1	bDataReliability	00h	Yes	Data Reliability
09h	1	bLogicalBlockSize	0Ch	Yes	Logical Block Size
0Ah	1	bProvisioningType	03h	Yes	Provisioning Type
0Bh	2	wContextCapabilities	00h	Yes	Context Capabilities
0Dh	3	Reserved	00h	No	
10h	6	Reserved1	00h	No	
16h	4	dLUNumWriteBoosterBufferAllocUnits	00h	Yes	The WriteBooster Buffer size for the Logical Unit.

LUN 1

Unit Descriptor configurable parameters					
Offset	Size (Byte)	Name	MDV	User Conf.	Description
00h	1	bLUEnable	01h	Yes	Logical Unit Enable
01h	1	bBootLunID	01h	Yes	Boot LUN ID
02h	1	bLUWriteProtect	00h	Yes	Logical Unit Write Protect
03h	1	bMemoryType	03h	Yes	Memory Type
04h	4	dNumAllocUnits	03h	Yes	Number of Allocation Units
08h	1	bDataReliability	00h	Yes	Data Reliability
09h	1	bLogicalBlockSize	0Ch	Yes	Logical Block Size
0Ah	1	bProvisioningType	03h	Yes	Provisioning Type
0Bh	2	wContextCapabilities	00h	Yes	Context Capabilities
0Dh	3	Reserved	00h	No	
10h	6	Reserved1	00h	No	
16h	4	dLUNumWriteBoosterBufferAllocUnits	00h	Yes	The WriteBooster Buffer size for the Logical Unit.

## LUN 2

Unit Descriptor configurable parameters					
Offset	Size (Byte)	Name	MDV	User Conf.	Description
00h	1	bLUEnable	01h	Yes	Logical Unit Enable
01h	1	bBootLunID	02h	Yes	Boot LUN ID
02h	1	bLUWriteProtect	00h	Yes	Logical Unit Write Protect
03h	1	bMemoryType	03h	Yes	Memory Type
04h	4	dNumAllocUnits	03h	Yes	Number of Allocation Units
08h	1	bDataReliability	00h	Yes	Data Reliability
09h	1	bLogicalBlockSize	0Ch	Yes	Logical Block Size
0Ah	1	bProvisioningType	03h	Yes	Provisioning Type
0Bh	2	wContextCapabilities	00h	Yes	Context Capabilities
0Dh	3	Reserved	00h	No	
10h	6	Reserved1	00h	No	
16h	4	dLUNumWriteBoosterBufferAllocUnits	00h	Yes	The WriteBooster Buffer size for the Logical Unit.

## LUN 3~LUN31

Unit Descriptor configurable parameters					
Offset	Size (Byte)	Name	MDV	User Conf.	Description
00h	1	bLUEnable	00h	Yes	Logical Unit Enable
01h	1	bBootLunID	00h	Yes	Boot LUN ID
02h	1	bLUWriteProtect	00h	Yes	Logical Unit Write Protect
03h	1	bMemoryType	00h	Yes	Memory Type
04h	4	dNumAllocUnits	00h	Yes	Number of Allocation Units
08h	1	bDataReliability	00h	Yes	Data Reliability
09h	1	bLogicalBlockSize	0Ch	Yes	Logical Block Size
0Ah	1	bProvisioningType	03h	Yes	Provisioning Type
0Bh	2	wContextCapabilities	00h	Yes	Context Capabilities
0Dh	3	Reserved	00h	No	
10h	6	Reserved1	00h	No	
16h	4	dLUNumWriteBoosterBufferAllocUnits	00h	Yes	The WriteBooster Buffer size for the Logical Unit.

## RPMB Unit

RPMB Unit Descriptor					
Offset	Size (Byte)	Name	MDV	User Conf.	Description
00h	1	bLength	23h	No	Size of this descriptor
01h	1	bDescriptorIDN	02h	No	Unit Descriptor Type Identifier
02h	1	bUnitIndex	C4h	No	Unit Index
03h	1	bLUEnable	01h	Yes	Logical Unit Enable 01h: Logical Unit enabled
04h	1	bBootLunID	00h	No	Boot LUN ID 00h: Not bootable
05h	1	bLUWriteProtect	00h	No	
06h	1	bLUQueueDepth	00h	No	
07h	1	bPSASensitive	00h	No	
08h	1	bMemoryType	0Fh	No	
09h	1	Reserved	00h	No	
0Ah	1	bLogicalBlockSize	08h	No	
0Bh	8	qLogicalBlockCount	10000h	No	
13h	4	dEraseBlockSize	00h	No	
17h	1	bProvisioningType	00h	No	
18h	8	qPhyMemResourceCount	00h	No	
20h	3	Reserved	00h		

## Interconnect Descriptor (IDN=04h)

Interconnect Descriptor				
Offset	Size	Name	Value	Description
00h	1	bLength	06h	Size of this descriptor
01h	1	bDescriptorIDN	04h	Interconnect Descriptor Type Identifier
02h	2	bcdUniproVersion	0160h	MIPI UniPro® version number in BCD format Example: version 3.21 = 0321h
04h	2	bcdMphyVersion	0300h	MIPI M-PHY® version number in BCD format Example: version 3.21=0321h

## String Descriptor (IDN=05h)

### MANUFACTURER NAME STRING DESCRIPTOR

MANUFACTURER NAME STRING				
Offset	Size	Name	Value	Description
00h	1	bLength	12h	Size of this descriptor
01h	1	bDescriptorIDN	05h	String Descriptor Type Identifier
02h-10h	16	UC[0]- UC[7]	KINGSTON	Unicode string character

### PRODUCT NAME STRING DESCRIPTOR

PRODUCT NAME STRING DESCRIPTOR				
Offset	Size	Name	Value	Description
00h	1	bLength	22h	Size of this descriptor
01h	1	bDescriptorIDN	05h	String Descriptor Type Identifier
02h-10h	16	UC[0]- UC[7]	TY7B-64G	Unicode string character

### PRODUCT REVISION LEVEL STRING DESCRIPTOR

PRODUCT REVISION LEVEL STRING DESCRIPTOR				
Offset	Size	Name	Value	Description
00h	1	bLength	0Ah	Size of this descriptor
01h	1	bDescriptorIDN	05h	String Descriptor Type Identifier
02h-08h	8	UC[0]- UC[3]	0001	Unicode string character

### OEM ID STRING DESCRIPTOR

OEM ID STRING DESCRIPTOR				
Offset	Size	Name	Value	Description
00h	1	bLength	FEh	Size of this descriptor
01h	1	bDescriptorIDN	05h	String Descriptor Type Identifier
02h-FCh	252	UC[0]- UC[125]	-	Unicode string character

## SERIAL NUMBER STRING DESCRIPTOR

SERIAL NUMBER STRING DESCRIPTOR				
Offset	Size	Name	Value	Description
00h	1	bLength	20h	Size of this descriptor
01h	1	bDescriptorIDN	05h	String Descriptor Type Identifier
02h-1Eh	30	UC[0]- UC[14]	-	Unicode string character

## Geometry Descriptor (IDN=07h)

Geometry Descriptor					
Offset	Size (Byte)	Name	MDV	User Conf.	Description
00h	1	bLength	57h	No	Size of this descriptor
01h	1	bDescriptorIDN	07h	No	Geometry Descriptor Type Identifier
02h	1	bMediaTechnology	00h	No	Reserved
03h	1	Reserved	00h	No	Reserved
04h	8	qTotalRawDeviceCapacity	07746000h	No	Total Raw Device Capacity
0Ch	1	bMaxNumberLU	01h	No	Maximum number of Logical Unit supported by the UFS device
0Dh	4	dSegmentSize	02000h	No	Segment Size
11h	1	bAllocationUnitSize	01h	No	Allocation Unit Size
12h	1	bMinAddrBlockSize	08h	No	Minimum addressable block size
13h	1	bOptimalReadBlockSize	40h	No	Optimal Read Block Size
14h	1	bOptimalWriteBlockSize	40h	No	Optimal Write Block Size
15h	1	bMaxInBufferSize	08h	No	Max. data-in buffer size
16h	1	bMaxOutBufferSize	08h	No	Max. data-out buffer size
17h	1	bRPMB_ReadWriteSize	40h	No	Maximum number of RPMB frames
18h	1	bDynamicCapacityResourcePolicy	01h	No	Dynamic Capacity Resource Policy
19h	1	bDataOrdering	00h	No	
1Ah	1	bMaxContextIDNumber	0Fh	No	

1Bh	1	bSysDataTagUnitSize	00h	No	
1Ch	1	bSysDataTagResSize	00h	No	
1Dh	1	bSupportedSecRTypes	09h	No	
1Eh	2	wSupportedMemoryTypes	807Fh	No	
20h	4	dSystemCodeMaxNAllocU	3BA3h	No	
24h	2	wSystemCodeCapAdjFac	300h	No	
26h	4	dNonPersistMaxNAllocU	3BA3h	No	
2Ah	2	wNonPersistCapAdjFac	300h	No	
2Ch	4	dEnhanced1MaxNAllocU	3BA3h	No	
30h	2	wEnhanced1CapAdjFac	300h	No	
32h	4	dEnhanced2MaxNAllocU	3BA3h	No	
36h	2	wEnhanced2CapAdjFac	300h	No	
38h	4	dEnhanced3MaxNAllocU	3BA3h	No	
3Ch	2	wEnhanced3CapAdjFac	300h	No	
3Eh	4	dEnhanced4MaxNAllocU	3BA3h	No	
42h	2	wEnhanced4CapAdjFac	300h	No	
44h	4	dOptimalLogicalBlockSize	01h	No	
48h	5	Reserved	00h	No	
4Dh	2	Reserved	00h	No	
4Fh	4	dWriteBoosterBufferMaxN AllocUnits	0800h	No	
53h	1	bDeviceMaxWriteBoosterL Us	01h	No	
54h	1	bWriteBoosterBufferCapA djFac	03h	No	
55h	1	bSupportedWriteBoosterB ufferUserSpaceReduction	01h	No	
56h	1	bSupportedWriteBoosterB ufferTypes	01h	No	

## POWER PARAMETERS DESCRIPTOR (IDN=08h)

POWER PARAMETERS DESCRIPTOR					
Offset	Size	Name	Value	User conf.	Description
00h	1	bLength	62h	No	Size of this descriptor
01h	1	bDescriptorIDN	08h	No	Power Parameters Descriptor Type Identifier
02h~20h	32	wActiveICCLevelsVCC[0]~[15]	81F4h	No	
22h~40h	32	wActiveICCLevelsVCCQ[0]~[15]	81F4h	No	
42h~60h	32	wActiveICCLevelsVCCQ2[0]~[15]	81F4h	No	

## Device Health Descriptor (IDN=09h)

Device Health Descriptor				
Offset	Size (Byte)	Name	Value	Description
00h	1	bLength	25h	Size of this descriptor
01h	1	bDescriptorIDN	09h	Device Health Descriptor Type Identifier
02h	1	bPreEOLInfo	01h	Pre End of Life Information This field provides indication about device life time
03h	1	bDeviceLifeTimeEstA	01h	This field provides an indication of the device life time based on the amount of performed program/erase cycles.
04h	1	bDeviceLifeTimeEstB	01h	This field provides an indication of the device life time based on the amount of performed program/erase cycles.
05h	32	VendorPropInfo	-	

## UFS Flags

FLAGS					
IDN	Name	Type	Type <sup>1</sup>	Default	Description
			# Ind. <sup>2</sup>		
			# Sel. <sup>3</sup>		
00h	Reserved	-	-	-	
01h	fDeviceInit	Read / Set only	D	00h	Device Initialization 0b: Device initialization completed or not started yet. 1b: Device initialization in progress.
02h	fPermanentWPEn	Read / Write once	D	00h	Permanent Write Protection Enable 00h: Permanent write protection disabled 01h: Permanent write protection enabled
03h	fPowerOnWPEn	Read / Power on reset	D	00h	Power On Write Protection Enable 0b: Power on write protection disabled. 1b: Power on write protection enabled.
04h	fBackgroundOpsEn	Read /Volatile	D	01h	Background Operations Enable 0b: Device is not permitted to run background operations. 1b: Device is permitted to run background operations.
05h	fDeviceLifeSpanModeEn	Read /Volatile	D	00h	Device Life Span Mode 0b: Device Life Span Mode is disabled. 1b: Device Life Span Mode is enabled.
06h	fPurgeEnable	Write only /Volatile	D	00h	Purge Enable 0b: Purge operation is disabled. 1b: Purge operation is enabled.

07h	Reserved	-	-	-	
08h	fPhyResourceRemoval	Read /Persistent	D	00h	Physical Resource Removal
09h	fBusyRTC	Read Only	D	00h	Busy Real Time Clock 0b : Device is not executing internal operation related to RTC 1b: Device is executing internal operation related to RTC
0Ah	Reserved	-	-	-	
0Bh	fPermanentlyDisableFwUpdate	Read /Write once	D	00h	Permanently Disable Firmware Update 0b: The UFS device firmware may be modified 1b: The UFS device shall permanently disallow future firmware updates to the UFS device
0Ch	Reserved	-	-	-	
0Dh	Reserved	-	-	-	
0Eh	fWriteBoosterEn	Read /Volatile	A/LU/0 Or D	00h	WriteBooster Enable 0b: WriteBooster is not enabled. 1b: WriteBooster is enabled.
0Fh	fWriteBoosterBufferFlushEn	Read /Volatile	A/LU/0 Or D	00h	Flush the data in WriteBooster Buffer to the user area of storage. 0b: Flush operation is not performed.
10h	fWriteBoosterBufferFlushDuringHibernate	Read /Volatile	A/LU/0 Or D	00h	Flush WriteBooster Buffer during hibernate state. 0b: Device is not allowed to flush the WriteBooster Buffer during link hibernate state. 1b: Device is allowed to flush the

NOTE 1 The type "D" identifies a device level flag, while the type "A" identifies an array of flags. If Type = "D", the flag is addressed setting INDEX = 00h and SELECTOR = 00h.

NOTE 2 For array of flags, ""# Ind." specifies the amount of valid values for the INDEX field in QUERY REQUEST/RESPONSE UPIU. If # Ind = 0, the flag is addressed setting INDEX = 00h.

NOTE 3 For array of flags, ""# Sel." specifies the amount of valid values for the SELECTOR field in QUERY REQUEST/RESPONSE UPIU. If # Sel = 0, the flag is addressed setting SELECTOR = 00h.

## UFS Attributes

ATTRIBUTES							
IDN	Name	Access Property	Size (byte)	Type <sup>1</sup>	MDV4	Description	Notes
				# Ind. <sup>2</sup>			
				# Sel. <sup>3</sup>			
00h	bBootLunEn	Read / Persistent	1	D	00h	Boot LUN Enable 00h: Boot disabled 01h: Enabled boot from Boot LU A 02h: Enabled boot from Boot LU B All others: Reserved	
01h	Reserved	-	-	-	-		
02h	bCurrentPowerMode	Read only	1	D	11h	Current Power Mode 00h: Idle power mode 10h: Pre-Active power mode 11h: Active power mode 20h: Pre-Sleep power mode 22h: UFS-Sleep power mode 30h: Pre-PowerDown power mode 33h: UFS-PowerDown power mode Others: Reserved	5
03h	bActiveICCLLevel	Read / Volatile	1	D	00h	Active ICC Level bActiveICCLLevel defines the maximum current consumption allowed during Active Mode. 00h: Lowest Active ICC level ... 0Fh: Highest Active ICC level Others: Reserved Valid range from 00h to 0Fh.	6
04h	bOutOfOrderDataEn	Read / Write once	1	D	00h	Out of Order Data transfer Enable 00h: Out-of-order data transfer is disabled. 01h: Out-of-order data transfer is enabled. Others: Reserved This bit shall have effect only when bDataOrdering = 01h	

05h	bBackgroundOpStatus	Read only	1	D	00h	<p>Background Operations Status</p> <p>Device health status for background operation</p> <p>00h: Not required</p> <p>01h: Required, not critical</p> <p>02h: Required, performance impact</p> <p>03h: Critical.</p> <p>Others: Reserved</p>	
06h	bPurgeStatus	Read only	1	D	00h	<p>Purge Operation Status</p> <p>00h: Idle (purge operation disabled)</p> <p>01h: Purge operation in progress</p> <p>02h: Purge operation stopped prematurely</p> <p>03h: Purge operation completed successfully</p> <p>04h: Purge operation failed due to logical unit queue not empty</p> <p>05h: Purge operation general failure.</p> <p>Others: Reserved.</p>	
07h	bMaxDataInSize	Read / Persistent	1	D	08h	<p>Maximum Data In Size</p> <p>Maximum data size in a DATA IN UPIU.</p> <p>Value expressed in number of 512- byte units.</p> <p>bMaxDataInSize shall not exceed the bMaxInBufferSize parameter.</p> <p>bMaxDataInSize = bMaxInBufferSize when the UFS device is shipped.</p> <p>This parameter can be written by the host only when all LU task queues are empty.</p>	7, 8
08h	bMaxDataOutSize	Read / Persistent	1	D	08h	<p>Maximum Data-Out Size</p> <p>bMaxDataOutSize = bMaxOutBufferSize when the UFS device is shipped.</p> <p>This parameter can be written by the host only when all LU task queues are empty.</p>	8

09h	dDynCapNeeded	Read only	4	A Number of LU specified by bMaxNumberLU (LUN)	0000 0000h	Dynamic Capacity Needed The amount of physical memory needed to be removed from the physical memory resources pool of the particular logical unit, in units of bOptimalWriteBlockSize.	9
0Ah	bRefClkFreq	Read / Persistent	1	D	01h	Reference Clock Frequency value 0h:19.2MHz 1h: 26MHz 2h: 38.4MHz 3h: 52MHz Others: Reserved	
0Bh	bConfigDescrLock	Read / Write once	1	D	00h	Configuration Descriptor Lock 0h: Configuration Descriptor not locked 1h: Configuration Descriptor locked Others: Reserved	
0Ch	bMaxNumOfRTT	Read / Persistent	1	D	02h	Maximum current number of outstanding RTTs in device that is allowed. bMaxNumOfRTT shall not exceed the bDeviceRTTCap parameter. This parameter can be written by the host only when all LU task queues are empty.	
0Dh	wExceptionEventControl	Read / Volatile	2	D	0000h	Exception Event Control Bit 0: DYNCAP_EVENT_EN Bit 1: SYSPPOOL_EVENT_EN Bit 2: URGENT_BKOPS_EN	
0Eh	wExceptionEventStatus	Read only	2	D	0000h	Each bit represents an exception event. Bit 0: DYNCAP_NEEDED Bit 1: SYSPPOOL_EXHAUSTED Bit 2: URGENT_BKOPS Bit 3: TOO_HIGH_TEMP Bit 4: TOO_LOW_TEMP Bit 5: WRITEBOOSTER_FLUSH_NEEDED Bit 6: PERFORMANCE_THROTTLING Bit 7 -15: Reserved	

0Fh	dSecondsPassed	Write only/Volatile	4	D	00h	Bits[31:0]: Seconds passed from TIME BASELINE (see wPeriodicRTCUpdate in Device Descriptor)	
10h	wContextConf	Read / Volatile	2	A	0000h	INDEX specifies the LU number. SELECTOR specifies the Context ID within the LU.	
				8(LUN)			
				15 (ID)			
11h	Obsolete	-	-	-	-	-	
12h	Reserved	-	-	-	-	-	
13h	Reserved	-	-	-	-	-	
14h	bDeviceFFUStatus	Read Only	1	D	00h	Device FFU Status 00h: No information 01h: Successful microcode update 02h: Microcode corruption error 03h: Internal error 04h: Microcode version mismatch 05h-FEh: Reserved 0FFh: General Error	
15h	bPSAState	Read / Persistent	1	D	00h	00h: 'Off'. PSA feature is off. 01h: 'Pre-soldering'. PSA feature is on, device is in the pre-soldering state. 02h: 'Loading Complete' PSA feature is on. The host will set to this value after the host finished writing data during pre-soldering state. 03h: 'Soldered'. PSA feature is no longer available. Set by the Device to indicate it is in post- soldering state. This attribute unchangeable after it is in 'Soldered'state.	
16h	dPSADataSize	Read / Persistent	4	D	00 ... 00h	The amount of data that the host plans to load to all logical units with bPSASensitive set to 1.	
17h	Reserved	-	-	-	-	-	
18h	Reserved	-	-	-	-	-	

19h	Reserved	-	-	-	-		
1Ah	Reserved	-	-	-	-		
1Bh	Reserved	-	-	-	-		
1Ch	bWriteBoosterBufferFlushStatus	Read only	1	A/LU/0 or D	00h	<p>Flush operation status of WriteBooster Buffer.</p> <p>00h: idle.</p> <p>Device is not flushing the WriteBooster Buffer: either the WriteBooster Buffer is empty or a flush has not been initiated</p> <p>01h: Flush operation in progress.</p> <p>The WriteBooster Buffer is not yet empty and a flush has been initiated.</p> <p>02h: Flush operation stopped prematurely. The WriteBooster Buffer is not empty and the host stopped the in-progress flush.</p> <p>03h: Flush operation completed successfully.</p> <p>04h: Flush operation general failure</p> <p>Others : Reserved</p> <p>When the bWriteBoosterBufferFlushStatus is equal to the one of values 02h, 03h or 04h, value of the bWriteBoosterBufferFlushStatus is automatically cleared as 00h right after the bWriteBoosterBufferFlushStatus is read. A write to the WriteBooster Buffer when the status is 03h will cause automatic transition to either 00h or 01h.</p>	

1Dh	bAvailableWriteBoosterBufferSize	Read only	1	A/LU/0 or D	00h	<p>Available WriteBooster Buffer Size</p> <p>This available buffer size is decreased by WriteBooster operation and increased by flush operation.</p> <p>Value expressed in unit of 10% granularity</p> <p>00h: 0% buffer remains.</p> <p>01h: 10% buffer remains.</p> <p>02h~09h: 20%~90% buffer remains</p> <p>0Ah: 100% buffer remains</p> <p>Others : Reserved</p> <p>The % reported by the attributes is remaining portion of the current WriteBooster Buffer size indicated by the dCurrentWriteBoosterBufferSize attribute.</p>	
-----	----------------------------------	-----------	---	-------------	-----	---	--

1Eh	bWriteBoosterBufferLifeTimeEst	Read only	1	A/LU/0 or D	01h	<p>This field provides an indication of the WriteBooster Buffer lifetime based on the amount of performed program/erase cycles. In cases of preserve user space configuration for WriteBooster Buffer, this lifetime will be reduced by writing on normal user level space, since WriteBooster Buffer is shared with the user level space.</p> <p>The detailed calculation method is vendor specific.</p> <p>00h: Information not available (WriteBooster Buffer is disabled)</p> <p>01h: 0% - 10% WriteBooster Buffer life time used 02h: 10% - 20% WriteBooster Buffer life time used 03h: 20% - 30% WriteBooster Buffer life time used 04h: 30% - 40% WriteBooster Buffer life time used 05h: 40% - 50% WriteBooster Buffer life time used 06h: 50% - 60% WriteBooster Buffer life time used 07h: 60% - 70% WriteBooster Buffer life time used 08h: 70% - 80% WriteBooster Buffer life time used 09h: 80% - 90% WriteBooster Buffer life time used 0Ah: 90% - 100% WriteBooster Buffer life time used 0Bh: Exceeded its maximum estimated WriteBooster Buffer life time (write commands are processed as if WriteBooster feature was disabled) Others: Reserved</p>
1Fh	dCurrentWriteBoosterBuffer	Read only	4	A/LU/0 or D	00h	The current WriteBooster Buffer size.

NOTE 1 The type “D” identifies a device level attribute, while the type “A” identifies an array of attributes. If Type = “D”, the attribute is addressed setting INDEX = 00h and SELECTOR = 00h.

NOTE 2 For array of attributes, “# Ind.” specifies the amount of valid values for the INDEX field in QUERY REQUEST/RESPONSE UPIU. If # Ind = 0, the attribute is addressed setting INDEX = 00h.

NOTE 3 For array of attributes, “# Sel.” specifies the amount of valid values for the SELECTOR field in QUERY REQUEST/RESPONSE UPIU. If # Sel

= 0, the attribute is addressed setting SELECTOR = 00h.

NOTE 4 The column “MDV” (Manufacturer Default Value) specifies attribute values after device manufacturing.

NOTE 5 bCurrentPowerMode value after device initialization may be: 20h (Pre-Sleep mode) or 22h (UFS-Sleep mode) if bInitPowerMode = 00h, or 11h (Active Mode) if bInitPowerMode = 01h.

NOTE 6 After power on or reset, bActiveICCLLevel is equal to bInitActiveICCLLevel parameter value included in the Device Descriptor. bInitActiveICCLLevel is equal to 00h after device manufacturing and it can be configured by writing the Configuration Descriptor.

NOTE 7 bMaxDataInSize = bMaxInBufferSize when the UFS device is shipped.

NOTE 8 If the host attempts to write this Attribute when there is at least one logical unit with command queue not empty, the operation shall fail, and Response field in the QUERY RESPONSE UPIU shall be set to FFh (“General failure”).

NOTE 9 dDynCapNeeded is composed by eight elements, one for each logical unit. The desired element shall be selected assigning the LUN to INDEX field of QUERY REQUEST UPIU.

## Contact Kingston



For more information, visit us at: <https://www.kingston.com/en/solutions/embedded-and-industrial>

For direct support, please contact us at: <https://www.kingston.com/en/form/embedded>

For quick questions, please email us at: [emmc@kingston.com](mailto:emmc@kingston.com)