

Features

- EIA size: 1206
- Variable capacitance
- Operating voltage: 26VDC
- High surge suppress capability
- Bidirectional and symmetrical V/I characteristics
- Multilayer ceramic construction technology
- RoHS & Halogen Free (HF) compliant
- Operating temperature range: -55°C ~ +125°C
- Storage temperature range: 5°C ~ +40°C



Applications

- Used to Help Achieve Electromagnetic Compliance of End Products
- Provides On-Board Transient Voltage Protection for ICs, CMOS and MOSFET
- Suppression of Inductive Switching or Other Transient Events Such as EFT and Surge Voltage at the Circuit Board.
- Protection of Components and Circuits Sensitive to ESD Transients Occurring on Power supplies, Control and Signal Lines.

Part Number Code

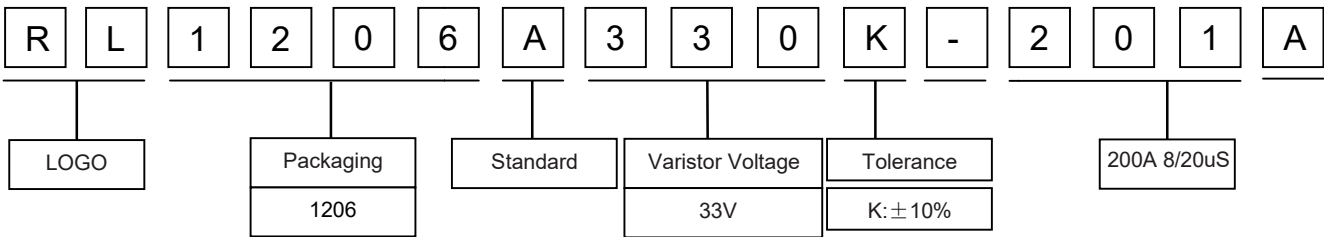

Electrical Characteristics

| Type Number | Varistor Voltage | Max. Allowable Voltage | | Max. Energy (10/1000µs) | I _L (µA) | Max. Clamping Voltage (8/20µs) | Withstanding Surge Current (8/20µs) |
|------------------|----------------------|------------------------|---------------------|-------------------------|---------------------|--------------------------------|-------------------------------------|
| | V _{1mA} (V) | V _{AC} (V) | V _{DC} (V) | (J) | | V _C (V) | I(A) |
| RL1206A330K-201A | 33(31.2~39) | 17 | 26 | 0.8 | ≤30 | 35 | 200 |

Environmental Performance

| Item | Specifications | Test Condition |
|-------------------|---------------------------|--|
| Bias Humidity | $V_V / V_V \leq \pm 10\%$ | 90%RH, 40°C, Working Voltage, 1000 hrs |
| Thermal Shock | $V_V / V_V \leq \pm 10\%$ | -40°C to 85°C, 30min.cycle, 5 cycles |
| Full Load Voltage | $V_V / V_V \leq \pm 10\%$ | Working Voltage, 85°C, 1000 hrs |

General Technical Data

| | | |
|----------------------------------|---------------------|---------------|
| Response Time | <1ns | |
| Solderability | 245±5 °C, 3±1sec | |
| Solder leach resistance | 260±5 °C, 10±1sec | |
| Taping Package Storage Condition | Storage Temperature | 5~40°C |
| | Relative Humidity | To 65% |
| | Storage Time | 12 Months max |

Soldering Parameters - Reflow Soldering (Surface Mount Devices)

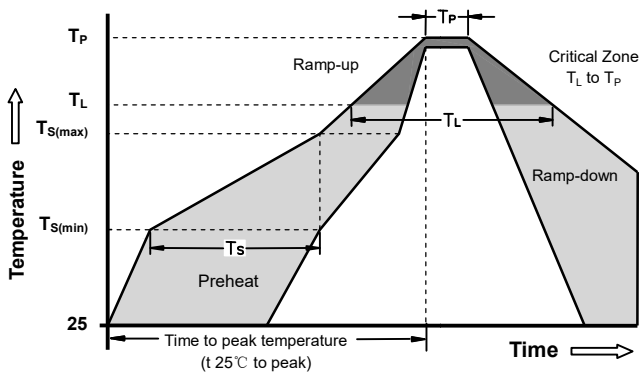

| Reflow Condition | | Pb - Free assembly |
|--|------------------------------------|--------------------|
| Pre Heat | - Temperature Min ($T_{s(min)}$) | 150°C |
| | - Temperature Max ($T_{s(max)}$) | 200°C |
| | - Time (min to max) (t_s) | 60 -180 Seconds |
| Average ramp up rate (Liquids Temp T_L) to peak | | 3°C/second max |
| $T_{s(max)}$ to T_L - Ramp-up Rate | | 3°C/second max |
| Reflow | - Temperature (T_L) (Liquids) | 217°C |
| | - Time (min to max) (t_s) | 60 -150 Seconds |
| Peak Temperature (T_P) | | 260 +0/-5°C |
| Time within 5°C of actual peak Temperature (t_p) | | 20 - 40 Seconds |
| Ramp-down Rate | | 6°C/second max |
| Time 25°C to peak Temperature (T_P) | | 8 minutes Max |
| Do not exceed | | 260°C |

Precaution for soldering

Note that this product will be easily damaged by rapid heating, rapid cooling or local heating.
Do not give heat shock over 100°C in the process of soldering. We recommend to take preheating and gradual cooling

Soldering gun procedure

Note the follows, in case of using solder gun for replacement.
1)The tip temperature must be less than 280 for the period within 3 seconds by using soldering gun under 30W
2) The soldering gun tip shall not touch this product directly.

Soldering volume

Note that excess of soldering volume will easily get crack the body of this product.

Dimensions

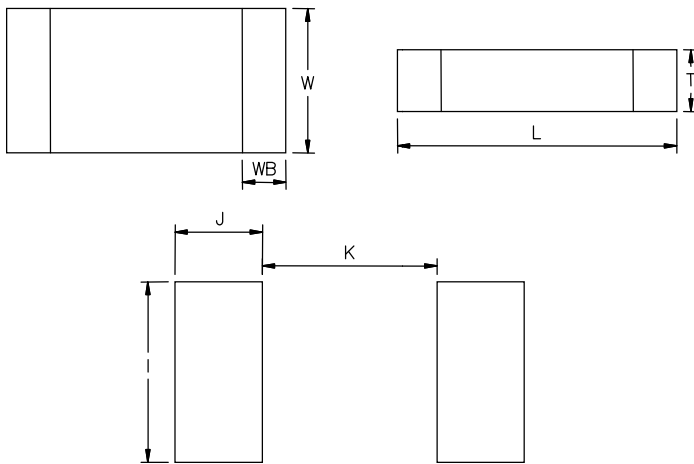

Recommended Soldering Pad Layout

| Symbol | Millimeters | Inches |
|--------|-------------|-------------|
| L | 3.20±0.3 | 0.126±0.012 |
| W | 1.60±0.3 | 0.063±0.012 |
| Tmax | 1.80 | 0.071 |
| WB | 0.5±0.20 | 0.02±0.008 |
| I | 1.5~2.0 | 0.059~0.079 |
| J | 1.2~1.8 | 0.047~0.071 |
| K | 1.8~2.5 | 0.071~0.098 |

Taping and Reel Specifications

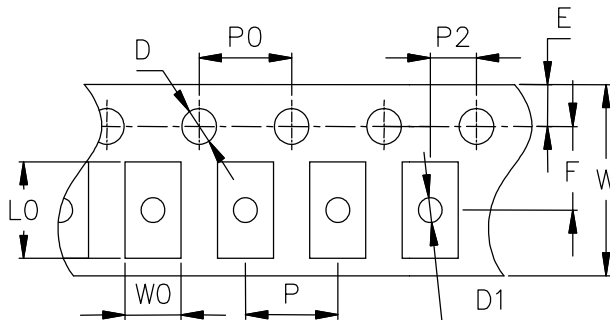

| Symbol | Millimeters | Inches |
|--------|-------------|--------------|
| W | 8.00±0.20 | 0.315±0.008 |
| E | 1.75±0.10 | 0.069±0.004 |
| F | 3.50±0.05 | 0.138±0.002 |
| D | 1.55±0.05 | 0.061±0.002 |
| D1 | Φ1.00±0.05 | Φ0.039±0.002 |
| P | 4.00±0.10 | 0.157±0.004 |
| P0 | 4.00±0.05 | 0.157±0.002 |
| P2 | 2.00±0.05 | 0.079±0.002 |
| L0 | 3.90±0.10 | 0.154±0.004 |
| W0 | 2.35±0.10 | 0.093±0.004 |

Packing Specifications

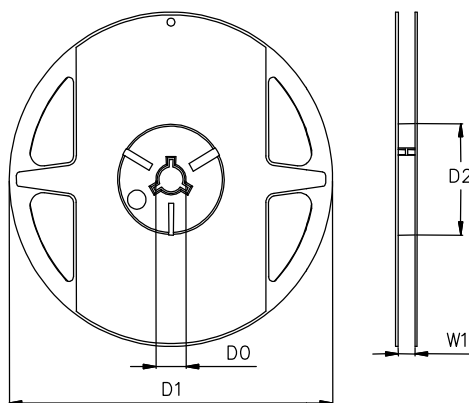

| Symbol | Millimeters | Inches |
|--------|-------------|-------------|
| D0 | 13.0±0.2 | 0.512±0.008 |
| D1 | 178±2.0 | 7.008±0.079 |
| D2 | Φ60.0±0.5 | Φ2.362±0.02 |
| W1 | 9.25±0.5 | 0.364±0.02 |

Taping Specifications

There Shall be the portion having no product in both the head and the end of taping, and there shall be the cover tape in the heat of taping.

Quantity of products in the taping package

| | |
|--------------------------------------|-----------------|
| SIZE EIA (EIAJ) | RL1206330K-201A |
| Standard Packing Quantity (PCS/reel) | 2000 |