

Features

- General Purpose, Low Cost
- Gain Bandwidth Product: 1MHz
- Low Input Bias Current: 10pA (Typ.)
- Low Offset Voltage: 5mV (Max.)
- Quiescent Current: 50μA per Amplifier (Typ.)
- Unity Gain Stable
- Rail-to-Rail Input and Output
- Single or Dual Supply Operation
- Supply Voltage Range: 2.1V to 5.5V
- Operating Temperature: -40°C ~ +125°C
- Type Package: TSSOP-8

Applications

- Temperature Sensors
- Battery-Powered Instruments
- Smoke/Gas/Environment Sensors
- Medical Equipment
- Portable Instruments and Mobile Device
- Active Filters
- Piezo Electrical Transducer Amplifier
- Sensor Interface
- Handheld Test Equipment

General Description

The LMV358 is a single supply, low power CMOS dual operational amplifier; these amplifiers offer bandwidth of 1MHz, rail-to-rail inputs and outputs, and single-supply operation from 2.1V to 5.5V. The embedded anti-RF filter can significantly increase the RF immunity without extra components. Typical low quiescent supply current of 50μA in dual operational amplifiers within one chip and very low input bias current of 10pA make the devices an ideal choice for low offset, low power consumption and high impedance applications such as smoke detectors, photodiode amplifiers, and other sensors.

Pinout (top view)

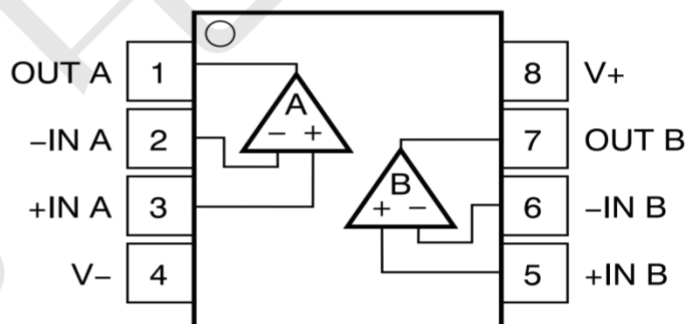

Pin Configurations

Pin Number	Pin Name	Pin Function
1	OUT A	Output A
2	-IN A	Reverse input A
3	+IN A	In-phase input A
4	-V	Chip Supply Voltage(Negative)/GND
5	+IN B	In-phase input B
6	-IN B	Reverse input B
7	OUT B	Output B
8	+V	Chip Supply Voltage(Positive)/VCC

Absolute Maximum Ratings (@TA = +25°C, unless otherwise specified.)

Condition		Rating	UNIT	
VDD to GND	Power Supply Voltage	7V	V	
IN+ or IN-	Signal Input Terminals Voltage	GND-0.3V~VDD+0.3V	V	
IN+ or IN-	Signal Input Terminals Current	-1mA ~ +1mA	mA	
OUT to GND	Output Short-Circuit	Continuous	mA	
TJ	Junction Temperature	150	°C	
LT	Lead Temperature (Soldering, 10 sec.)	260	°C	
TA	Operating Temperature Range	-50	150	°C
Tstg	Storage Temperature Range	-65	150	°C

BLOCK DIAGRAM

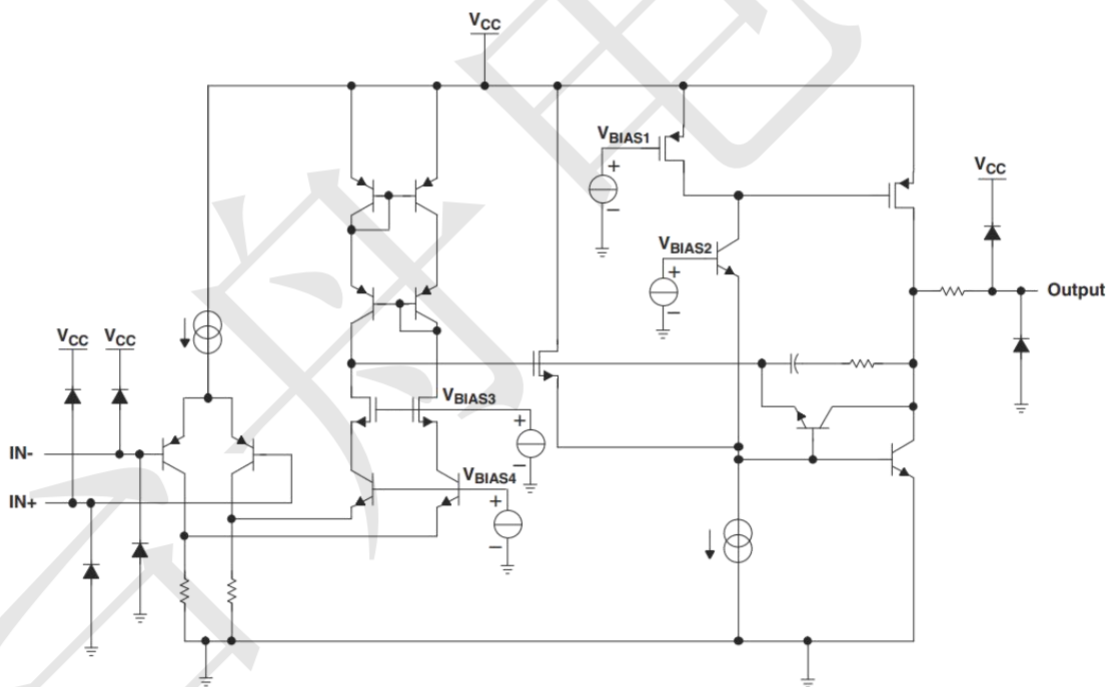

Power Supply Bypassing

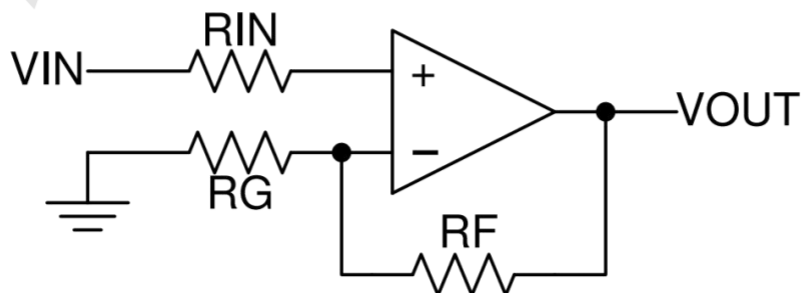

Electrical Characteristics

(At $T_A = +25^\circ\text{C}$, $V_S = +5\text{V}$, $V_{IN} = 0\text{V}$, unless otherwise noted.)

PARAMETER	SYMBOL	TEST Conditions	MIN	TYP	MAX	UNIT
Supply-Voltage Range	V_{CC}		2.1	--	5.5	V
Quiescent Current/Amplifier	I_Q	$V_{CC} = 5\text{V}$	--	50	80	μA
Input Offset Voltage	V_{OS}	$V_{CC} = \pm 2.5$	-2	0.5	5	mV
Input Offset Voltage Tempco	dV_{OS}/dT	$T_A = -55^\circ\text{C}$ to 125°C	--	0.65	--	$\mu\text{V}/^\circ\text{C}$
Input Bias Current	I_B	(2)	--	10	--	PA
Input Offset Current	I_{OS}	(2)	--	10	--	PA
Common-Mode Voltage Range	V_{CM}		GND-0.1	--	$V_{CC} + 0.1$	V
Common-Mode Rejection Ratio	CMRR	$V_{DD} + 0.1 > V_{CM} > V_{SS} - 0.1\text{V}$ $T_A = -55^\circ\text{C}$ to 125°C	80	95	--	dB
Power-Supply Rejection Ratio	PSRR	$V_{CC} = +2.5\text{V}$ to $+5.5\text{V}$ $T_A = -55^\circ\text{C}$ to 125°C	75	94	--	dB
Open-Loop Voltage Gain	A_V	$\Delta V_{OUT} = 1\text{V}$	80	100	--	dB
Output Swing from Positive Rail	$V_{OUT-SWING}$	$R_L = 5\text{k}\Omega$	--	60	--	mV
Output Swing from Negative Rail		$R_L = 100\text{k}\Omega$	--	6	--	mV
Output Short-Circuit Current	I_{SC}	Sinking or Sourcing	--	20	--	mA
Gain Bandwidth Product	GBW	$C_L = 120\text{pF}$	--	1	--	MHz
Specified temperature			-40	--	125	$^\circ\text{C}$

Notes:

- 1: All devices are 100% production tested at $T_A = +25^\circ\text{C}$; range is guaranteed by design, not production tested.
- 2: Parameter is guaranteed by design.
- 3: Capacitive load drive means that above a given maximum value, the output waveform will oscillate under the step response.

Typical Application Circuit

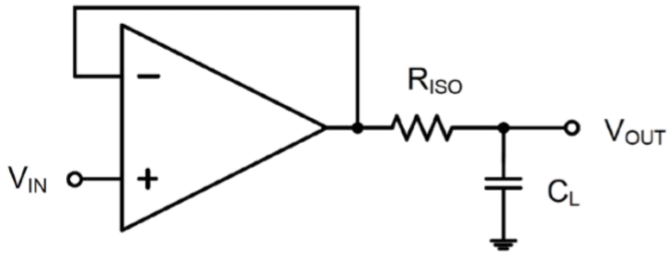

Figure 1. Indirectly Driving Heavy Capacitive Load

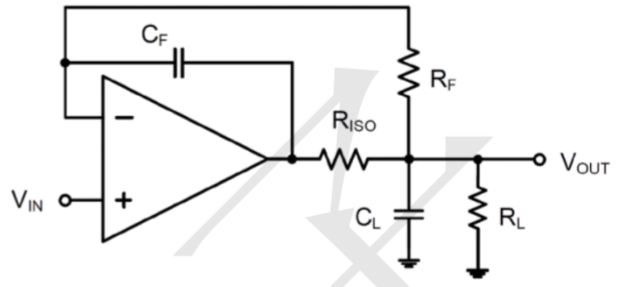

Figure 2. Indirectly Driving Heavy Capacitive Load with DC Accuracy

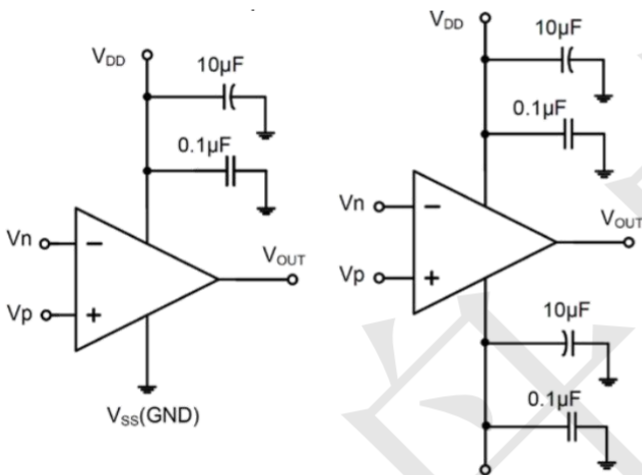

Figure 3. Amplifier with Bypass Capacitors

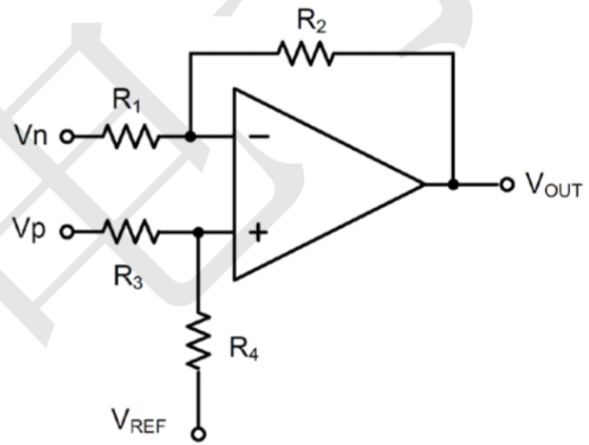

Figure 4. Differential Amplifier

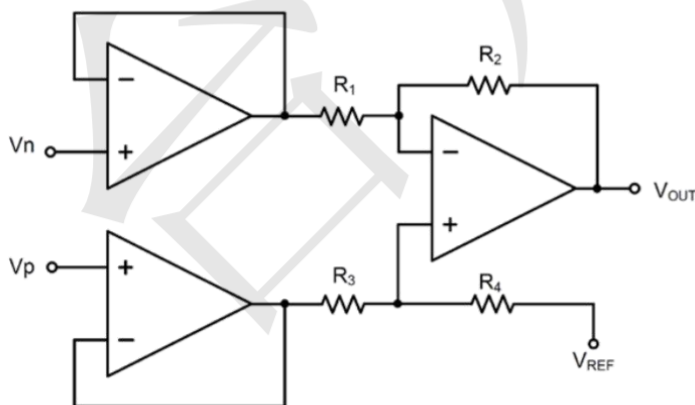

Figure 5. Instrumentation Amplifier

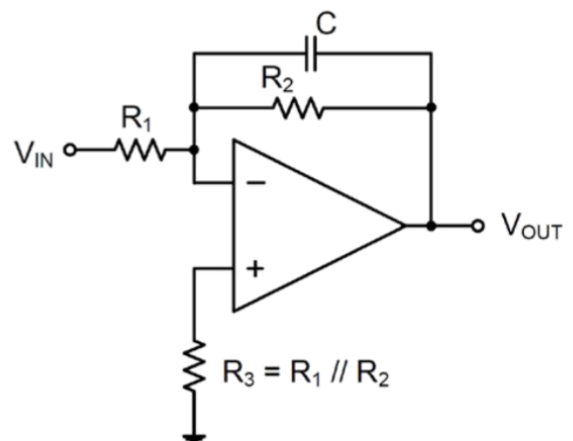
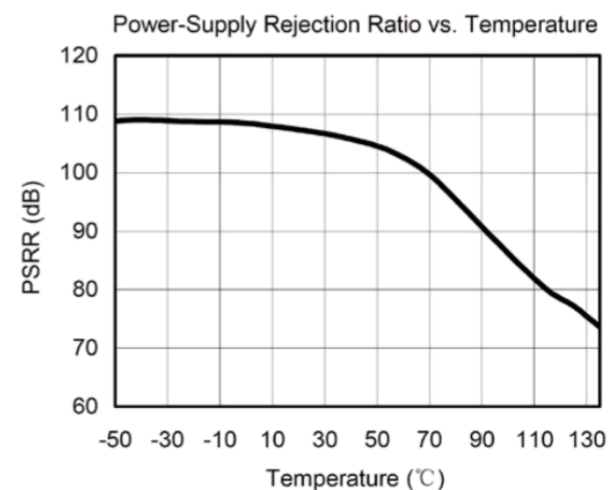
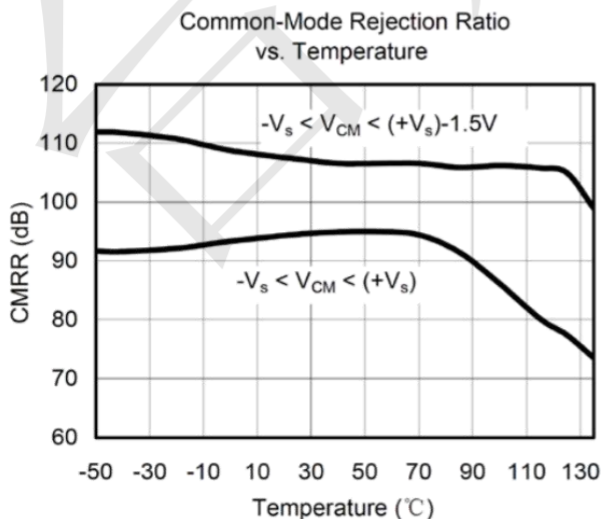
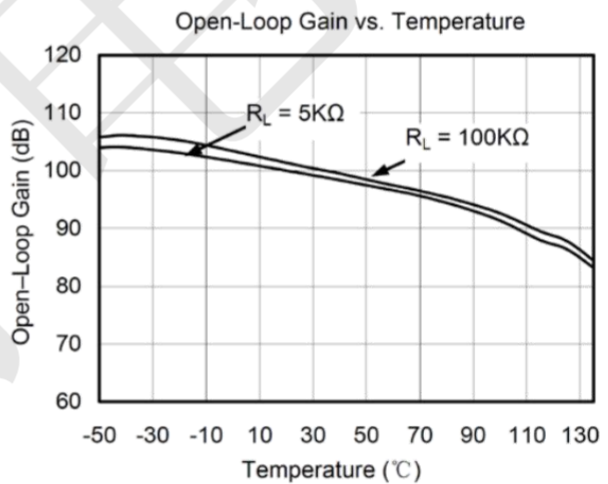
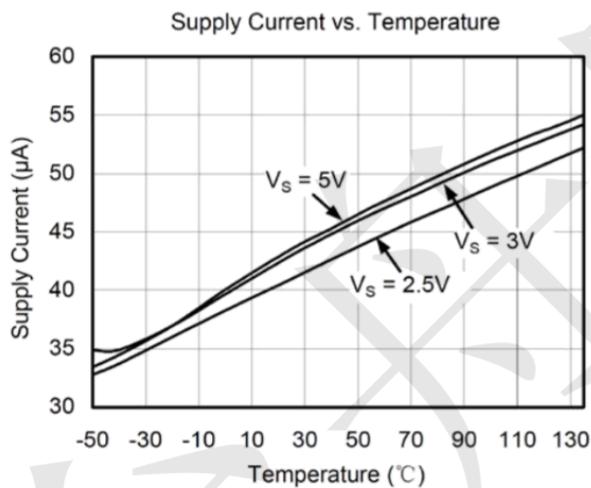
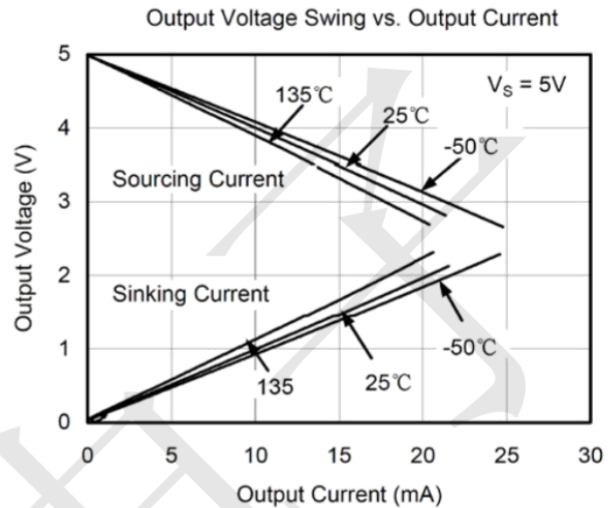
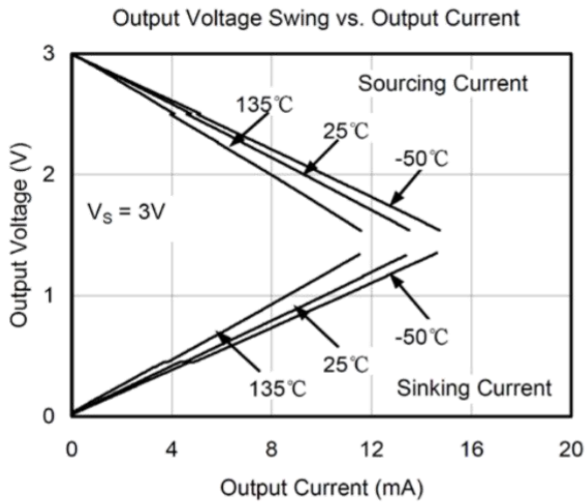

Figure 6. Low Pass Active Filter

Typical Performance Characteristics (@TA = +25°C, unless otherwise specified.)



Package information

TSSOP-8

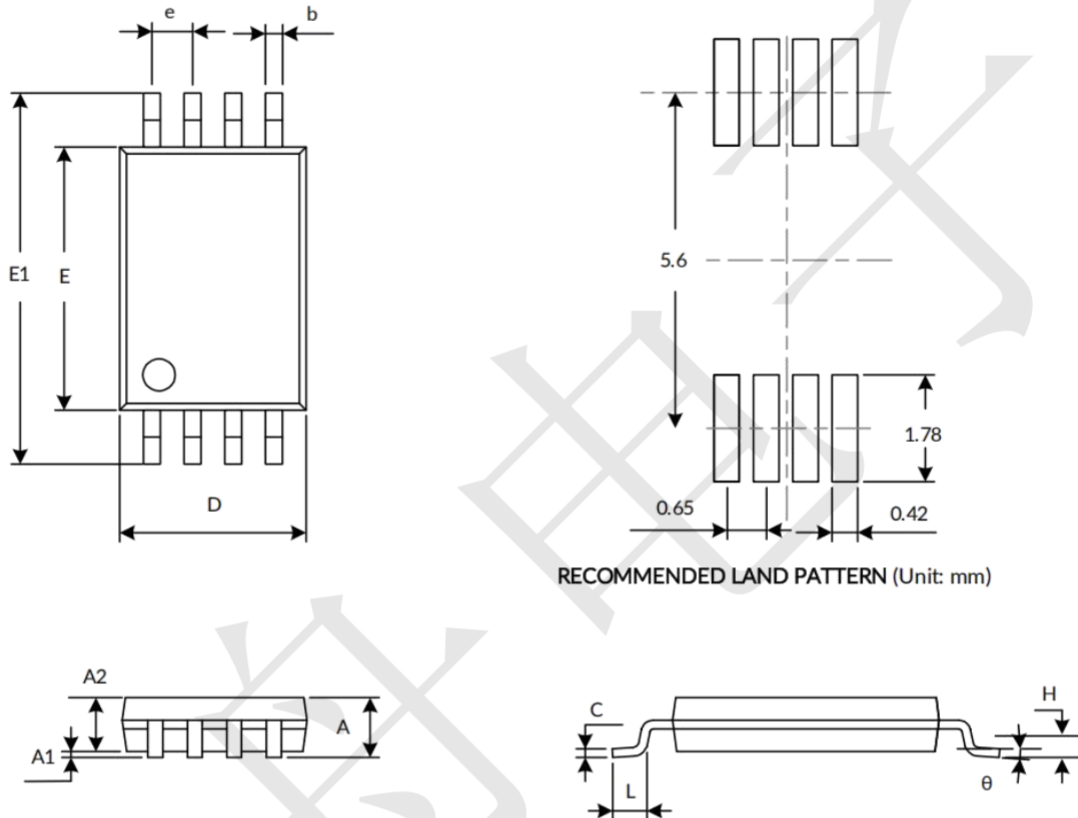

Symbol	Dimensions In Millimeters		Dimensions In Inches	
	Min	Max	Min	Max
A ⁽¹⁾		1.200		0.047
A1	0.050	0.150	0.002	0.006
A2	0.800	1.050	0.031	0.041
b	0.190	0.300	0.007	0.012
c	0.090	0.200	0.004	0.008
D ⁽¹⁾	2.900	3.100	0.114	0.122
E ⁽¹⁾	4.300	4.500	0.169	0.177
E1	6.250	6.550	0.246	0.258
e	0.650 (BSC) ⁽²⁾		0.026 (BSC) ⁽²⁾	
L	0.500	0.700	0.020	0.028
H	0.25 (TYP)		0.01 (TYP)	
θ	1°	7°	1°	7°

NOTE:

1. Plastic or metal protrusions of 0.15mm maximum per side are not included.
2. BSC (Basic Spacing between Centers), "Basic" spacing is nominal.
3. This drawing is subject to change without notice.