

P	LTR	DESCRIPTION	DATE	DWN	APVD
A		INITIAL RELEASED	08JUL2022	E.Z	E.J

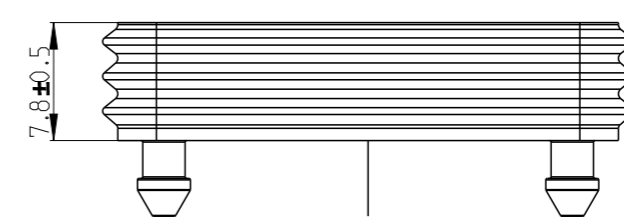
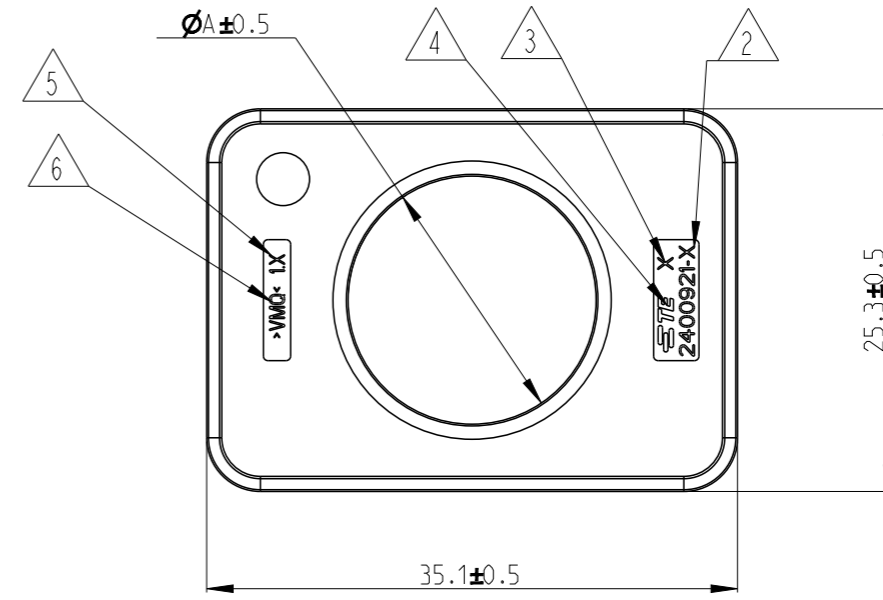
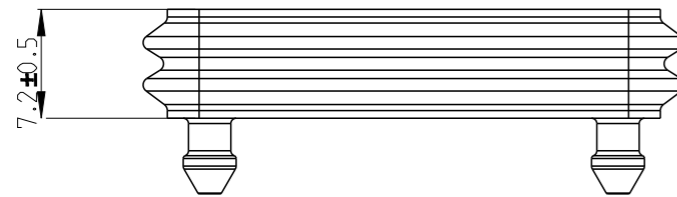
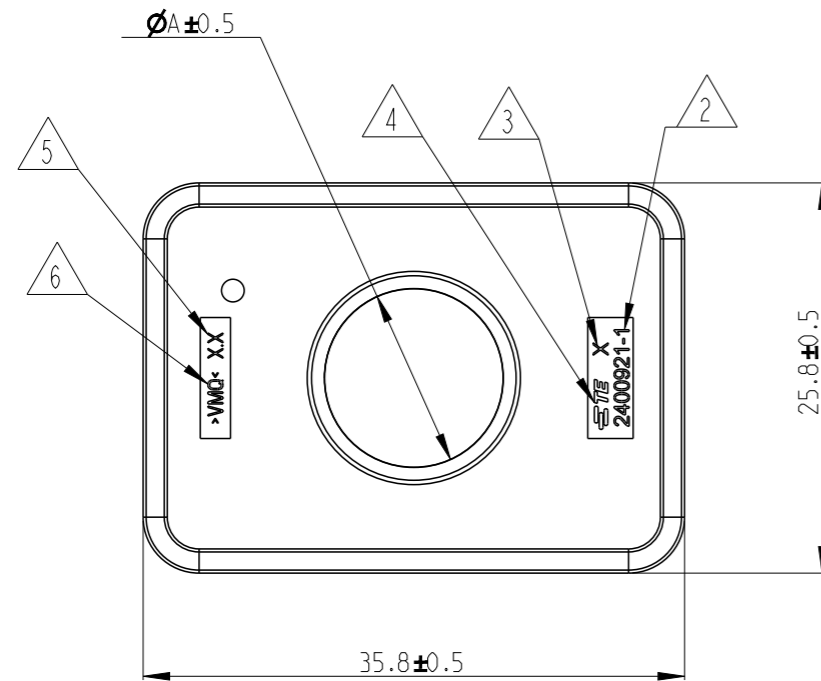

TE PART NO.	DESCRIPTION	MATERIAL	DIM. A [mm]	FOR CABLE DIAM.[mm]	WEIGHT [g]	COLOUR
2400921-2	50mm <sup>2</sup> CABLE SEAL	SILICON RUBBER	13.2	15.2...15.8	5.95	GRAY
2400921-1	35mm <sup>2</sup> CABLE SEAL	SILICON RUBBER	11.8	13.8...14.4	6	BLUE

TE PART NO.	DESCRIPTION	MATERIAL	DIM. A [mm]	FOR CABLE DIAM.[mm]	WEIGHT	COLOUR
2400921-4	25mm <sup>2</sup> CABLE SEAL	SILICON RUBBER	10.4	11.6...12.2	6.19	BROWN
2400921-3	70mm <sup>2</sup> CABLE SEAL	SILICON RUBBER	16.4	17.4...18.2	5.06	GREEN

- 1. MATERIAL : SEE TABLE
- 2. TE PART NUMBER MARKING
- 3. PART REVISION MARKING
- 4. TE LOGO MARKING
- 5. CAVITY MARKING
- 6. MATERIAL MARKING

THIS DRAWING IS A CONTROLLED DOCUMENT.		DWN E.ZHANG 08JUL2022	TE Connectivity			
DIMENSIONS: mm		CHK F.MA 08JUL2022				
		APVD E.JIANG 08JUL2022				
TOLERANCES UNLESS OTHERWISE SPECIFIED:		PRODUCT SPEC	NAME CSJ1800 90DEG PLUG 2P CABLE SEAL			
0 PLC ± 1 PLC ±0.1 2 PLC ±0.01 3 PLC ±0.001 4 PLC ±0.0001 ANGLES ± FINISH -		APPLICATION SPEC	SIZE A3	CAGE CODE 00779	DRAWING NO C=2400921	RESTRICTED TO -
MATERIAL		WEIGHT	SCALE 2:1		SHEET 1 OF 1	REV A
		CUSTOMER DRAWING				