

TS-A002

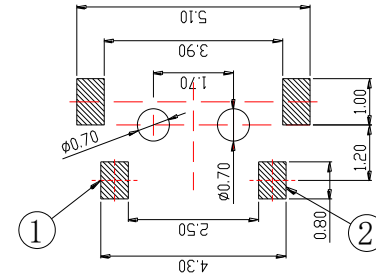

PCB. 焊接图

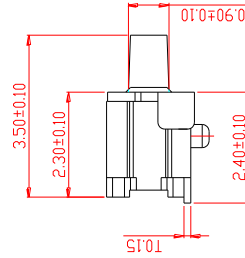
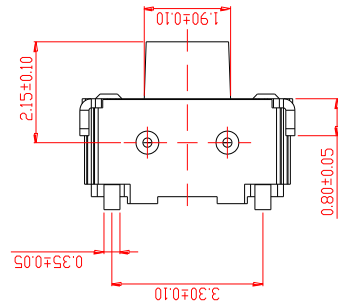
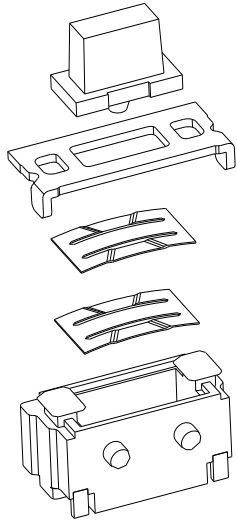
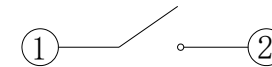
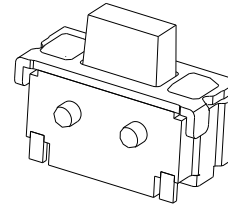
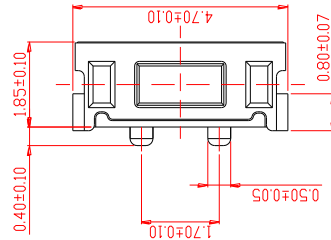

电路图

主要技术规格:

1. 额定值: 50mA DC12V
2. 接触电阻: $\leq 100\text{m}\Omega$
3. 操作力: $180 \pm 40\text{gf}$
4. 行程: $0.2 \pm 0.10\text{mm}$
5. 绝缘电阻: $\geq 100\text{M}\Omega$
6. 抗电强度: 100V 50HZ 1Min.
7. 寿命: 50,000 Cycles

材料:

- 本体: LCP (白色)
- 按钮: LCP (黑色)
- 卡件: 磷铜 (镀银)
- 弹片: 不锈钢 (镀银)
- 盖板: 磷铜 (镀银)

连兴旺电子(深圳)有限公司 LXWCONN ELECTRONICS (SHENZHEN) CO., LTD					第一视角			品名:	
								2x4x3.5侧按带柱	
标记	处数	更改文件号	签名	日期	比例	1:1	型号: LXW-TS-A002		
设计					单位	mm			
审核					重量				一般公差
批准									>0.5~2 ±0.10 >2~5 ±0.25 >5~10 ±0.30 角度 ±0.5°