

项目 Mapx	设计内容 Modification	日期 Date	修改人 Draw	核准 Approve

规格说明:Specifications:

电气特性:Electrical:

1. 额定电流: Current Rating
1.5A/contact terminal
2. 额定电压: Voltage Rating
30V DC
3. 接触电阻: Contact Resistance
30 milliohms MAX
4. 耐电压: Dielectric Withstanding Voltage:
500 V AC AT Sea Level
5. 绝缘电阻: Insulation Resistance:
1000MEGA ohms MIN

物理性能:Mechanical:

1. 插拔力: Connector Mate and Unmate Force
Mate force:3.57kgf(MAX)
Unmate force:1.02kgf(MIN)
2. 端子保持力: Terminal Retention
1.0kgf(MIN)

原材料:Material:

1. 塑胶:Housing:
Hing Temperature Ternmaplastics,
2. 端子>Contact:Copper Alloy C2680
3. 外壳:Shell: Copper Alloy C2680/SPCC

电镀:Finish:

1. 端子>Contact: Plated Gold in Mating Area,
Tin On Solder Talls
端子四周镀30-50U"(MIN)锡,镀金区域镀金1U"
2. 外壳:Shell:
铜-铁壳四周镀(MIN)镍

Nickel Plating

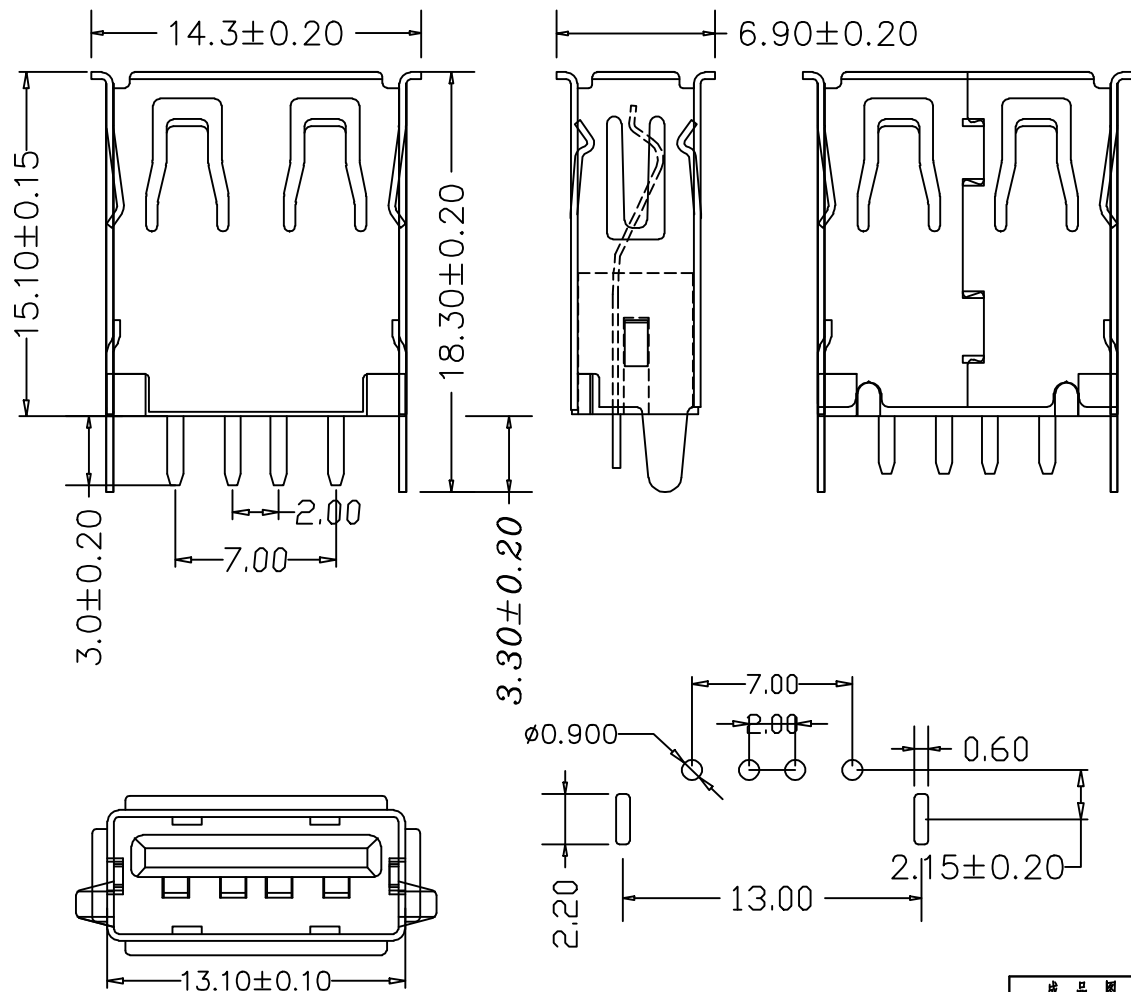

成品图 MANUFACTURE DWG		连兴旺电子(深圳)有限公司 LXWCONN ELECTRONICS (SHENZHEN) CO., LTD							
公差一览表 TOLERANCE UNLESS OTHERWISE		日期 DATE	2016.10.20	单位 UNIT	MM	制图 DRAWING	DWG NO.	TCB0005	
.X±0.15	.X±5'	日期 DATE	2016.10.20	单位 UNIT	MM	制图 DRAWING	DWG NO.	TCB0005	
XX±0.05	.X±2'	审核 CHECKED		比例 SCALE	1:1	设计 DESIGN	LIUFU	品名 NAME	15.0 卷边直脚
XXX±0.02	.XX±1'	核准 APPROVE		角法 VIEW	⊕			版本 VER	AO
								页数 SHEET	PG1