

## Features

- AEC-Q100 Qualified for Automotive Applications
  - Grade 1:  $-40^{\circ}\text{C}$  to  $125^{\circ}\text{C}$   $T_A$
- Enhanced PWM Rejection
  - Operational Voltage:  $-4\text{ V}$  to  $80\text{ V}$
  - Survival Voltage:  $-10\text{ V}$  to  $85\text{ V}$
- Wide Common-Mode Voltage
- Supply Voltage:  $3.0\text{ V}$  to  $5.5\text{ V}$
- Excellent CMRR
  - $150\text{-dB}$  DC CMRR
  - $115\text{-dB}$  AC CMRR at  $50\text{ kHz}$
- Accuracy and Zero-Drift Performance
  - $100\text{-}\mu\text{V}$  Voltage Offset (Max,  $-40^{\circ}\text{C}$  to  $125^{\circ}\text{C}$ )
  - $0.3\%$  Gain Error (Max,  $-40^{\circ}\text{C}$  to  $125^{\circ}\text{C}$ )
- Bandwidth:  $1\text{ MHz}$  (For A1, A2, A3, A4 Version)
- Excellent Start-up and Power-off Response
- Gain Options for Voltage Output
  - TPA132A1Q:  $20\text{ V/V}$
  - TPA132A2Q:  $50\text{ V/V}$
  - TPA132A3Q:  $100\text{ V/V}$
  - TPA132A4Q:  $200\text{ V/V}$
  - TPA132A5Q:  $500\text{ V/V}$

## Applications

- Motor Controls
- Current Sensing (High-Side and Low-Side)
- Solenoid and Valve Control
- Power Management

## Typical Application Circuit

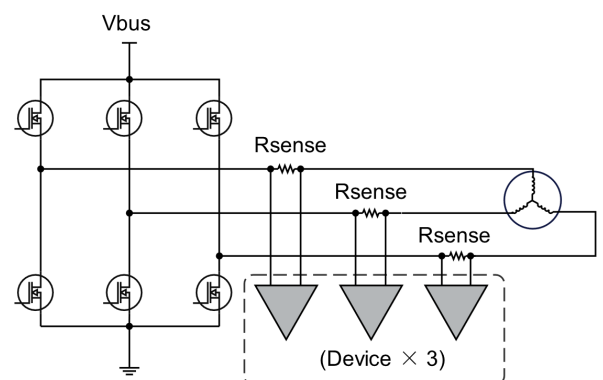

## Description

The TPA132Q is a current-sense amplifier with a very wide input common-mode voltage range from  $-4\text{ V}$  to  $80\text{ V}$  with a small-signal bandwidth of  $1\text{ MHz}$ . The enhanced PWM rejection allows the TPA132Q to accommodate the solenoids and motors applications. The device features high precision accuracy specifications of  $V_{os}$  and the gain error, which makes it ideal for the small signal conditioning interfacing with a high accuracy ADC.

Fixed gains are optional:  $20\text{ V/V}$ ,  $50\text{ V/V}$ ,  $100\text{ V/V}$ ,  $200\text{ V/V}$ , and  $500\text{ V/V}$ . The device offers breakthrough performance throughout the temperature range of  $-40^{\circ}\text{C}$  to  $+125^{\circ}\text{C}$ . The device is offered SOP8 and TSSOP8 packages.

Many systems, including motors and solenoids, employ PWM signals for modulation or control purposes. However, these PWM signals generate fast common-mode voltage transitions that oscillate between high voltage and ground potential. This can pose a challenge for the current measurement circuitry, as it may result in undesirable output voltage fluctuations. To address this issue, the device incorporates an advanced PWM rejection feature. This feature minimizes the impact of common-mode voltage transitions and ensures stable and reliable output voltage.

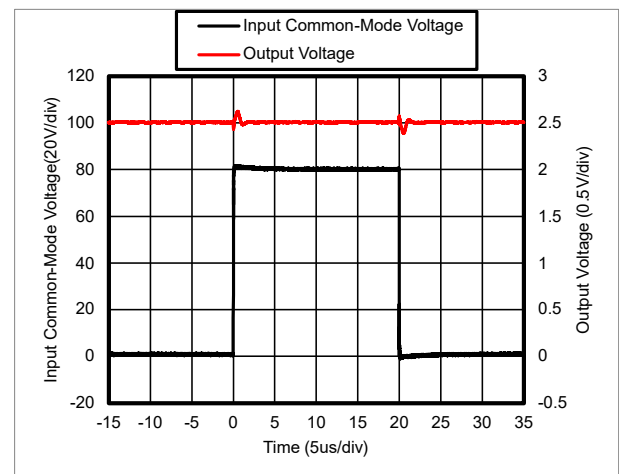

**Figure 1. Enhanced PWM Rejection Function**

## Table of Contents

<b>Features</b> .....	<b>1</b>
<b>Applications</b> .....	<b>1</b>
<b>Typical Application Circuit</b> .....	<b>1</b>
<b>Description</b> .....	<b>1</b>
<b>Revision History</b> .....	<b>3</b>
<b>Pin Configuration and Functions</b> .....	<b>4</b>
<b>Specifications</b> .....	<b>5</b>
Absolute Maximum Ratings <sup>(1)</sup> .....	5
ESD, Electrostatic Discharge Protection.....	5
Thermal Information.....	5
Electrical Characteristics.....	6
Typical Performance Characteristics.....	9
<b>Detailed Description</b> .....	<b>12</b>
Overview.....	12
Feature Description.....	12
<b>Application and Implementation</b> .....	<b>14</b>
Application Information .....	14
<b>Layout</b> .....	<b>16</b>
Layout Guideline.....	16
Layout Example.....	16
<b>Tape and Reel Information</b> .....	<b>17</b>
<b>Package Outline Dimensions</b> .....	<b>19</b>
SOP8.....	19
TSSOP8.....	20
<b>Order Information</b> .....	<b>21</b>
<b>IMPORTANT NOTICE AND DISCLAIMER</b> .....	<b>22</b>

## Revision History

Date	Revision	Notes
2024-08-30	Rev.A.0	Initial version.
2025-11-27	Rev.A.1	<ol style="list-style-type: none"><li>1. Added new orderable part number "TPA132A2Q-SO1R-S", "TPA132A3Q-SO1R-S", "TPA132A1Q-TS1R-S" and "TPA132A3Q-TS1R-S".</li><li>2. The following updates are all about the new datasheet formats or typos, and the actual product remains unchanged.<ul style="list-style-type: none"><li>• Updated figures of Gain vs. Frequency and CMRR vs. Frequency.</li></ul></li></ol>

## Pin Configuration and Functions

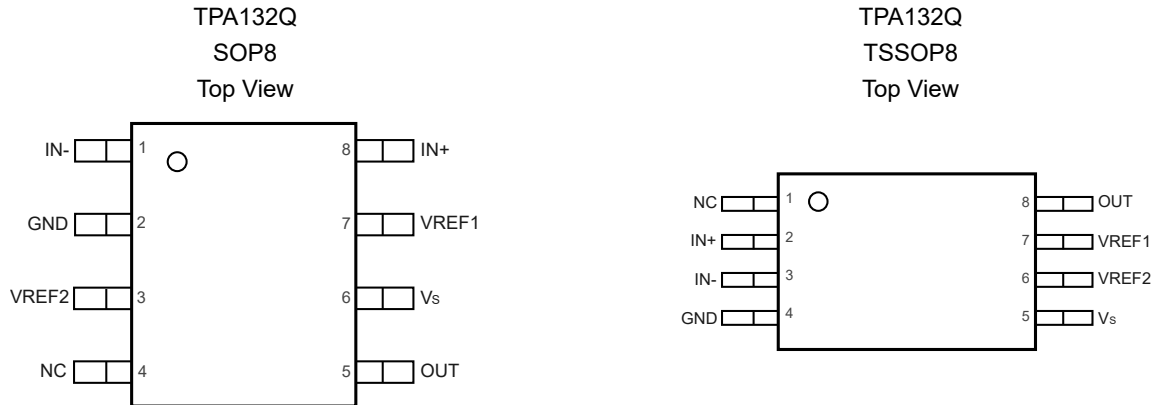

**Table 1. Pin Functions: TPA132Q**

Pin No.		Name	I/O	Description
SOP8	TSSOP8			
1	3	IN-	I	Inverting input.
2	4	GND		Ground.
3	6	VREF2	I	Reference 2 voltage, 0 V to $V_s$ .
4	1	NC		Not connected.
5	8	OUT	O	Output voltage.
6	5	$V_s$		Power supply, 3 V to 5.5 V.
7	7	VREF1	I	Reference 1 voltage, 0 V to $V_s$ .
8	2	IN+	I	Noninverting input.

**Automotive Current-Sense Amplifier with PWM Rejection**
**Specifications**
**Absolute Maximum Ratings <sup>(1)</sup>**

Parameter		Min	Max	Unit
	Supply Voltage		6	V
	Input Common Voltage	-15	90	V
	Input Differential Voltage, (IN+) - (IN-)		10	V
	Input Current: +IN, -IN	-10	+10	mA
T <sub>J</sub>	Maximum Operating Junction Temperature		150	°C
T <sub>A</sub>	Operating Temperature Range	-40	125	°C
T <sub>STG</sub>	Storage Temperature Range	-65	150	°C
T <sub>L</sub>	Lead Temperature (Soldering, 10 sec)		260	°C

(1) Stresses beyond those listed under Absolute Maximum Ratings may cause permanent damage to the device. Exposure to any Absolute Maximum Rating condition for extended periods may affect device reliability and lifetime.

**ESD, Electrostatic Discharge Protection**

Symbol	Parameter	Condition	Minimum Level	Unit
HBM	Human Body Model ESD	AEC Q100-002	2	kV
CDM	Charged Device Model ESD	AEC Q100-011	1.5	kV

**Thermal Information**

Package Type	$\theta_{JA}$	$\theta_{JC}$	Unit
SOP8	158	43	°C/W
TSSOP8	191	44	°C/W

**Automotive Current-Sense Amplifier with PWM Rejection**
**Electrical Characteristics**

All test conditions:  $V_S = 3\text{ V}$ ,  $T_A = 25^\circ\text{C}$ ,  $V_{\text{SENSE}} = (IN+) - (IN-)$ ,  $V_{\text{CM}} = (IN+) = 80\text{ V}$ ,  $V_{\text{REF1}} = V_{\text{REF2}} = V_S / 2$ , unless otherwise noted.

Symbol	Parameter	Conditions	Min	Typ	Max	Unit
<b>Input</b>						
$V_{\text{OS}}$	Input Offset Voltage	$V_{\text{SENSE}} = 0\text{ mV}$ , $T_A = -40^\circ\text{C}$ to $125^\circ\text{C}$		$\pm 20$	$\pm 100$	$\mu\text{V}$
$V_{\text{OS TC}}$	Input Offset Voltage Drift	$V_{\text{SENSE}} = 0\text{ mV}$ , $T_A = -40^\circ\text{C}$ to $125^\circ\text{C}$		0.15	0.5	$\mu\text{V}/^\circ\text{C}$
$V_{\text{CM}}^{(1)}$	Specified Common-Mode Input Range	$V_{\text{SENSE}} = 0\text{ mV}$ , $T_A = -40^\circ\text{C}$ to $125^\circ\text{C}$	-4		80	V
	Survival Common-Mode Input Range	$V_{\text{SENSE}} = 0\text{ mV}$ , $T_A = -40^\circ\text{C}$ to $125^\circ\text{C}$	-10		85	V
$\text{CMRR}^{(2)}$	Common-Mode Rejection Ratio	$-4\text{ V} < V_{\text{CM}} < 80\text{ V}$ , $T_A = -40^\circ\text{C}$ to $125^\circ\text{C}$	130	150		dB
$I_{\text{B}}$	Input Bias Current	$V_{\text{SENSE}} = 0\text{ mV}$		1	50	$\mu\text{A}$
$I_{\text{OS}}$	Input Offset Current	$V_{\text{SENSE}} = 0\text{ mV}$		0.1	1	$\mu\text{A}$
<b>Noise RTI</b>						
$e_{\text{n}}$	Input Voltage Noise Density	$f = 1\text{ kHz}$		80		$\text{nV}/\sqrt{\text{Hz}}$
<b>Output</b>						
G	Gain	TPA132A1Q		20		V/V
		TPA132A2Q		50		V/V
		TPA132A3Q		100		V/V
		TPA132A4Q		200		V/V
		TPA132A5Q		500		V/V
GE	Gain Error	TPA132A1Q, TPA132A2Q, TPA132A3Q, TPA132A4Q		$\pm 0.05$	$\pm 0.2$	%
		$T_A = -40^\circ\text{C}$ to $125^\circ\text{C}$ TPA132A1Q, TPA132A2Q, TPA132A3Q, TPA132A4Q			$\pm 0.3$	%
		TPA132A5Q		$\pm 0.1$	$\pm 0.3$	%
		$T_A = -40^\circ\text{C}$ to $125^\circ\text{C}$ TPA132A5Q			$\pm 0.5$	%
	Non-Linearity Error <sup>(2)</sup>	$\text{GND} + 10\text{mV} \leq V_{\text{OUT}} \leq V_S - 200\text{ mV}$ , $T_A = -40^\circ\text{C}$ to $125^\circ\text{C}$		$\pm 0.01$		%
$\text{GE TC}^{(2)}$	Gain Error vs. Temperature	$T_A = -40^\circ\text{C}$ to $125^\circ\text{C}$ TPA132A1Q, TPA132A2Q, TPA132A3Q		1.5	10	$\text{ppm}/^\circ\text{C}$
		$T_A = -40^\circ\text{C}$ to $125^\circ\text{C}$ TPA132A4Q, TPA132A5Q		1.5	12	$\text{ppm}/^\circ\text{C}$
$C_{\text{LOAD}}$	Maxim Capacitive Load	No Oscillation		1		nF

**Automotive Current-Sense Amplifier with PWM Rejection**

Symbol	Parameter	Conditions	Min	Typ	Max	Unit
V <sub>OH</sub>	Output Swing from V <sub>S</sub>	V <sub>S</sub> = 5.5 V, R <sub>L</sub> = 10 kΩ to GND		8	25	mV
		V <sub>S</sub> = 5.5 V, R <sub>L</sub> = 10 kΩ to GND, T <sub>A</sub> = -40°C to 125°C			30	mV
V <sub>OL</sub>	Output Swing from GND	V <sub>S</sub> = 5.5 V, R <sub>L</sub> = 10 kΩ to GND, V <sub>SENSE</sub> = 0 mV, V <sub>REF1</sub> = V <sub>REF2</sub> = 0 V		3	15	mV
		V <sub>S</sub> = 5.5 V, R <sub>L</sub> = 10 kΩ to GND, V <sub>SENSE</sub> = 0 mV, V <sub>REF1</sub> = V <sub>REF2</sub> = 0 V, T <sub>A</sub> = -40°C to 125°C			20	mV
<b>Reference Input</b>						
	Reference Input Range		0		V <sub>S</sub>	V
RVRR	Reference Voltage Rejection Ratio	V <sub>S</sub> = 5.5 V, V <sub>REF1</sub> = V <sub>REF2</sub> = 0.5 V to (V <sub>S</sub> - 0.5 V) TPA132A1Q		6		μV/V
		V <sub>S</sub> = 5.5 V, V <sub>REF1</sub> = V <sub>REF2</sub> = 0.5 V to (V <sub>S</sub> - 0.5 V) TPA132A2Q, TPA132A3Q		3		μV/V
		V <sub>S</sub> = 5.5 V, V <sub>REF1</sub> = V <sub>REF2</sub> = 0.5 V to (V <sub>S</sub> - 0.5 V) TPA132A4Q		2		μV/V
		V <sub>S</sub> = 5.5 V, V <sub>REF1</sub> = V <sub>REF2</sub> = 0.5 V to (V <sub>S</sub> - 0.5 V) TPA132A5Q		1		μV/V
RDA	Reference Divide Accuracy	V <sub>S</sub> = 5.5 V, V <sub>CM</sub> = 80 V, V <sub>SENSE</sub> = 0 mV, V <sub>OUT1</sub> : V <sub>REF1</sub> = GND, V <sub>REF2</sub> = V <sub>S</sub> , V <sub>OUT2</sub> : V <sub>REF1</sub> = V <sub>S</sub> , V <sub>REF2</sub> = GND, R <sub>DA</sub> = (V <sub>OUT1</sub> - V <sub>OUT2</sub> ) / (V <sub>OUT1</sub> / 2 + V <sub>OUT2</sub> / 2), T <sub>A</sub> = -40°C to 125°C TPA132A1Q, TPA132A2Q		±0.01	±0.12	%
		V <sub>S</sub> = 5.5 V, V <sub>CM</sub> = 80 V, V <sub>SENSE</sub> = 0 mV, V <sub>OUT1</sub> : V <sub>REF1</sub> = GND, V <sub>REF2</sub> = V <sub>S</sub> , V <sub>OUT2</sub> : V <sub>REF1</sub> = V <sub>S</sub> , V <sub>REF2</sub> = GND, R <sub>DA</sub> = (V <sub>OUT1</sub> - V <sub>OUT2</sub> ) / (V <sub>OUT1</sub> / 2 + V <sub>OUT2</sub> / 2), T <sub>A</sub> = -40°C to 125°C TPA132A5Q		±0.02	±0.25	%
<b>Frequency Response</b>						
BW	Bandwidth	TPA132A1Q, TPA132A2Q, TPA132A3Q, TPA132A4Q		1		MHz
		TPA132A5Q		0.5		MHz
SR	Slew Rate	TPA132A1Q, TPA132A2Q, TPA132A3Q, TPA132A4Q		11.5		V/μs
		TPA132A5Q		8.5		V/μs
<b>Power Supply</b>						

**Automotive Current-Sense Amplifier with PWM Rejection**

Symbol	Parameter	Conditions	Min	Typ	Max	Unit
$V_S$	Supply Voltage	$T_A = -40^{\circ}\text{C}$ to $125^{\circ}\text{C}$	3.0		5.5	V
$I_Q$	Quiescent Current	$V_S = 3.0\text{ V}$		2.5	3	mA
		$V_S = 3.0\text{ V}$ , $T_A = -40^{\circ}\text{C}$ to $125^{\circ}\text{C}$			3.1	mA
		$V_S = 5.5\text{ V}$		2.9	3.7	mA
		$V_S = 5.5\text{ V}$ , $T_A = -40^{\circ}\text{C}$ to $125^{\circ}\text{C}$			4	mA
PSRR	Power Supply Rejection Ratio	$3.0\text{ V} < V_S < 5.5\text{ V}$ , $T_A = -40^{\circ}\text{C}$ to $125^{\circ}\text{C}$	80	90		dB

- (1) To keep the device safe, the common-mode voltage at both  $V_{IN+}$  and  $V_{IN-}$  must not exceed the survival common-mode input range. To guarantee the specification, common-mode voltage at both  $V_{IN+}$  and  $V_{IN-}$  should be within the specification common-mode input range.
- (2) Provided by bench test and design simulation.

# Automotive Current-Sense Amplifier with PWM Rejection

## Typical Performance Characteristics

All test conditions:  $V_S = 3\text{ V}$ ,  $T_A = 25^\circ\text{C}$ ,  $V_{\text{SENSE}} = (IN+) - (IN-)$ ,  $V_{\text{CM}} = (IN+) = 80\text{ V}$ ,  $V_{\text{REF1}} = V_{\text{REF2}} = V_S / 2$ , unless otherwise noted.

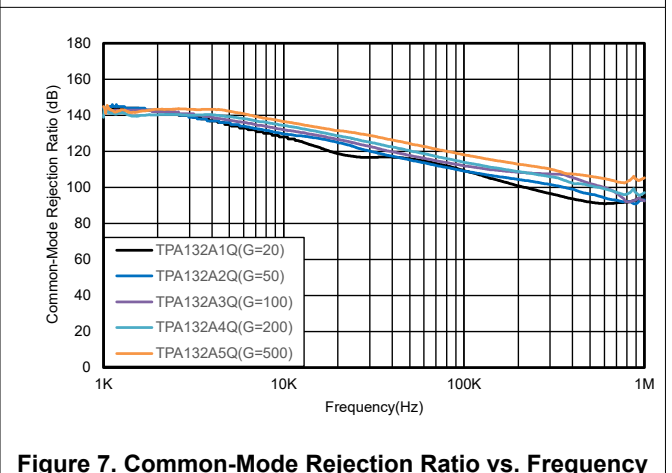
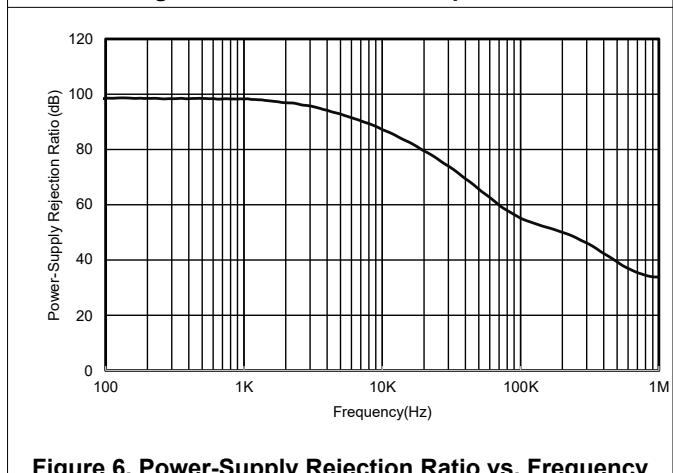
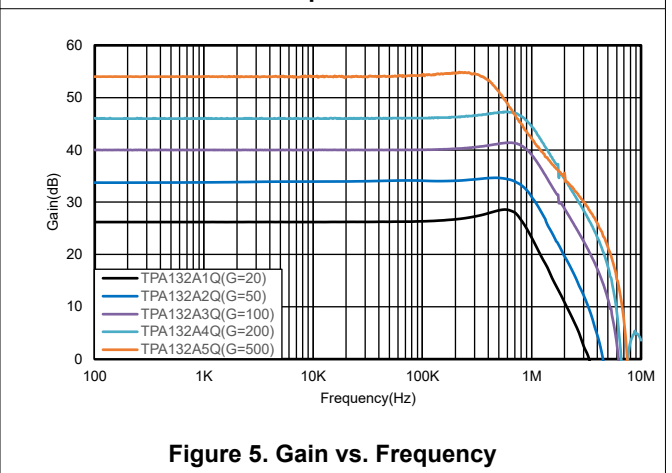
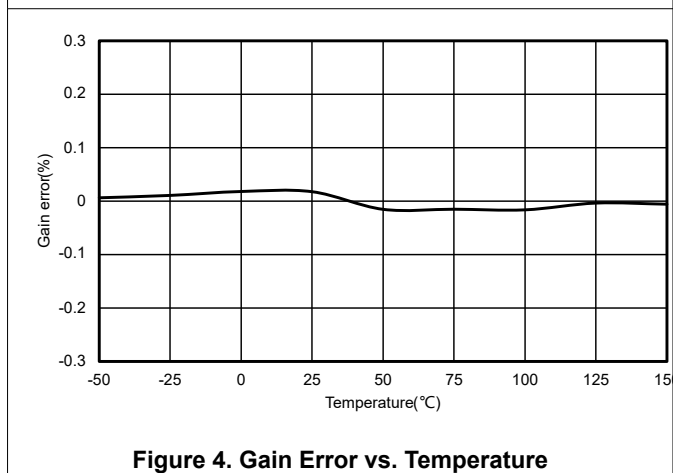
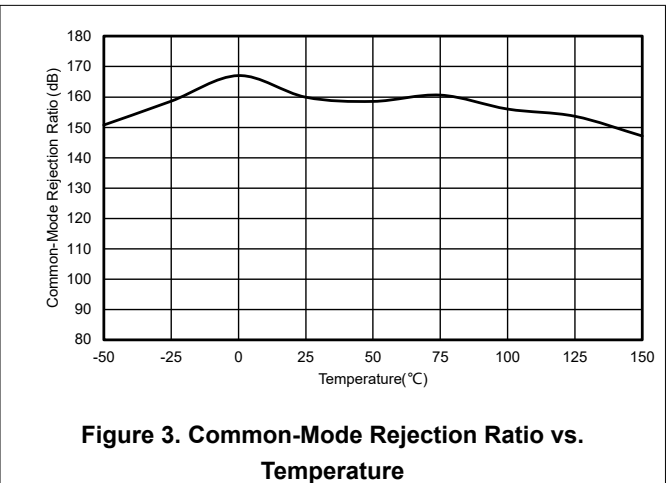
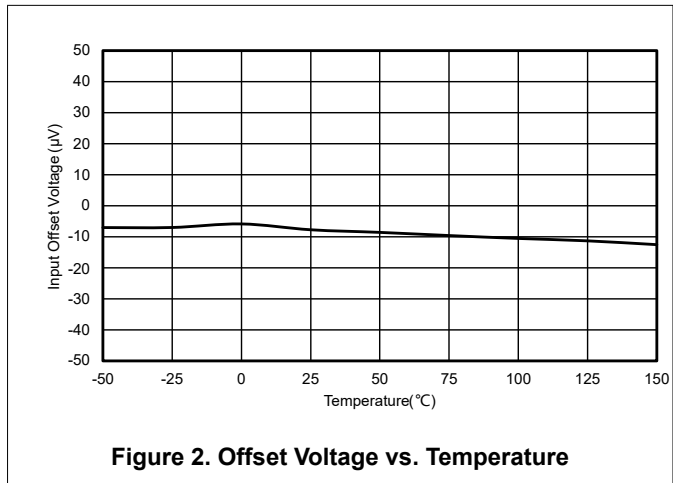

Automotive Current-Sense Amplifier with PWM Rejection

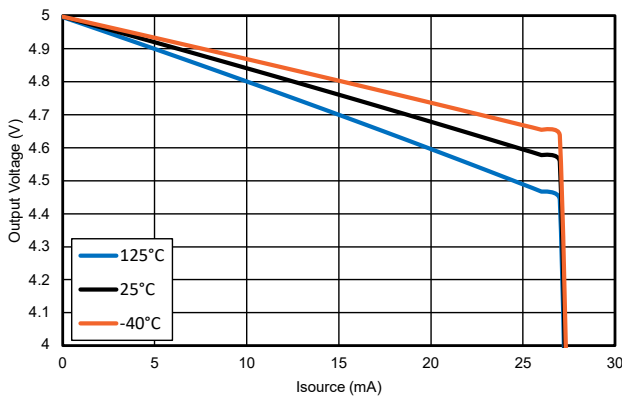

Figure 8. Output Voltage Swing vs.  $I_{SOURCE}$

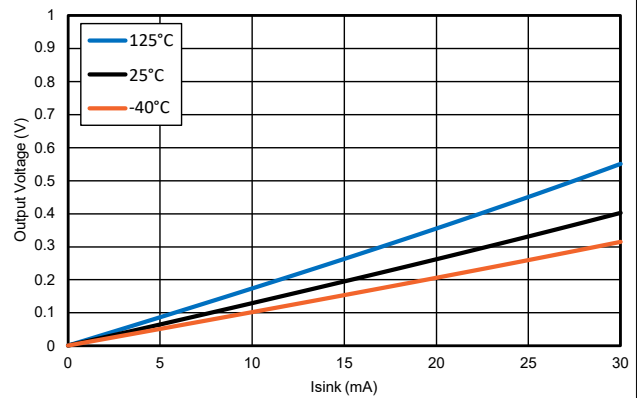

Figure 9. Output Voltage Swing vs.  $I_{SINK}$

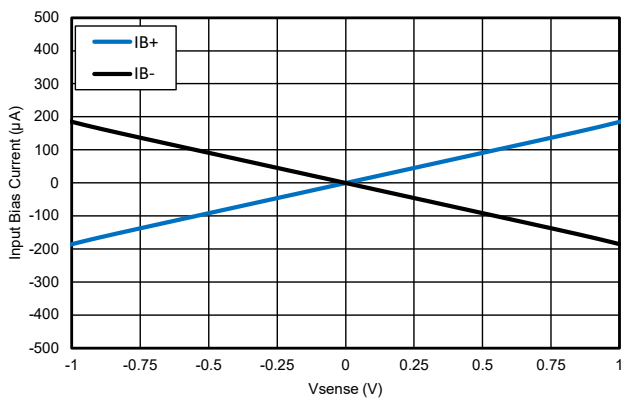

Figure 10. Input Bias Current vs.  $V_{SENSE}$

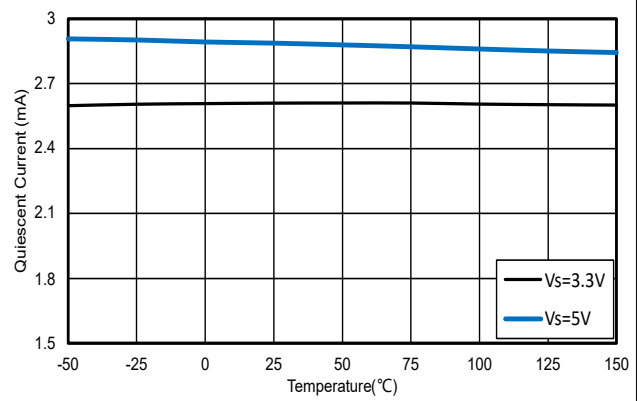

Figure 11. Quiescent Current vs. Temperature

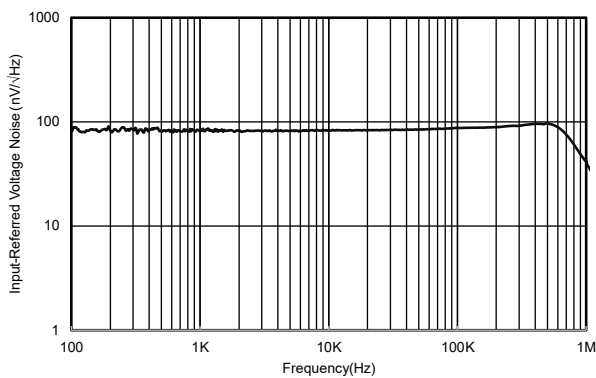

Figure 12. Input-Referred Voltage Noise vs. Frequency

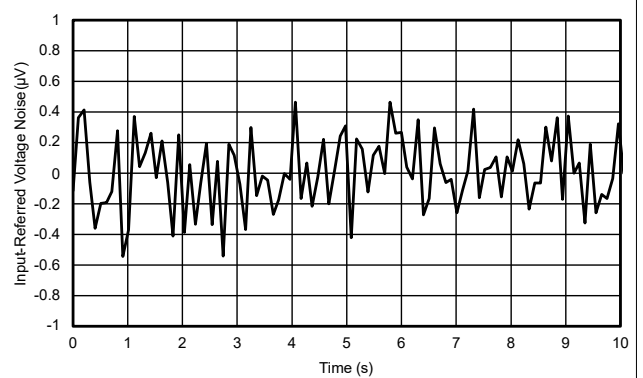

Figure 13. 0.1-Hz to 10-Hz Voltage Noise

Automotive Current-Sense Amplifier with PWM Rejection

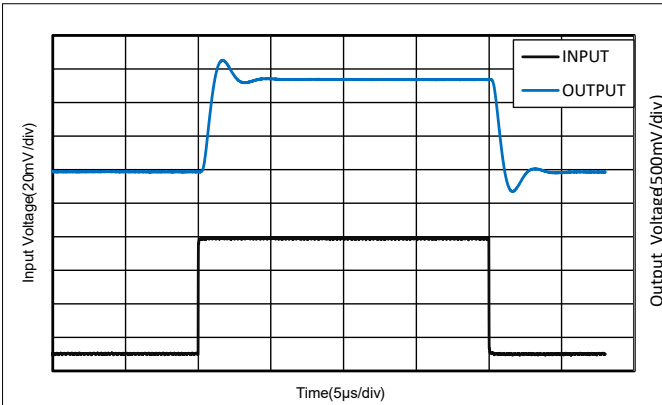
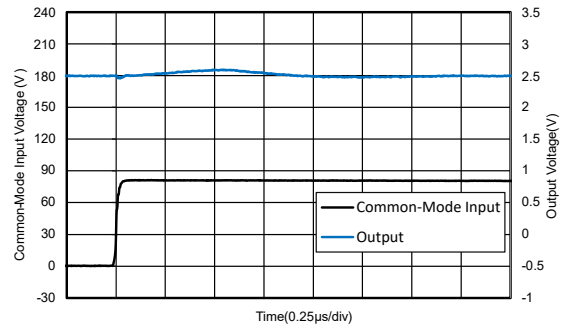
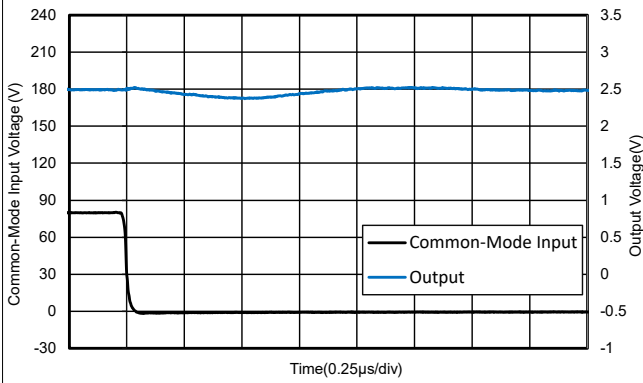

Figure 14. Step Response



$V_{CM} = 0\text{ V to }80\text{ V}$ ,  $T_{rise} = 30\text{ ns}$ ,  $V_{REF1} = V_{REF2} = 2.5\text{ V}$

Figure 15. Common-Mode Voltage Transient Response



$V_{CM} = 80\text{ V to }0\text{ V}$ ,  $T_{fall} = 30\text{ ns}$ ,  $V_{REF1} = V_{REF2} = 2.5\text{ V}$

Figure 16. Common-Mode Voltage Transient Response

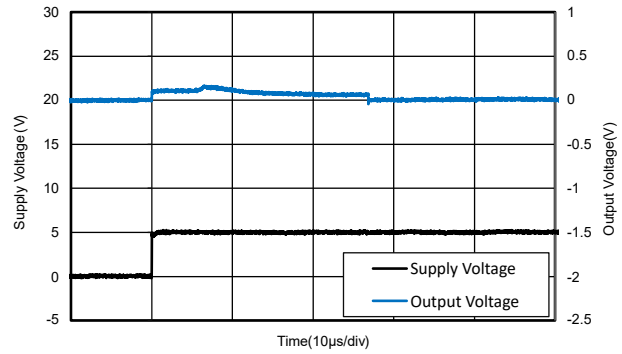

$V_{CC} = 0\text{ V to }5\text{ V}$ ,  $T_{rise} = 30\text{ ns}$ ,  $V_{CM} = 80\text{ V}$ ,  $V_{REF1} = V_{REF2} = 0\text{ V}$

Figure 17. Start-Up Response

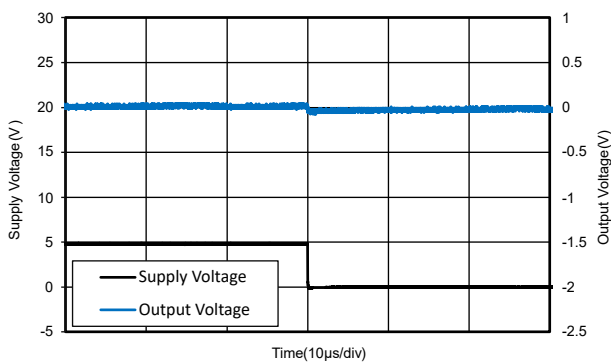

$V_{CC} = 5\text{ V to }0\text{ V}$ ,  $T_{fall} = 30\text{ ns}$ ,  $V_{CM} = 80\text{ V}$ ,  $V_{REF1} = V_{REF2} = 0\text{ V}$

Figure 18. Power-Off Response

## Detailed Description

### Overview

The TPA132Q is a high-precision current-sense amplifier with excellent CMRR. Because of its wide input common-mode voltage range, it can be both used in the high-side and low-side current sensing. The TPA132Q features enhanced PWM rejection, and it maintains an excellent performance even when the input common mode has fast  $\Delta V/\Delta t$  transitions. The TPA132Q has a bandwidth of up to 1 MHz and an SR of 11.5 V/us, which makes it suitable for overcurrent protection and loop control systems that require a fast response speed. The TPA132Q boasts exceptional performance in both start-up and power-off scenarios. Its meticulously designed output control mechanisms effectively prevent the system from triggering false alarms and ensure stability and reliability.

### Feature Description

#### Wide Input Common-Mode Voltage Range and Enhanced PWM Rejection

The TPA132Q supports a  $-4\text{V}$  to  $80\text{V}$  input common-mode voltage that is independent of the supply voltage ( $V_S$ ). The ability to operate with common-mode voltages greater or less than  $V_S$  allows the TPA132Q to be used in both high-side and low-side current-sensing applications.

For a typical solenoid application as shown in [Figure 19](#), when the switch is closed, the common-mode voltage across the  $R_{sense}$  swings to the battery voltage (e.g. 48 V). When the switch is open, the common-mode voltage across the  $R_{sense}$  reverses to one diode drop below ground (e.g.  $-0.7\text{V}$ ) due to the recirculation. It brings fast common-mode voltage transitions to the amplifier. The TPA132Q provides excellent CMRR and enhances the PWM rejection of this application.

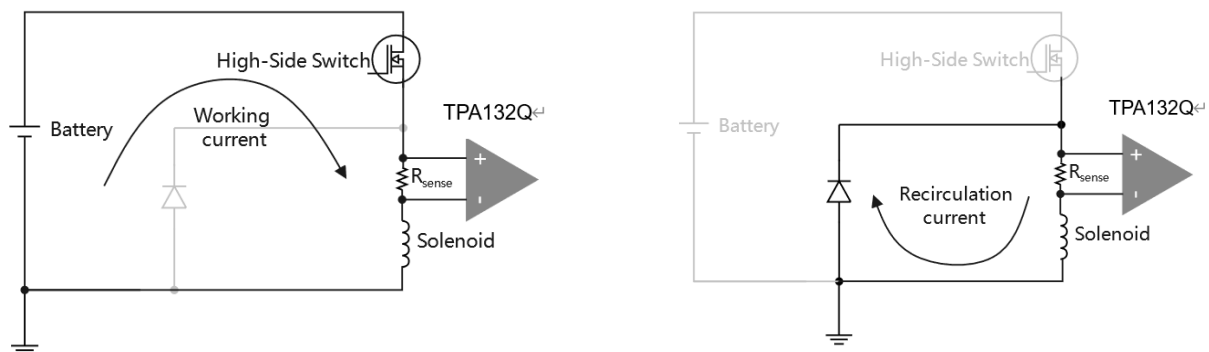

**Figure 19. Solenoid Application Circuits**

#### Reference Input, REF

The TPA132Q has two reference inputs which range from GND to  $V_S$ . It can be used both in unidirectional and bidirectional current sensing operations. The output can be calculated by [Equation 1](#).

$$V_{OUT} = V_{SENSE} \cdot \text{Gain} + \frac{V_{REF1} + V_{REF2}}{2} \quad (1)$$

#### For Unidirectional Current Sensing

It is a cost-effective solution to connect both REF1 and REF2 to GND or  $V_S$ . However, the current measurement close to 0 is incorrect considering  $V_{OL}/V_{OH}$ .

## Automotive Current-Sense Amplifier with PWM Rejection

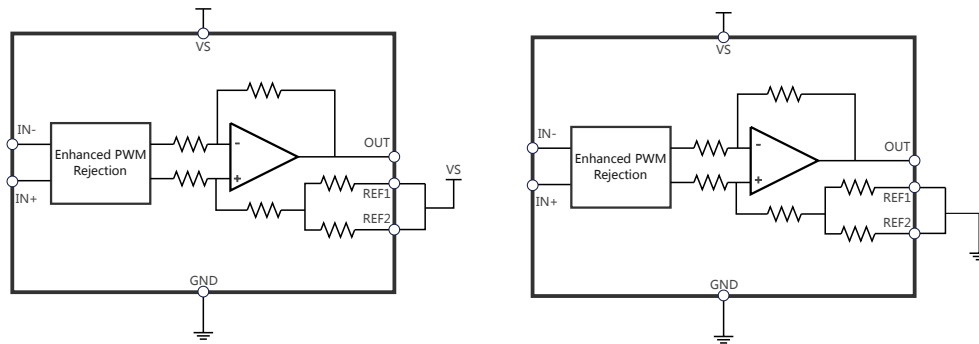

Figure 20. Unidirectional Application Schematic

### For Bidirectional Current Sensing

Connecting REF1 to  $V_S$  and REF2 to GND is a convenient way to make the output voltage remain  $V_S/2$  where there is 0 input. But the output voltage introduces the  $V_S$  noise. Connecting REF1 and REF2 to the external reference is a precision but expensive way.

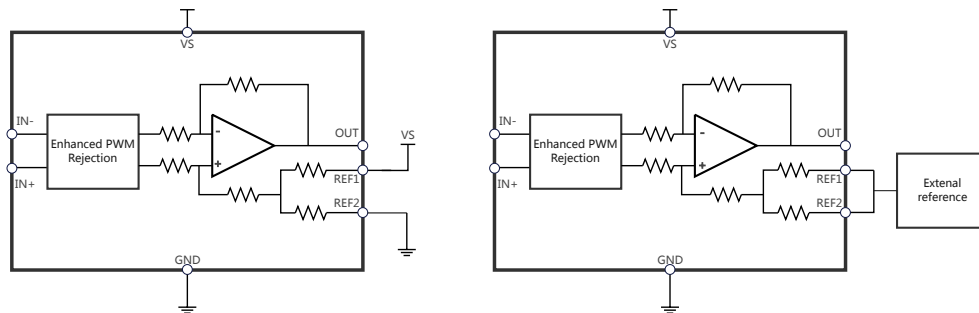

Figure 21. Bidirectional Application Schematic

### Excellent start-up and power-off response

If there is no special treatment, the output of the current-sense amplifier may generate glitches up to the supply voltage during the start-up or power-off of the device. This may cause the system to mistakenly believe that an overcurrent has occurred, leading to fault protection. Using this type of device makes the system more complex and unreliable.

The output of the TPA132Q is carefully controlled during its start-up and power-off process to prevent the false triggering of the overcurrent protection, leading to increased reliability and stability. The TPA132Q ensures that the output false pulse remains below 700 mV in all scenarios, including:

**Various  $V_{CM}$  and  $V_{SENSE}$ :**  $V_{CM}$  (common-mode voltage) and  $V_{SENSE}$  ( $(V_{IN+}) - (V_{IN-})$ ) are set to any voltage allowed in the Electrical Characteristics table (e.g.  $V_{CM} = 80$  V,  $V_{SENSE} = 50$  mV), depending on the application requirements. This enables stable operations regardless of whether the bus voltage in the system is present or not.

**Various  $V_{REF}$ :** Same as  $V_{CM}$  and  $V_{SENSE}$ ,  $V_{REF}$  (reference voltage) are set to any voltage allowed in the Electrical Characteristics Tables (e.g.  $V_{REF} = 0$  V or 2.5 V), allowing for flexibility in adjusting the sensitivity of the current sensor detection circuit.

**Various  $V_{CC}$  ramp-up and ramp-down rates:**  $V_{CC}$  (supply voltage) is ramped-up or ramped-down at different rates ranging from nanoseconds to milliseconds. This makes the TPA132Q suitable for complex industrial scenarios.

## Application and Implementation

### Note

Information in the following application sections is not part of the 3PEAK's component specification and 3PEAK does not warrant its accuracy or completeness. 3PEAK's customers are responsible for determining suitability of components for their purposes. Customers should validate and test their design implementation to confirm system functionality.

## Application Information

### Selecting the Sense Resistor

The careful selection of an appropriate sense resistor is paramount in achieving accurate and reliable current measurements. To ensure the best performance, it is recommended to carefully evaluate the trade-offs between the resistance value, accuracy, power dissipation, and temperature coefficient.

When selecting a sense resistor, two primary factors should be considered: the desired current measurement range and accuracy, as well as the power dissipation in the resistor. The resistance value and tolerance must be chosen in accordance with the desired current measurement range and the required level of accuracy. Optimizing system performance often involves considering the input voltage across the sense resistor throughout its full dynamic range. However, it is crucial to note that higher resistance values contribute to increased power dissipation, potentially leading to resistor overheating. Moreover, the resistance value may also exhibit drift due to the influence of the temperature coefficient.

### Input Filter

The input signal of the TPA132Q is sampled by the capacitor with a frequency of about 8 MHz, as shown in [Figure 22](#).

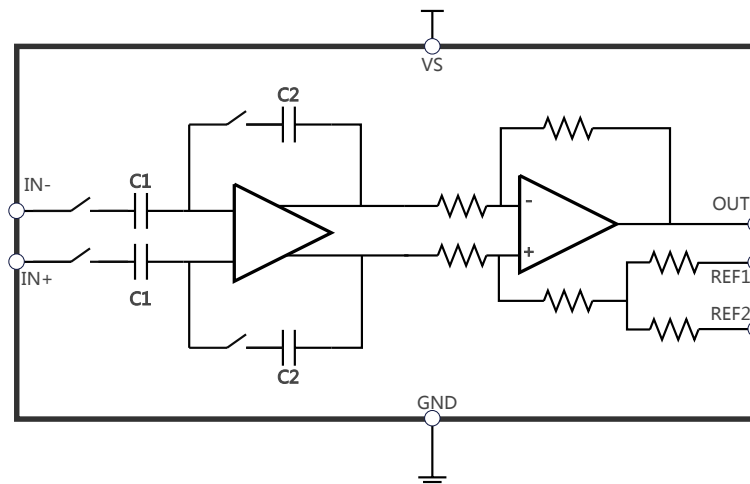
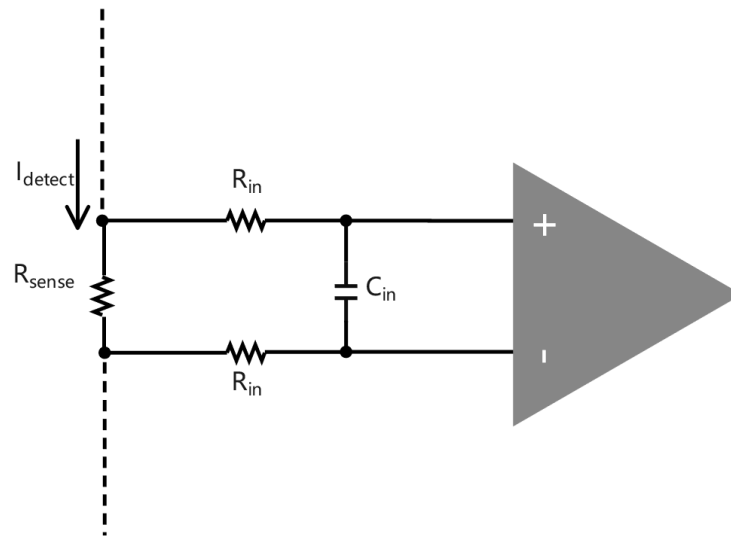

**Figure 22. Brief Circuit Diagram of TPA132Q**

According to the Nyquist Sampling Theorem, under-sampling may lead to aliasing. When the noise with a frequency greater than  $1/2 * F_{CLK}$  (4 MHz) is present, it may be aliased to lower frequencies by the sampling structure, interfering with the effective signal.

Therefore, it is highly recommended to include an anti-alias filter at the input of the TPA132Q. A common first-order RC low-pass filter is shown in [Figure 23](#).

## Automotive Current-Sense Amplifier with PWM Rejection

**Figure 23. Input Filter Circuit**

The bandwidth of the system with filtering can be calculated using [Equation 2](#):

$$BW_{\text{Filter}} = \frac{1}{2\pi (2 \cdot R_{in}) C_{in}} \quad (2)$$

However, it is crucial to be aware of the potential side effects of input filtering. The input resistance  $R_{in}$  plays a role in the voltage division with the chip's differential impedance  $R_{diff}$  (5.6 k $\Omega$   $\pm$ 15% for the TPA132Q), which can introduce an additional gain error:

$$\text{Gain Error} = \frac{2 R_{in}}{2 R_{in} + R_{diff}} \quad (3)$$

In general, we have the following suggestions for the input of the TPA132Q:

1. Add an anti-alias low-pass filter with a cutoff frequency equal to or less than the bandwidth of the TPA132Q (1 MHz).
2. To reduce the gain error, it is recommended that  $R_{in}$  is less than or equal to 10  $\Omega$  if the system is not calibrated.

## Layout

### Layout Guideline

- When working with high currents through the  $R_{SENSE}$  resistor, it's crucial to minimize the errors caused by the solder and parasitic trace resistance. The four-terminal current sense resistor or the Kelvin (force and sense) PCB layout is recommended to ensure accurate current sensing and optimal performance of the TPA132Q.
- Ensure that the sense resistor has an ample copper trace area to effectively dissipate heat. This minimizes temperature-induced changes in the value of the resistor and maintains the measurement accuracy.
- Place a 0.1- $\mu\text{F}$  bypass capacitor as close as possible to the supply and ground pins of the TPA132Q. This minimizes the impact of noise and impedance on the power supply and ensures stable operation.
- Place a low-pass filter as close as possible to the input pins of the TPA132Q. This effectively avoids aliasing and improves measurement accuracy.

### Layout Example

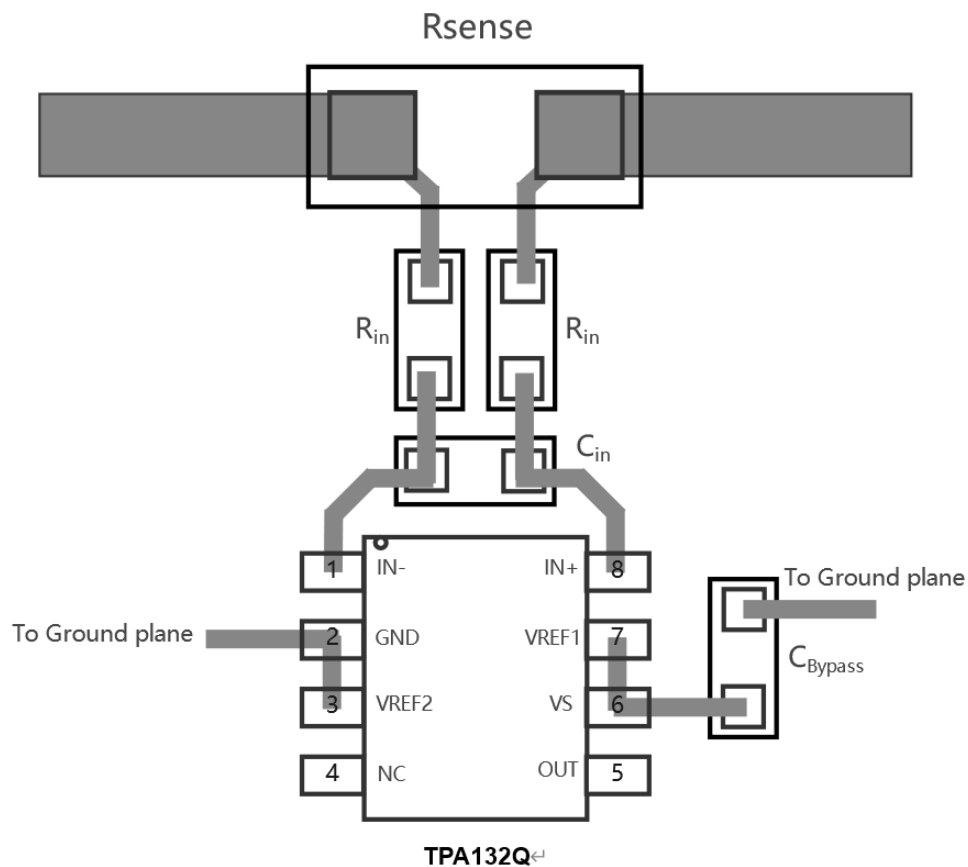
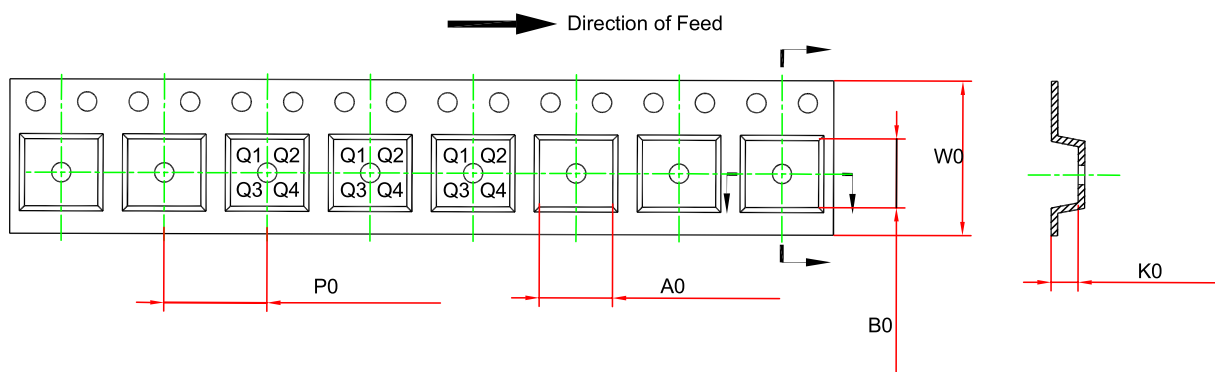
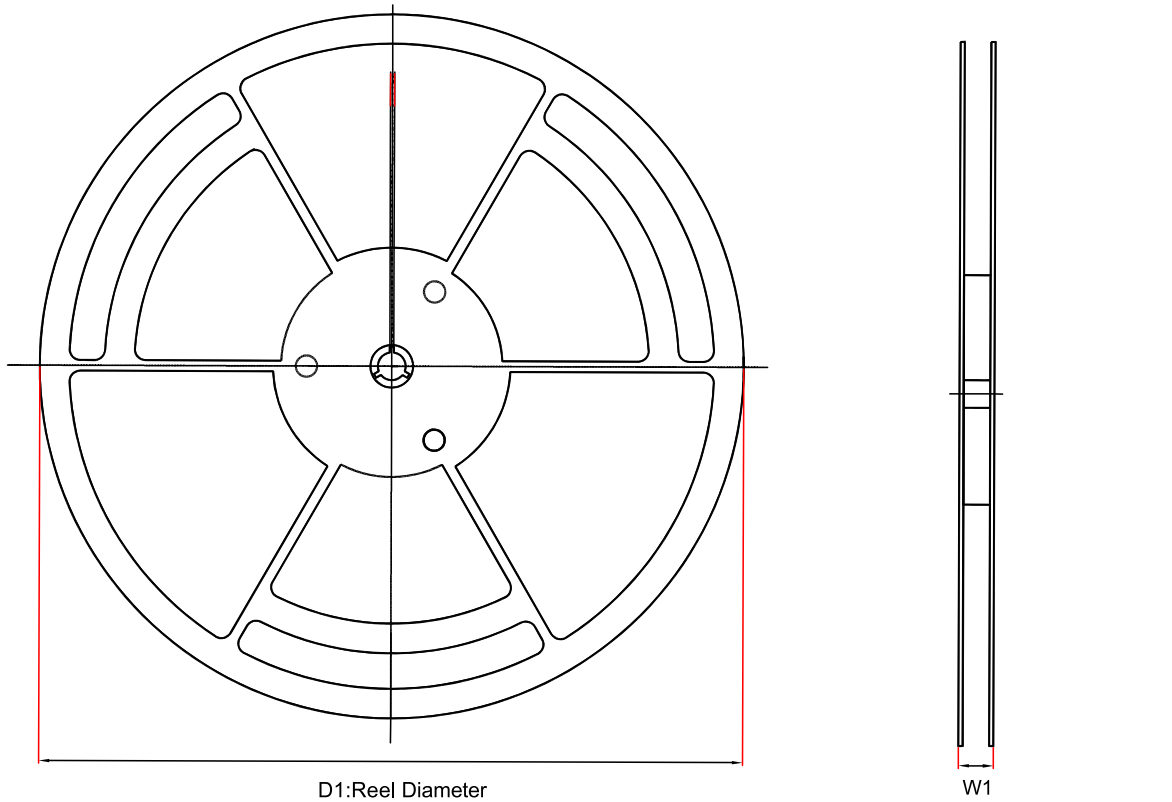

Figure 24. Recommended Layout

### Tape and Reel Information



Order Number	Package	D1 (mm)	W1 (mm)	A0 (mm)	B0 (mm)	K0 (mm)	P0 (mm)	W0 (mm)	Pin1 Quadrant
TPA132A1Q-SO1R-S	SOP8	330	17.6	6.5	5.4	2	8	12	Q1
TPA132A2Q-SO1R-S	SOP8	330	17.6	6.5	5.4	2	8	12	Q1
TPA132A3Q-SO1R-S	SOP8	330	17.6	6.5	5.4	2	8	12	Q1
TPA132A4Q-SO1R-S	SOP8	330	17.6	6.5	5.4	2	8	12	Q1
TPA132A5Q-SO1R-S	SOP8	330	17.6	6.5	5.4	2	8	12	Q1

**Automotive Current-Sense Amplifier with PWM Rejection**

Order Number	Package	D1 (mm)	W1 (mm)	A0 (mm)	B0 (mm)	K0 (mm)	P0 (mm)	W0 (mm)	Pin1 Quadrant
TPA132A1Q-TS1R-S	TSSOP8	330	17.6	6.8	3.4	1.8	8	12	Q1
TPA132A2Q-TS1R-S	TSSOP8	330	17.6	6.8	3.4	1.8	8	12	Q1
TPA132A3Q-TS1R-S	TSSOP8	330	17.6	6.8	3.4	1.8	8	12	Q1
TPA132A4Q-TS1R-S	TSSOP8	330	17.6	6.8	3.4	1.8	8	12	Q1
TPA132A5Q-TS1R-S	TSSOP8	330	17.6	6.8	3.4	1.8	8	12	Q1

Package Outline Dimensions

SOP8

Package Outline Dimensions

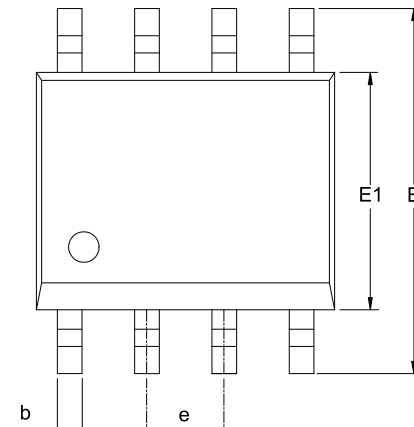
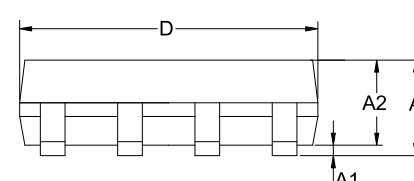
SO1(SOP-8-B)

Symbol	Dimensions In Millimeters		Dimensions In Inches	
	MIN	MAX	MIN	MAX
A	1.350	1.750	0.053	0.069
A1	0.100	0.250	0.004	0.010
A2	1.250	1.550	0.049	0.061
b	0.330	0.510	0.013	0.020
c	0.170	0.250	0.007	0.010
D	4.700	5.100	0.185	0.201
E	5.800	6.200	0.228	0.244
E1	3.800	4.000	0.150	0.157
e	1.270 BSC		0.050 BSC	
L	0.400	1.000	0.016	0.039
θ	0	8°	0	8°

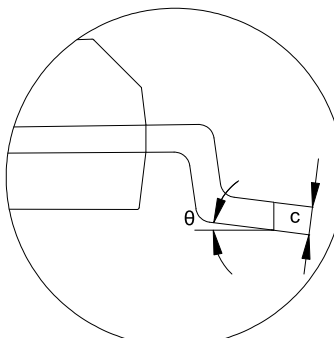
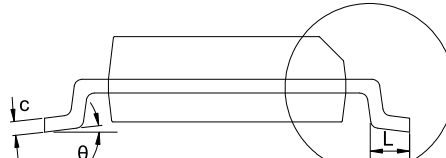
NOTES

1. Do not include mold flash or protrusion.
2. This drawing is subject to change without notice.

TSSOP8

Package Outline Dimensions

TS1(TSSOP-8-A)

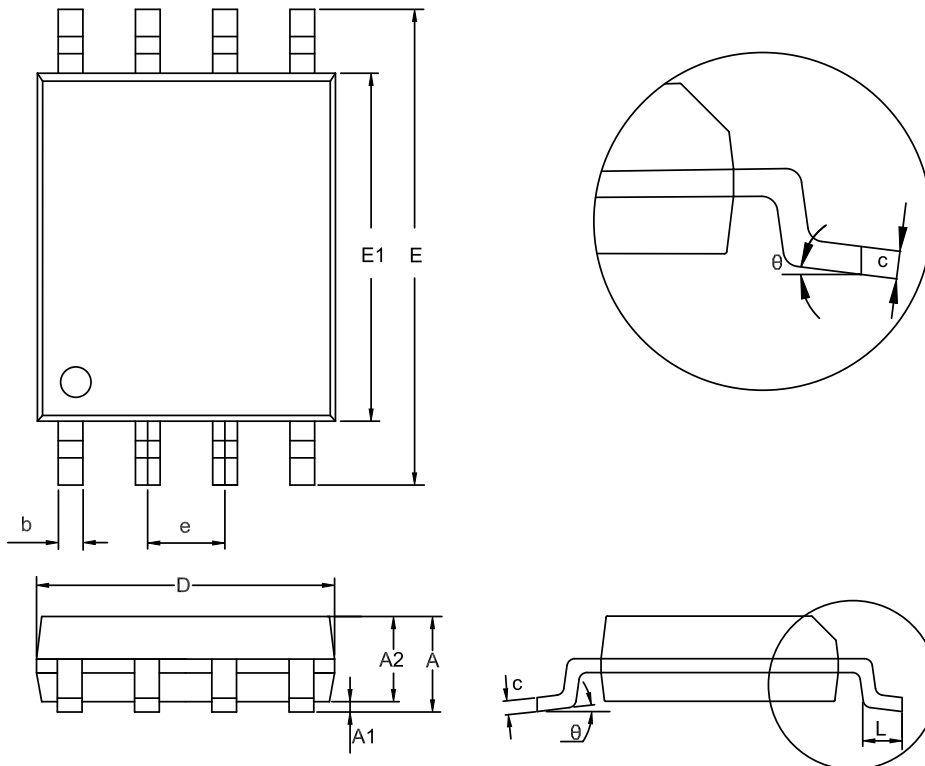

Symbol	Dimensions In Millimeters		Dimensions In Inches	
	MIN	MAX	MIN	MAX
A	0.900	1.200	0.035	0.047
A1	0.050	0.150	0.002	0.006
A2	0.800	1.050	0.031	0.041
b	0.190	0.300	0.007	0.012
c	0.090	0.200	0.004	0.008
D	2.900	3.100	0.114	0.122
E	6.200	6.600	0.244	0.260
E1	4.300	4.500	0.169	0.177
e	0.650 BSC		0.026 BSC	
L	0.450	0.750	0.018	0.030
θ	0	8°	0	8°

NOTES

1. Do not include mold flash or protrusion.
2. This drawing is subject to change without notice.

**Order Information**

Order Number	Gain	Package	Marking Information	MSL	Transport Media, Quantity	Eco Plan
TPA132A1Q-SO1R-S	20 V/V	SOP8	32A1Q	MSL1	Tape and Reel, 4,000	Green
TPA132A2Q-SO1R-S	50 V/V	SOP8	32A2Q	MSL1	Tape and Reel, 4,000	Green
TPA132A3Q-SO1R-S	100 V/V	SOP8	32A3Q	MSL1	Tape and Reel, 4,000	Green
TPA132A4Q-SO1R-S <sup>(1)</sup>	200 V/V	SOP8	32A4Q	MSL1	Tape and Reel, 4,000	Green
TPA132A5Q-SO1R-S <sup>(1)</sup>	500 V/V	SOP8	32A5Q	MSL1	Tape and Reel, 4,000	Green
TPA132A1Q-TS1R-S	20 V/V	TSSOP8	32A1Q	MSL1	Tape and Reel, 3,000	Green
TPA132A2Q-TS1R-S	50 V/V	TSSOP8	32A2Q	MSL1	Tape and Reel, 3,000	Green
TPA132A3Q-TS1R-S	100 V/V	TSSOP8	32A3Q	MSL1	Tape and Reel, 3,000	Green
TPA132A4Q-TS1R-S <sup>(1)</sup>	200 V/V	TSSOP8	32A4Q	MSL1	Tape and Reel, 3,000	Green
TPA132A5Q-TS1R-S <sup>(1)</sup>	500 V/V	TSSOP8	32A5Q	MSL1	Tape and Reel, 3,000	Green

(1) For future products, contact 3PEAK factory for more information and samples.

**Green:** 3PEAK defines "Green" to mean RoHS compatible and free of halogen substances.

## IMPORTANT NOTICE AND DISCLAIMER

**Copyright**© 3PEAK 2012-2025. All rights reserved.

**Trademarks.** Any of the 思瑞浦 or 3PEAK trade names, trademarks, graphic marks, and domain names contained in this document /material are the property of 3PEAK. You may NOT reproduce, modify, publish, transmit or distribute any Trademark without the prior written consent of 3PEAK.

**Performance Information.** Performance tests or performance range contained in this document/material are either results of design simulation or actual tests conducted under designated testing environment. Any variation in testing environment or simulation environment, including but not limited to testing method, testing process or testing temperature, may affect actual performance of the product.

**Disclaimer.** 3PEAK provides technical and reliability data (including data sheets), design resources (including reference designs), application or other design recommendations, networking tools, security information and other resources "As Is". 3PEAK makes no warranty as to the absence of defects, and makes no warranties of any kind, express or implied, including without limitation, implied warranties as to merchantability, fitness for a particular purpose or non-infringement of any third-party's intellectual property rights. Unless otherwise specified in writing, products supplied by 3PEAK are not designed to be used in any life-threatening scenarios, including critical medical applications, automotive safety-critical systems, aviation, aerospace, or any situations where failure could result in bodily harm, loss of life, or significant property damage. 3PEAK disclaims all liability for any such unauthorized use.