

TOLL Plastic-Encapsulate MOSFETS

● Features

- $V_{DS}=40V$
- $I_D=250A$
- $R_{DS(on)}@V_{GS}=10V < 1.3m\Omega$
- Low Gate Charge and R_{dson}
- Fast Switching Speedze
- Advanced Split Gate Trench Technology

Drain-source Voltage

40 V

Drain Current

250 Ampere

● Applications

- PWM Application
- Hard switched and high frequency circuits
- Power Management

● Mechanical Data

- Case: TOLL
Molding compound meets UL 94V-0 flammability rating, RoHS-compliant,halogen-free
- Terminals: Solder plated, solderable per MIL-STD-750,Method 2026

● Function Diagram

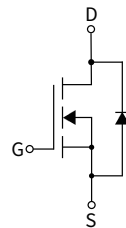
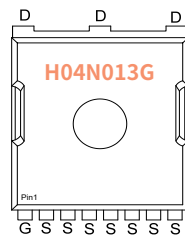

TOLL



● Ordering Information

PACKAGE	PACKAGE CODE	UNIT WEIGHT(g)	REEL(pcs)	BOX(pcs)	CARTON(pcs)	DELIVERY MODE
TOLL	R3	0.753	2000	4000	28000	13"

● Maximum Ratings (Ta=25°C Unless otherwise specified)

PARAMETER	SYMBOL	UNIT	VALUE
Drain-source Voltage	V_{DS}	V	40
Gate-source Voltage	V_{GS}	V	± 20
Drain Current	I_D	A	250
Pulsed Drain Current ⁽¹⁾	I_{DM}	A	1000
Total Power Dissipation	P_D	W	128
Single pulse avalanche energy ⁽²⁾	EAS	mJ	533
Junction temperature	T_J	°C	-55 ~+150
Storage temperature	T_{stg}	°C	-55 ~+150
Thermal Resistance Junction-to-Case	$R_{\theta JC}$	°C / W	0.98

● Static Parameter Characteristics (T_j=25°C Unless otherwise specified)

PARAMETER	SYMBOL	Condition	UNIT	Min	Typ	Max
Drain-Source Breakdown Voltage	BV _{DSS}	V _{GS} = 0V, I _D =250μA	V	40	—	—
Zero Gate Voltage Drain Current	I _{DSS}	V _{DS} =40V, V _{GS} =0V	μA	—	—	1.0
Gate-Body Leakage Current	I _{GSS}	V _{GS} = ±20V, V _{DS} =0V	nA	—	—	±100
Gate Threshold Voltage	V _{GS(th)}	V _{DS} = V _{GS} , I _D =250μA	V	2	3	4
Static Drain-Source On-Resistance ⁽³⁾	R _{DS(ON)}	V _{GS} = 10V, I _D =50A	mΩ	—	1.0	1.3

● Dynamic Parameters

PARAMETER	SYMBOL	Condition	UNIT	Min	Typ	Max
Input Capacitance	C _{iss}	V _{DS} =20V, V _{GS} =0V, f=1MHZ	pF	—	5750	—
Output Capacitance	C _{oss}			—	1950	—
Reverse Transfer Capacitance	C _{rss}			—	169	—

● Switching Parameters

PARAMETER	SYMBOL	Condition	UNIT	Min	Typ	Max
Turn-on Delay Time	t _{D(on)}	V _{GS} =10V, V _{DD} =20V, I _D =85A, R _{GEN} =1.6Ω	nS	—	13.5	—
Turn-on Rise Time	t _r		nS	—	8.8	—
Turn-off Delay Time	t _{D(off)}		nS	—	52	—
Turn-off fall Time	t _f		nS	—	9.6	—
Total Gate Charge	Q _g	V _{DS} =20V, I _D =85A V _{GS} =10V	nC	—	85	—
Gate-Source Charge	Q _{gs}		nC	—	32	—
Gate-Drain Charge	Q _{gd}		nC	—	12.5	—

● Drian-Source Diode Characteristics

PARAMETER	SYMBOL	Condition	UNIT	Min	Typ	Max
Diode Forward Voltage	V _{SD}	I _S =250A, V _{GS} =0V	V	—	—	1.2
Maximum Body-Diode Continuous Current	I _S	—	A	—	—	250
Reverse Recovery Time	T _{rr}	I _S =250A, di/dt=200A/us, T _J =25°C	nS	—	70	—
Reverse Recovery Charge	Q _{rr}		nC	—	96	—

Note :

(1)Repetitive Rating: Pulse width limited by maximum junction temperature.

(2)EAS condition : T_j=25°C, V_{DD}=50V, V_G=10V, L=0.5mH, I_{AS}=46.2A, R_g=25Ω.

(3)Pulse Test: Pulse Width ≤ 300μs, Duty Cycle ≤ 2%.

● Ratings And Characteristics Curves (Ta=25°C Unless otherwise specified)

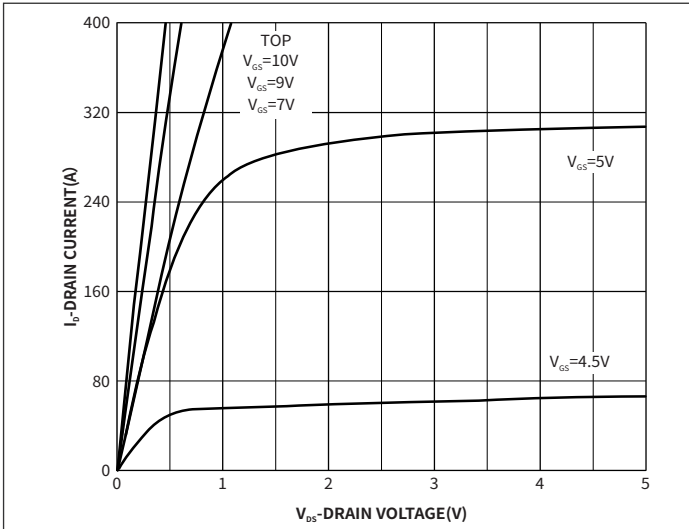

Fig.1 Output Characteristics

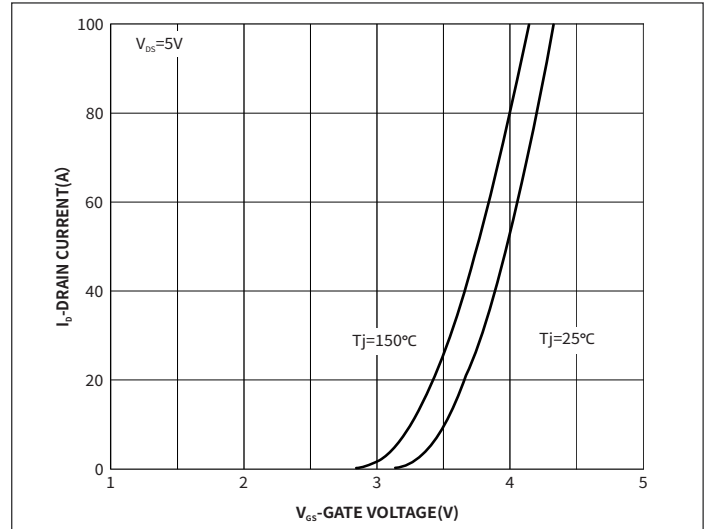

Fig.2 Transfer Characteristics

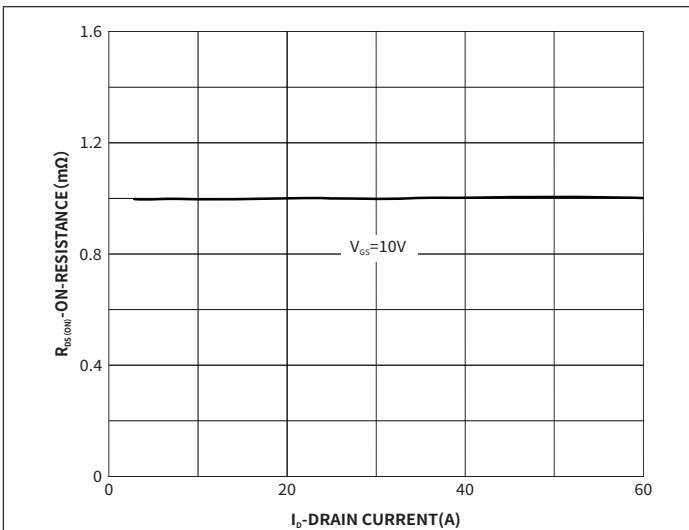

Fig.3 On-Resistance vs. Drain Current and Gate Voltage

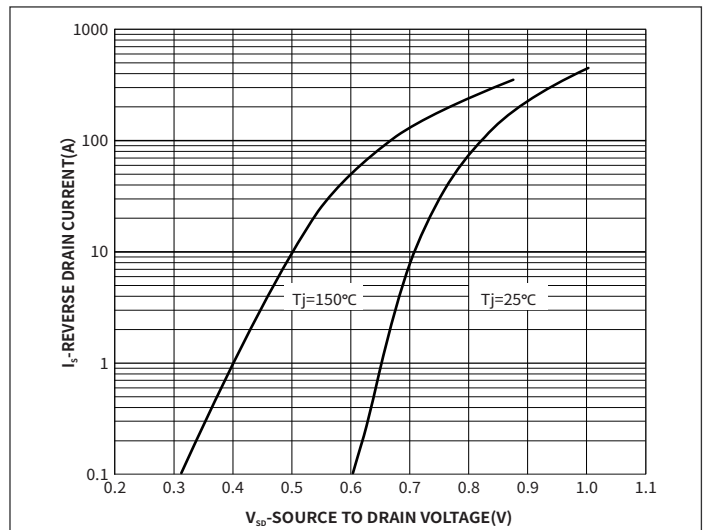

Fig.4 Typical Body-Diode Forward Characteristics

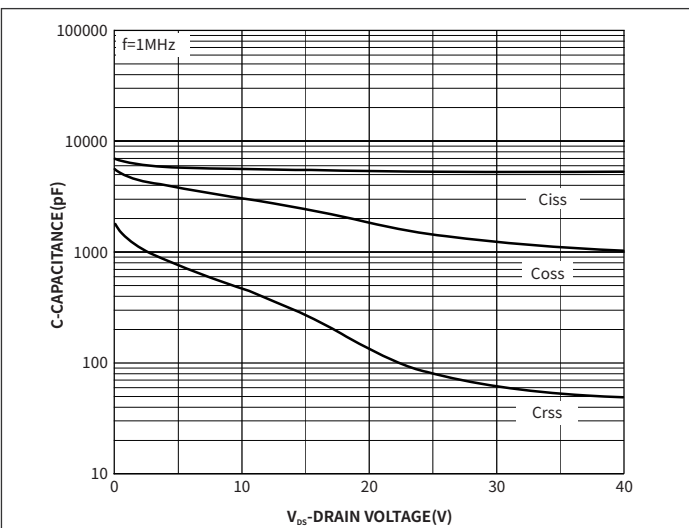

Fig.5 Capacitance Characteristics

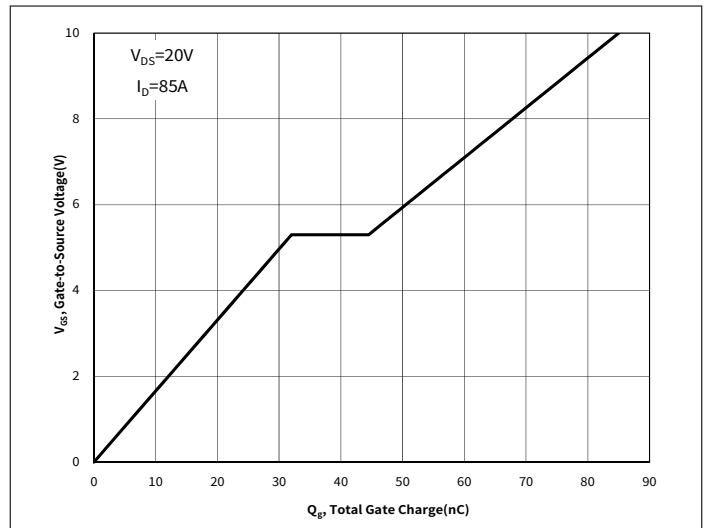
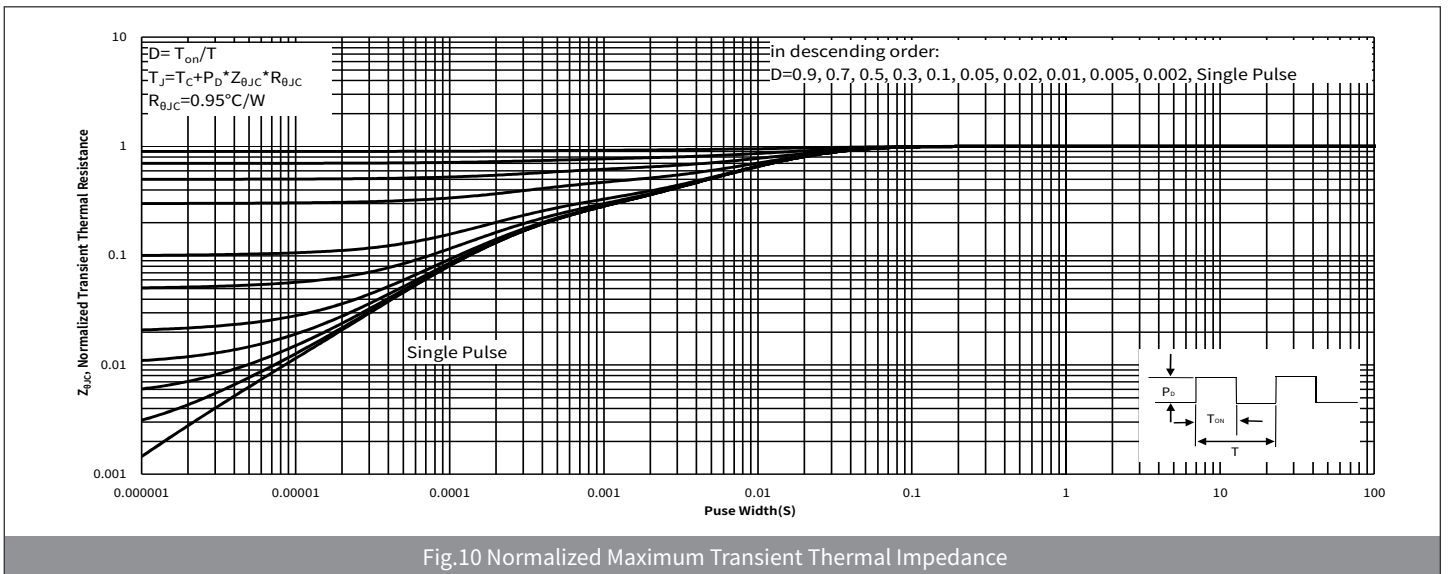
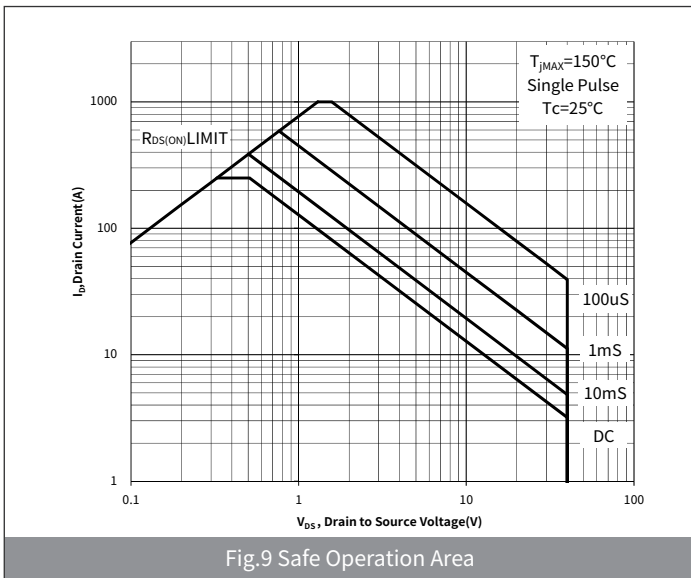
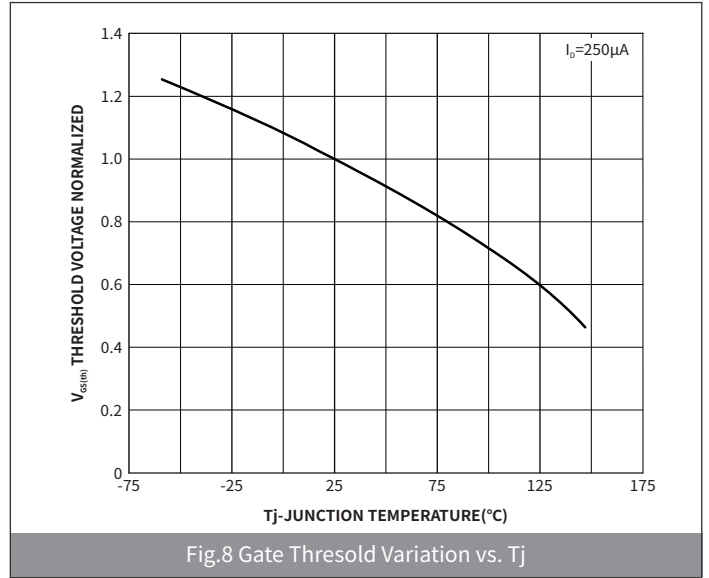
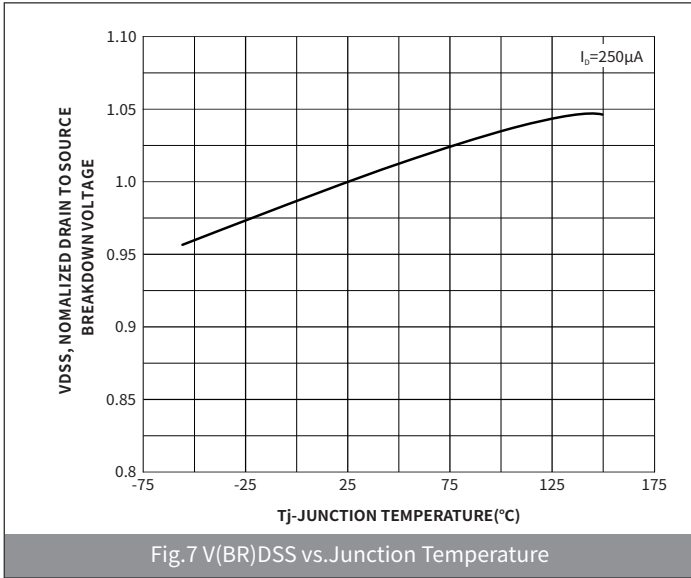

Fig.6 Gate Charge

● Ratings And Characteristics Curves (Ta=25°C Unless otherwise specified)



● Package Outline Dimensions (TOLL)

Symbol	Dimensions			
	Millimeters		Inches	
	Min.	Max.	Min.	Max.
A	2.20	2.4	0.087	0.094
b	0.65	0.90	0.026	0.035
b1	9.7	9.90	0.382	0.390
b3	1.15	1.35	0.045	0.053
c	0.40	0.60	0.016	0.024
D	10.28	10.48	0.405	0.413
D2	3.20	3.40	0.126	0.134
D4	4.45	4.65	0.175	0.183
E	9.80	10.00	0.386	0.394
E1	7.90	8.30	0.311	0.327
E2	2.8	3.20	0.110	0.126
e	1.2BSC		1.2BSC	
H	11.48	11.88	0.452	0.468
H1	6.95REF		6.95REF	
j	0.35REF		0.35REF	
K	3.0REF		3.0REF	
L	1.35	1.75	0.053	0.069
L1	0.50	0.90	0.020	0.035
L2	0.50	0.70	0.020	0.028
L3	0.25	0.65	0.010	0.026
Q	8.0REF		8.0REF	
θ	10° REF		10° REF	

● Suggested Pad Layout

Symbol	Dimensions			
	Millimeters		Inches	
	Min.	Max.	Min.	Max.
A	9.95	10.2	0.392	0.402
A1	2.60	2.80	0.102	0.110
B	8.2	8.3	0.323	0.327
b	0.6	0.8	0.024	0.031
C	0.9	1.1	0.035	0.043
c	0.6	0.8	0.024	0.031
D	6.7	6.9	0.264	0.272
D1	13.1	13.3	0.516	0.524
e	1.0	1.2	0.039	0.047
e1	0.2	0.4	0.008	0.016

1. Gate Charge Test Circuit & Waveforms

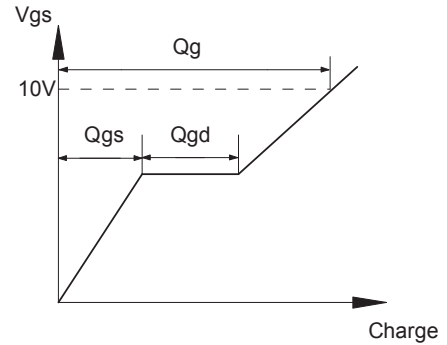
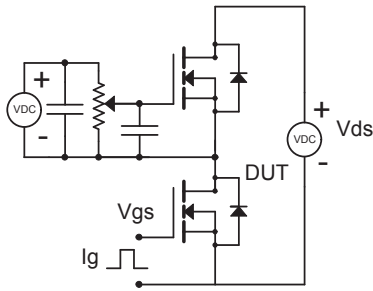

2. Resistive Switching Test Circuit & Waveforms

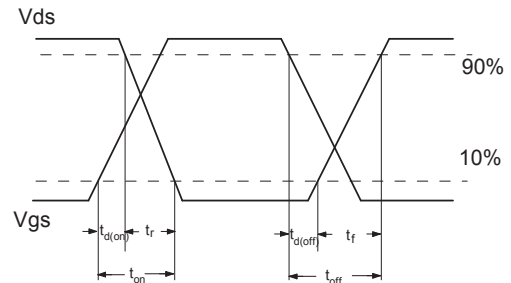
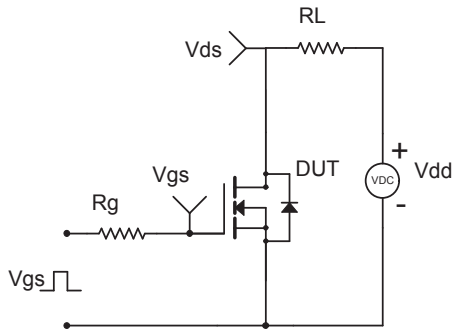

3. Unclamped Inductive Switching (UIS) Test Circuit & Waveforms

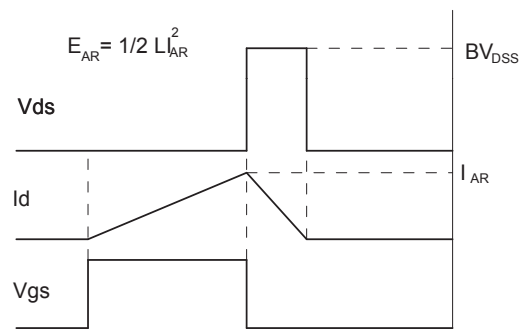
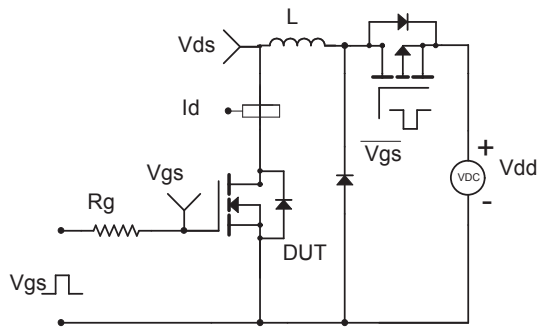

4. Diode Recovery Test Circuit & Waveforms

