

标记 MARK	ECN编号/变更内容 ECN NO/DEFINITION	修改 REVISE	日期 DATE	核准 APPROVE

Pin	DIM A	DIM B
2	3.96	7.92
3	7.92	11.88
4	11.88	15.84
5	15.84	19.80
6	19.80	23.76
7	23.76	27.72
8	27.72	31.68
9	31.68	35.64
10	35.64	39.60
11	39.60	43.56
12	43.56	47.52

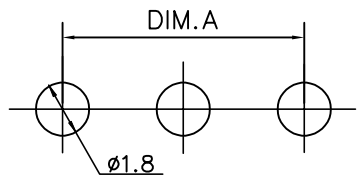
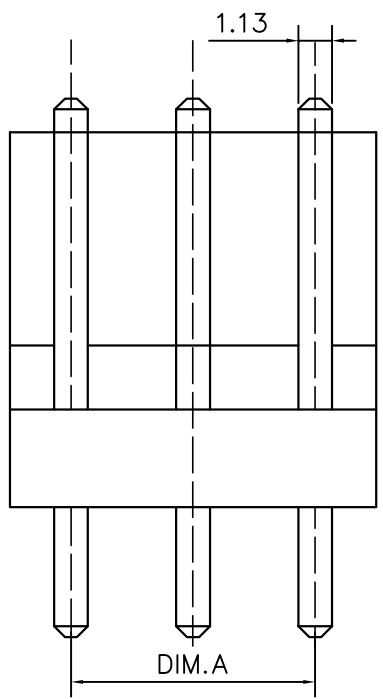
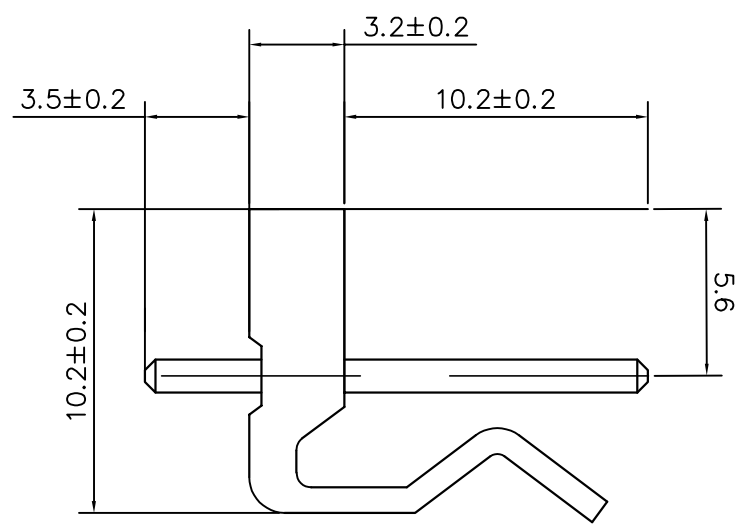
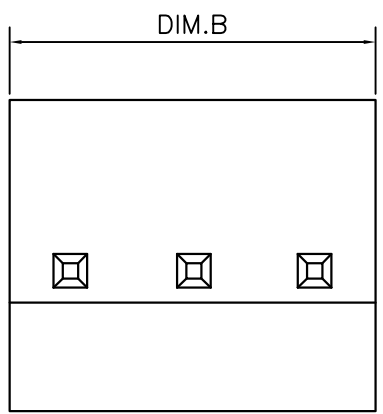

PCB LAYOUT

技术要求:
 适应基板厚度: 1.6mm
 温度范围: -25°C~85°C
 额定电压: 250V AC/DC
 额定电流: 7A AC/DC
 接触电阻: ≤0.02Ω
 绝缘电阻: ≥1000MΩ
 耐 压: 1500V AC/minute

序号	品名	材质	电镀/颜色	备注
2	插针	铜	镀锡	
1	基座	PA66	本色	

	深圳市虹成电子有限公司 TITLE 针座 PART NO HC-CH3.96-4A-T		
	GENERAL TOLERANCES (UNLESS SPECIFIED)	比列 SCALE 1:1	
X.X ±0.35 X.XX ±0.25 X.XXX ±0.15	X' ±3.00' X.X' ±2.00' X.XX' ±1.00'	张数 PART NO 1 OF 1	制图 DRAW AhYe 审核 CHECKED 夏操云 批准 APPROVE 赵亮亮
版本 REV A			

A
B
C
D
E
F
G

A
B
C
D
E
F
G