

标记 MARK	ECN编号/变更内容 ECN NO./DEFINITION	修改 REVISE	日期 DATE	核准 APPROVE

Pin	DIM A	DIM B	DIM C	DIM D
2	6.00	2.00	4.90	0.80
3	8.00	4.00	6.90	2.80
4	10.00	6.00	8.90	4.80
5	12.00	8.00	10.90	6.80
6	14.00	10.00	12.90	8.80
7	16.00	12.00	14.90	10.80
8	18.00	14.00	16.90	12.80
9	20.00	16.00	18.90	14.80
10	22.00	18.00	20.90	16.80
11	24.00	20.00	22.90	18.80
12	26.00	22.00	24.90	20.80
13	28.00	24.00	26.90	22.80
14	30.00	26.00	28.90	24.80
15	32.00	28.00	30.90	26.80
16	34.00	30.00	32.90	28.80

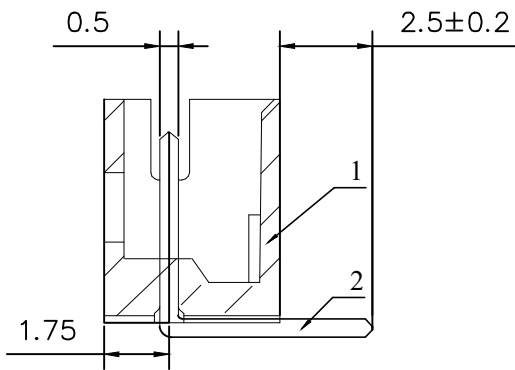
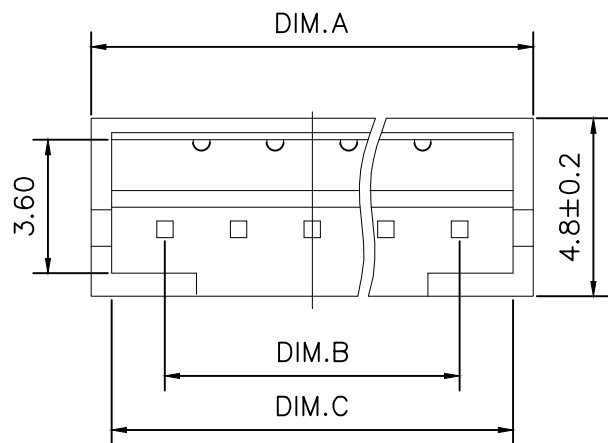

技术要求:

适应基板厚度: 1.2mm~1.6mm

温度范围: -25℃~85℃

额定电压: 200V AC/DC

额定电流: 1A

绝缘电阻: ≥1000MΩ

耐 压: 800V AC/minute

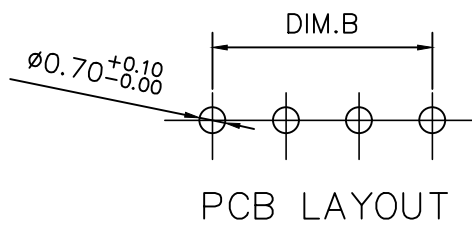
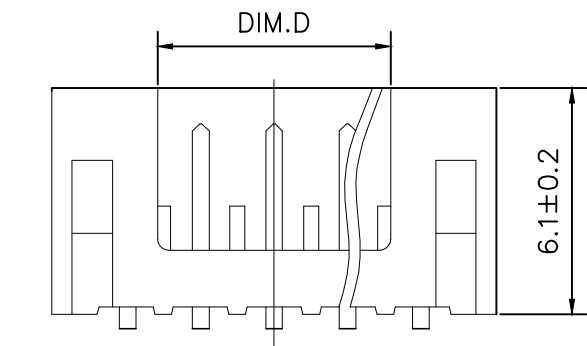

2	插针	铜	镀锡	
1	底座	PA66	米色	
序号	品名	材质	电镀/颜色	备注

	深圳市虹成电子有限公司		品名 TITLE	针座
			料号 PART NO	HC-PH2.0-8AW-M
GENERAL TOLERANCES (UNLESS SPECIFIED)		比列 SCALE	1:1	
X.X ±0.35	X. ±3.00"	单位 UNIT	MM	
X.XX ±0.25	X.X ±2.00"	张数 PART NO	1 OF 1	制图 DRAW
X.XXX ±0.15	X.XX ±1.00"	版本 REV	A	审核 CHECKED
			批准 APPROVE	夏操云
				赵亮亮