

# S8AC-S8MC

Rectifier Diode

## Features

- Super fast switching time for high efficiency
- Low forward voltage drop
- High current capability
- High reliability
- High surge current capability
- Epitaxial construction

## Package

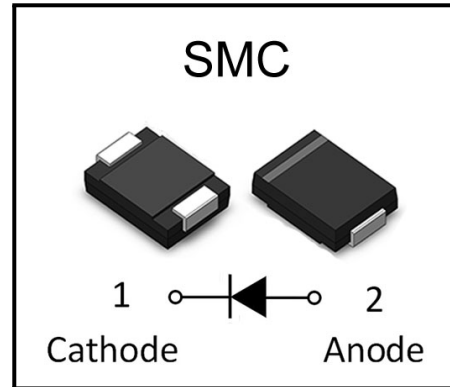

## Description

- Case: molded plastic
- Polarity: Color band denotes cathode
- Package: SMC Plastic Package

## Making Code

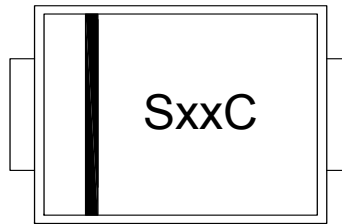

## Ordering information

Part Number	S8AC	S8BC	S8DC	S8GC	S8JC	S8KC	S8MC
Marking	S8AC	S8BC	S8DC	S8GC	S8JC	S8KC	S8MC
Base qty	3K	3K	3K	3K	3K	3K	3K



# S8AC-S8MC

Rectifier Diode

**Maximum Ratings (@T<sub>A</sub>=25°C unless otherwise noted)**

Symbol	Characteristics	S8AC	S8BC	S8DC	S8GC	S8JC	S8KC	S8MC	Unit
V <sub>RRM</sub>	Maximum Recurrent Peak Reverse Voltage	50	100	200	400	600	800	1000	V
V <sub>RMS</sub>	Maximum RMS Voltage	35	70	140	280	420	560	700	V
V <sub>DC</sub>	Maximum DC Blocking Voltage	50	100	200	400	600	800	1000	V
I <sub>(AV)</sub>	Maximum Average Forward Rectified Current at T <sub>L</sub> =100°C	8.0							A
I <sub>FSM</sub>	Peak Forward Surge Current 8.3ms Single half sine-wave Superimposed on Rated Load	200							A
I <sub>FSM</sub>	Peak Forward Surge Current @1ms square wave, 1 cycle	400							A
I <sup>2</sup> t	Current squared time @1ms≤t≤8.3ms	166							A <sup>2</sup> S
V <sub>F</sub>	Maximum Instantaneous Forward Voltage at 8.0A	1.10							V
I <sub>R</sub>	Maximum DC Reverse Current T <sub>A</sub> = 25°C at Rated DC Blocking Voltage T <sub>A</sub> = 125°C	5.0 100							uA
C <sub>J</sub>	Typical Junction Capacitance (Note1)	55							pF
R <sub>θJA</sub>	Typical Thermal Resistance (Note2)	50							°C/W
R <sub>θJL</sub>	Typical Thermal Resistance (Note2)	18							°C/W
R <sub>θJC</sub>	Typical Thermal Resistance (Note2)	15							°C/W
T <sub>J</sub>	Operating Temperature Range	-55 to +150							°C
T <sub>STG</sub>	Storage Temperature Range	-55 to +150							°C

Note: 1. Measured at 1MHz and applied reverse voltage of 4.0V D.C.  
 2. Thermal resistance from junction to ambient and from junction to lead mounted on P.C.B. with 0.6" x 0.6" (16 mm x 16 mm) copper pad areas



# S8AC-S8MC

Rectifier Diode

Typical Performance Characteristics ( $T_J = 25^\circ\text{C}$ , unless otherwise noted)

Figure 1: Derating Curve Output Rectified Current

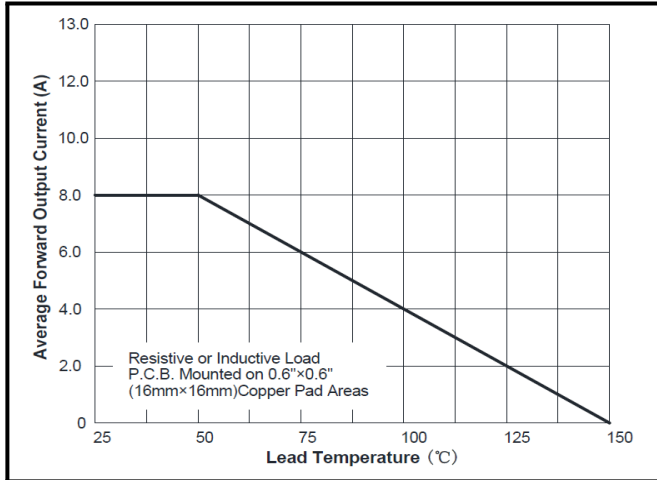

Figure 2: Maximum Non-Repetitive Peak Forward Surge Current PERLEG

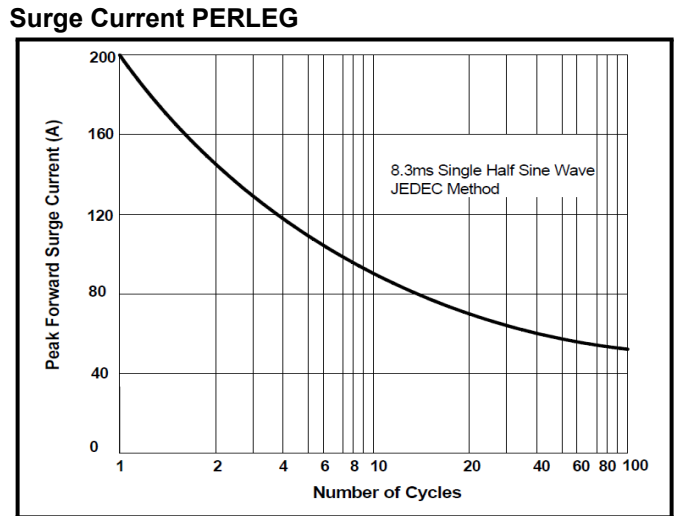

Figure 3: Typical Forward Voltage Characteristics

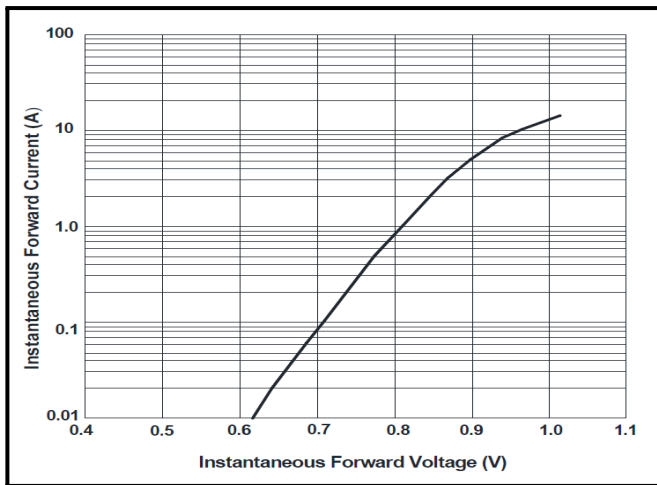
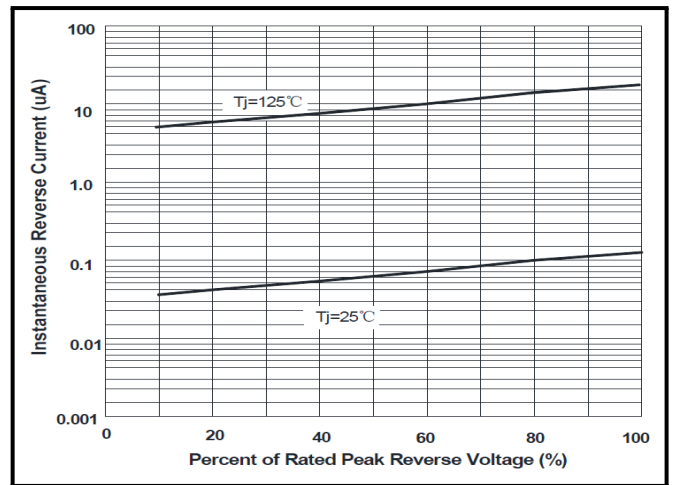
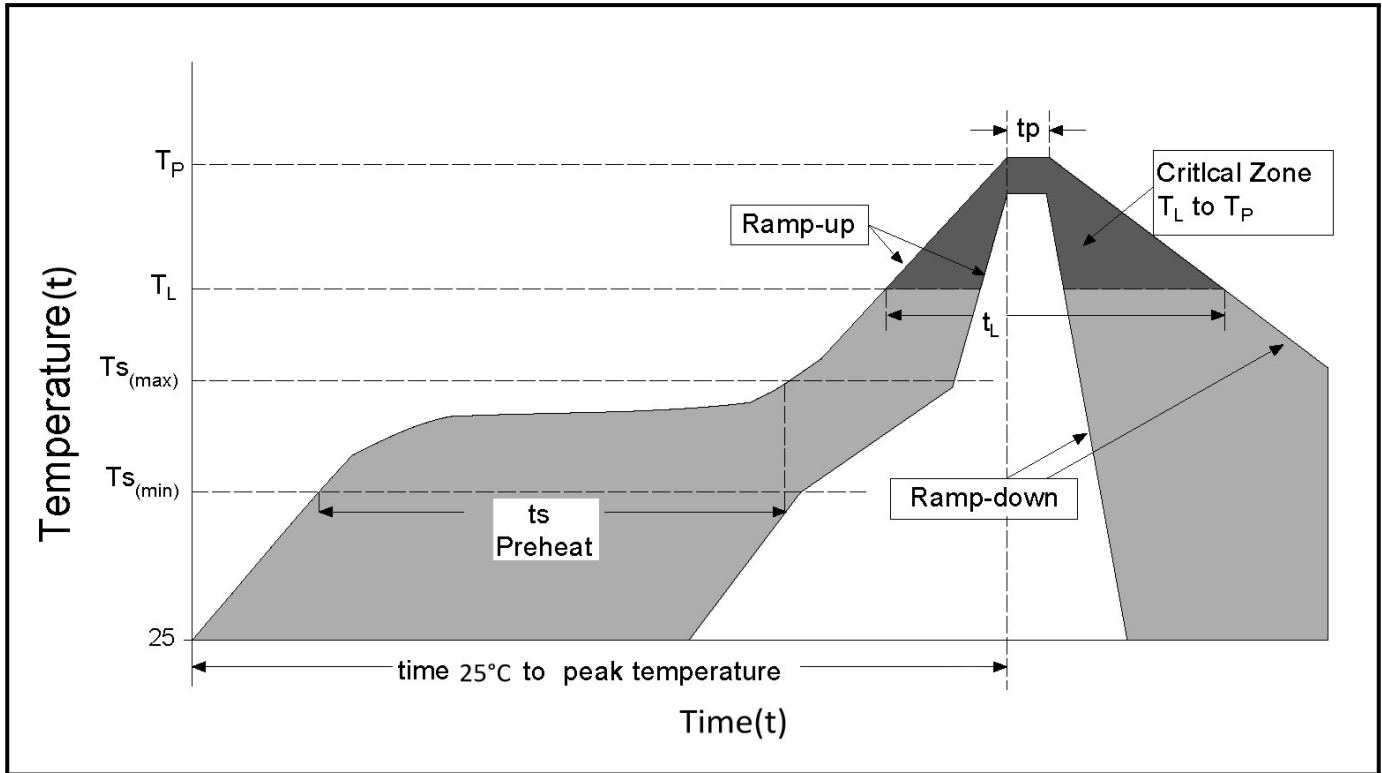

Figure 4: Typical Reverse Leakage Characteristics



**Soldering Parameters**



Reflow Condition		Lead-free assembly
Pre Heat	- Temperature Min ( $T_{S(min)}$ )	150°C
	- Temperature Max ( $T_{S(max)}$ )	200°C
	- Time (min to max) ( $t_s$ )	60 - 180 secs
Average ramp up rate (Liquidus Temp ( $T_L$ ) to peak)		3°C/second max
$T_{S(max)}$ to $T_L$ - Ramp-up Rate		3°C/second max
Reflow	- Temperature ( $T_L$ ) (Liquidus)	217°C
	- Time ( $t_L$ )	60 - 150 secs
Peak Temperature ( $T_P$ )		260 <sup>+0/-5</sup> °C
Time within 5°C of actual peak Temperature ( $t_p$ )		20 - 40 secs
Ramp-down Rate		6°C/second max
Time 25°C to peak Temperature (t)		8 minutes Max.
Do not exceed		260°C



# S8AC-S8MC

Rectifier Diode

## Package Mechanical Data - SMC

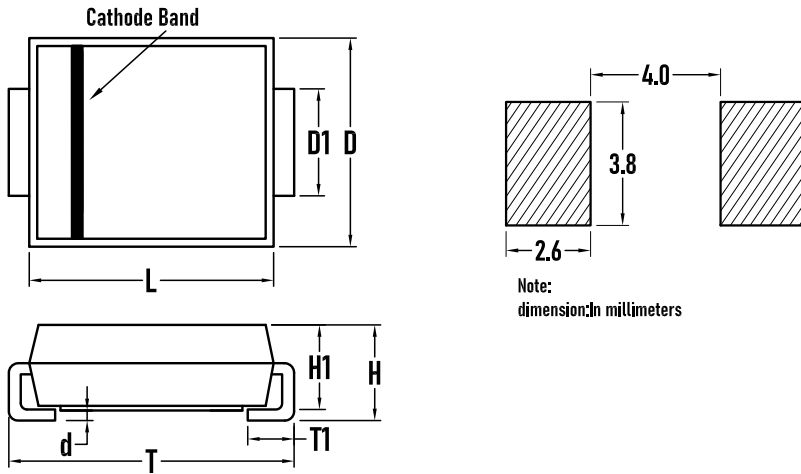

SYMBOL	MILLIMETER		Inches	
	MIN	MAX	MIN	MAX
D	5.5	6.1	0.217	0.240
D1	2.7	3.3	0.106	0.130
T	7.4	8.4	0.291	0.331
T1	0.8	1.6	0.031	0.063
d	—	0.3	—	0.012
H1	2.0	2.6	0.079	0.102
H	2.1	2.7	0.083	0.106
L	6.5	7.1	0.256	0.280

## Packaging Tape - SMC

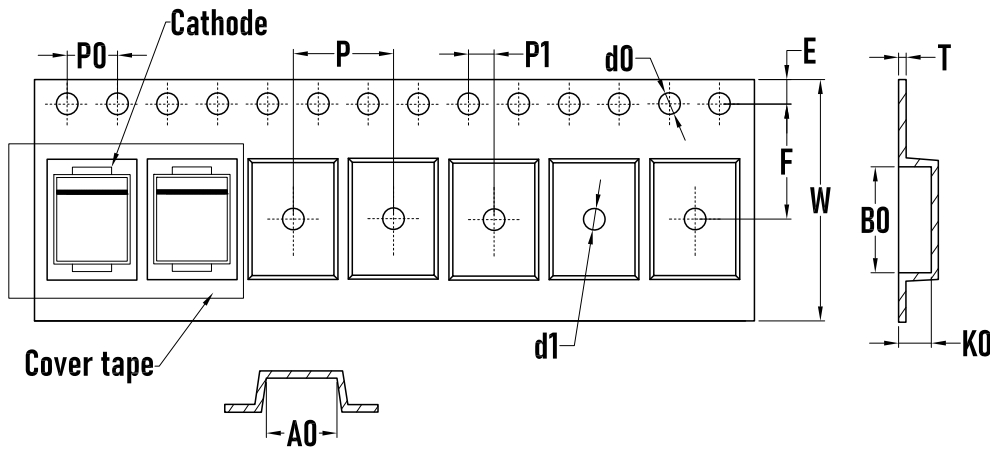

SYMBOL	MILLIMETER
A0	6.00±0.1
B0	8.25±0.02
d0	1.50±0.1
d1	1.50±0.1
E	1.75±0.1
F	7.50±0.1
K0	2.70±0.1
P	8.00±0.1
P0	4.00±0.1
P1	2.00±0.05
W	16.00±0.1
T	0.22±0.02

## Packaging Reel

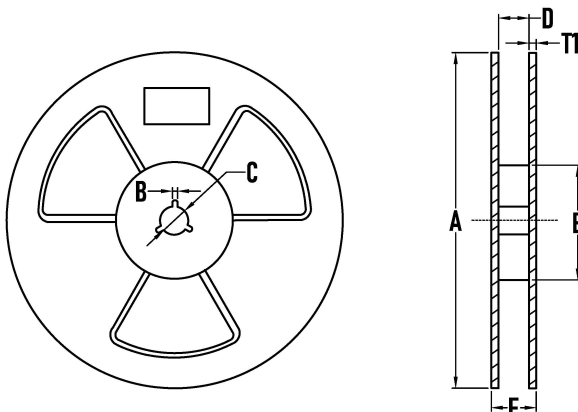

SYMBOL	MILLIMETER
A	323±2
B	3.0±0.2
C	15.0±0.5
D	16±2
E	73±2
T1	2.2±0.2
Quantity	3000PCS

**BORN SEMICONDUCTOR, INC. ALL  
RIGHT RESERVED**

Specifications are subject to change without notice.

Please refer to <http://www.born-tw.com> for current information.

Revision: 2022-Jan-1-A

