



QNHCHIP

QND50N06AJ

Product Specification

QND50N06AJ

60V N-Channel MOSFET



FEATURES

- 60V, 50A
 $R_{DS(ON)}$ Typ = 12m Ω @ $V_{GS} = 10V$
 $R_{DS(ON)}$ Typ = 13m Ω @ $V_{GS} = 4.5V$
- Advanced Trench Technology
- Excellent $R_{DS(ON)}$ and Low Gate Charge

Applications

- Load Switch
- PWM Application
- Power Management

Pin Description

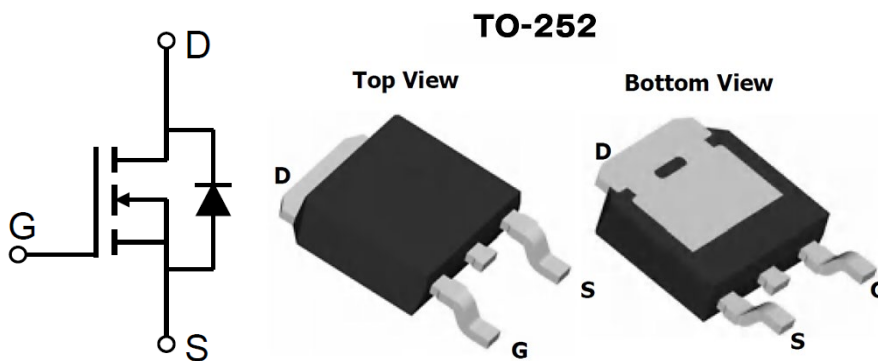

NO.	Symbol	Description
1	G	GATE
2	D	DRAIN
3	S	SOURCE



Absolute Maximum Ratings

(@ $T_A = 25^\circ\text{C}$ unless otherwise specified)

Symbol	Parameter	Value	Units
V_{DS}	Drain-to-Source Voltage	60	V
V_{GS}	Gate-to-Source Voltage	± 20	V
I_D	Continuous Drain Current	$T_A = 25^\circ\text{C}$	50
		$T_A = 100^\circ\text{C}$	30
I_{DM}	Pulsed Drain Current ⁽¹⁾	200	A
E_{AS}	Single Pulsed Avalanche Energy ⁽²⁾	56	mJ
P_D	Power Dissipation	$T_A = 25^\circ\text{C}$	73.5
$R_{\theta JC}$	Thermal Resistance, Junction to Case	1.7	$^\circ\text{C}/\text{W}$
T_J, T_{STG}	Junction & Storage Temperature Range	-55 to 150	$^\circ\text{C}$



Electrical Characteristics

(T_J = 25 °C unless otherwise specified)

Symbol	Parameter	Conditions	Min.	Typ.	Max.	Unit
Off Characteristics						
V _{(BR)DSS}	Drain-Source Breakdown Voltage	I _D =250uA, V _{GS} =0V	60	-	-	V
I _{DSS}	Zero Gate Voltage Drain Current	V _{DS} =60V, V _{GS} =0V	-	-	1.0	uA
I _{GSS}	Gate-Body Leakage Current	V _{DS} =0V, V _{GS} =±20V	-	-	±100	nA
On Characteristics						
V _{GS(th)}	Gate Threshold Voltage	V _{DS} =V _{GS} , I _D =250uA	1	1.6	2	V
R _{DS(on)}	Static Drain-Source ON-Resistance ⁽⁴⁾	V _{GS} =10V, I _D =20A	-	12	16	m Ω
		V _{GS} =4.5V, I _D =10A	-	13	18	m Ω
Dynamic Characteristics						
C _{iss}	Input Capacitance	V _{GS} =0V, V _{DS} =25V, f=1MHz	-	1000	-	pF
C _{oss}	Output Capacitance		-	98	-	pF
C _{rss}	Reverse Transfer Capacitance		-	85	-	pF
Q _g	Total Gate Charge	V _{GS} = 0~-10V, V _{DS} =30V, I _D =30A	-	38	-	nC
Q _{gs}	Gate Source Charge		-	7	-	nC
Q _{gd}	Gate Drain("Miller") Charge		-	10	-	nC
Switching Characteristics						
t _{d(on)}	Turn-On DelayTime	V _{GS} =10V, V _{DD} =30V I _D =30A, R _{GEN} =1.8 Ω	-	10	-	ns
t _r	Turn-On Rise Time		-	35	-	ns
t _{d(off)}	Turn-Off DelayTime		-	28	-	ns
t _f	Turn-Off Fall Time		-	90	-	ns
Drain-Source Diode Characteristics and Max Ratings						
I _S	Maximum Continuous Drain to Source Diode Forward Current		-	-	50	A
I _{SM}	Maximum Pulsed Drain to Source Diode Forward Current		-	-	200	A
V _{SD}	Drain to Source Diode Forward Voltage	V _{GS} = 0V, I _S = 20A	-	-	1.2	V
t _{rr}	Body Diode Reverse Recovery Time	I _F =30A, di/dt = 100A/us	-	13	-	ns
Q _{rr}	Body Diode Reverse Recovery Charge		-	9	-	nC

Notes:

1. Repetitive Rating: Pulse Width Limited by Maximum Junction Temperature.
2. E_{AS} condition: Starting T_J=25 °C, V_{DD}=30V, V_G=10V, R_G=25 Ω, L=0.5mH, I_{AS}=15A
3. Pulse Test: Pulse Width ≤300us, Duty Cycle ≤0.5%.



Test Circuit

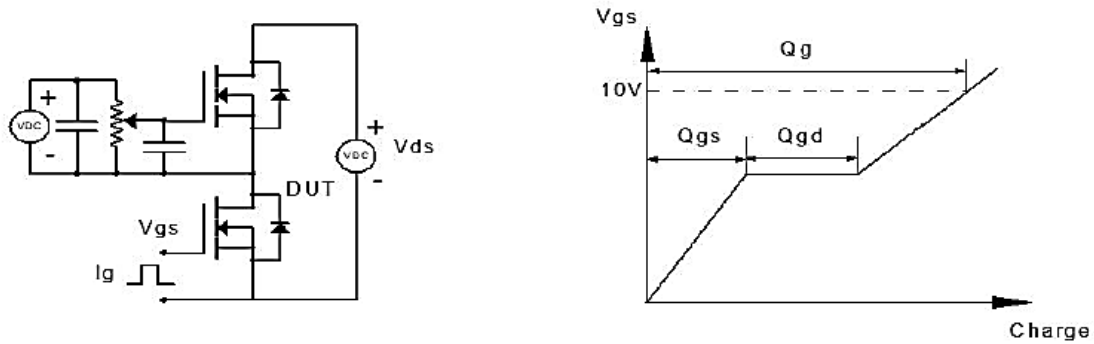

Figure 1: Gate Charge Test Circuit & Waveform

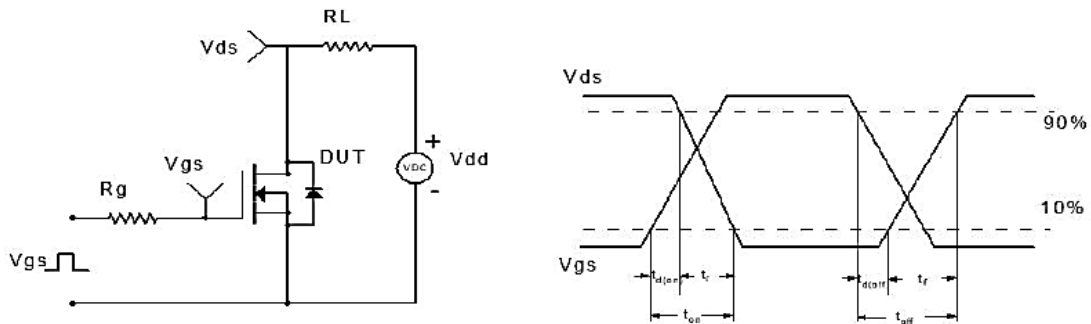

Figure 2: Resistive Switching Test Circuit & Waveform

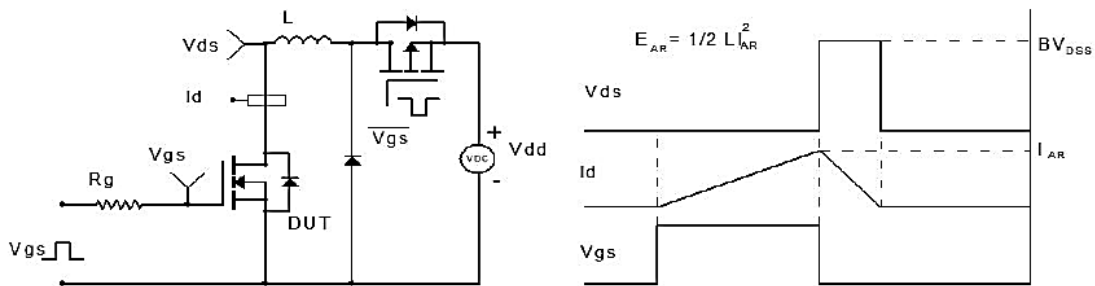

Figure 3: Unclamped Inductive Switching Test Circuit & Waveform

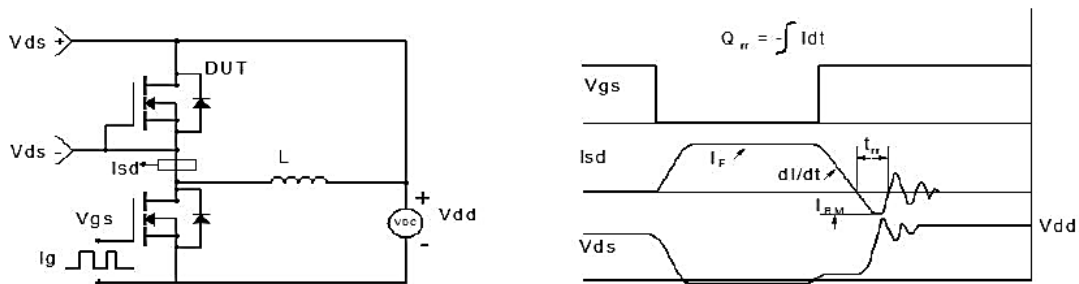
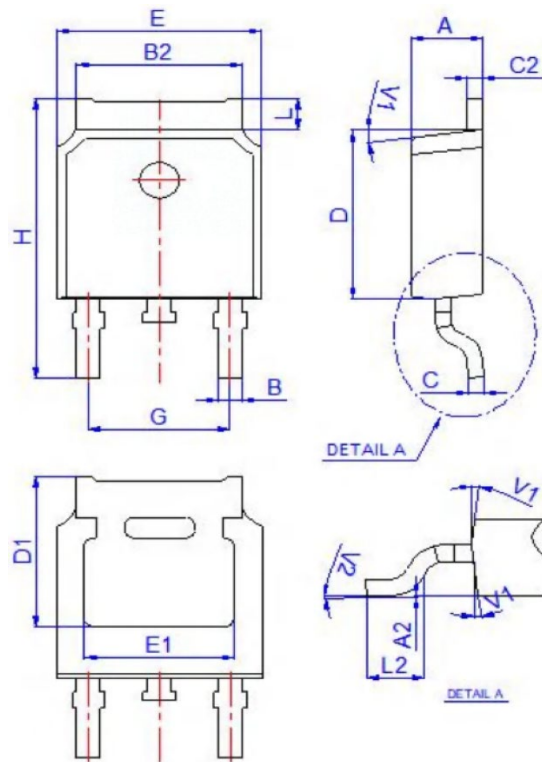

Figure 4: Diode Recovery Test Circuit & Waveform



Package Mechanical Data(TO-252-3L)



Ref.	Dimensions			
	Millimeters		Inches	
	Min.	Max.	Min.	Max.
A	2.10	2.50	0.083	0.098
A2	0	0.10	0	0.004
B	0.66	0.86	0.026	0.034
B2	5.18	5.48	0.202	0.216
C	0.40	0.60	0.016	0.024
C2	0.44	0.58	0.017	0.023
D	5.90	6.30	0.232	0.248
D1	5.30 REF		0.209 REF	
E	6.40	6.80	0.252	0.268
E1	4.63		0.182	
G	4.47	4.67	0.176	0.184
H	9.50	10.70	0.374	0.421
L	1.09	1.21	0.043	0.048
L2	1.35	1.65	0.053	0.065
V1	7°		7°	
V2	0°	6°	0°	6°

Ordering information

Order Code	Package	V _{DS} (V)	I _D (A)	R _{DS(ON)} (m Ω)	
QND50N06AJ	TO-252	60	50	V _{GS} =10V	12
				V _{GS} =4.5V	13