

FEATURES

- 600 Watts Pulse capability
- Excellent clamping capability
- Low incremental surge resistance
- Fast response time
- High temperature soldering guaranteed: 260°C/10 seconds at terminals
- Component in accordance to RoHS 2011/65/EU

MECHANICAL DATA

- * Case: Molded plastic
- * Epoxy: UL 94V-0 rate flame retardant
- * Lead: Solderable per MIL-STD-202, method 208 guaranteed
- * Polarity: Color band denotes cathode end except Bidirectional
- * Mounting position: Any
- * Weight: 0.093 grams



- "GK" represents the brand name
- "XXX" represents the periodic code
- "YYY" represents the product type marking

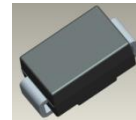

VOLTAGE RANGE

6.8 Volts

600 Watts Peak Power

MAXIMUM RATINGS AND ELECTRICAL CHARACTERISTICS

Rating 25°C ambient temperature unless otherwise specified.
Single phase half wave, 60Hz, resistive or inductive load.
For capacitive load, derate current by 20%.

RATINGS	SYMBOL	VALUE	UNITS
Peak Power Dissipation at $T_A=25^\circ\text{C}$, $T_P=1\text{ms}$ (NOTE 1)	P_{PK}	Minimum 600	Watts
Peak Forward Surge Current at 8.3ms Single Half Sine-Wave superimposed on rated load (JEDEC method) (NOTE 3)	I_{FSM}	100	Amps
Maximum Instantaneous Forward Voltage at 35.0A for Unidirectional only	V_F	3.5	Volts
Typical Thermal Resistance Between junction and case	$R_{\theta J-C}$	20	$^\circ\text{C/W}$
Typical Thermal Resistance Between junction and Air	$R_{\theta J-A}$	95	$^\circ\text{C/W}$
Operating and Storage Temperature Range	T_J, T_{STG}	-55 to +150	$^\circ\text{C}$

NOTES:

1. Non-repetitive current pulse per Fig. 3 and derated above $T_A=25^\circ\text{C}$ per Fig. 2.
2. Mounted on Copper Pad area of 5.0mm^2 (.013mm Thick) to each terminal.
3. 8.3ms single half sine-wave, duty cycle = 4 pulses per minute maximum.

DEVICES FOR BIDIRECTIONAL APPLICATIONS

- 1. For bi-directional use C suffix for Types .
- 2. Electrical characteristics apply in both directions.

Electrical Characteristics ($T_J=25^{\circ}\text{C}$ unless otherwise noted)

Part Number		Marking		Reverse Stand-Off Voltage	Breakdown Voltage V_{BR} (V) @ I_T		Test Current	Maximum Clamping Voltage@ I_{PP}	Peak Pulse Current	Reverse Leakage @ V_{RWM}
Uni	Bi	Uni	Bi	V_{RWM} (V)	Min.	Max.	I_T (mA)	V_C (V)	I_{PP} (A)	I_R (μ A)
SMBJ6.8A	SMBJ6.8CA	P6SMB6.8A	P6SMB6.8CA	5.8	6.45	7.14	10	10.5	57.1	1000

RATING AND CHARACTERISTIC CURVES

FIG.1-PEAK PULSE POWER DERATING CURVE

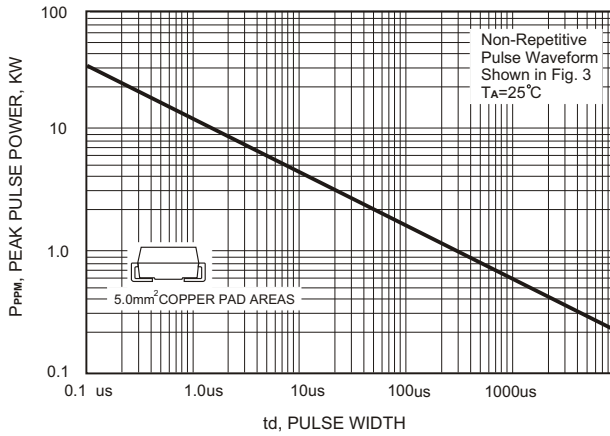

FIG.2-PULSE DERATING CURVE

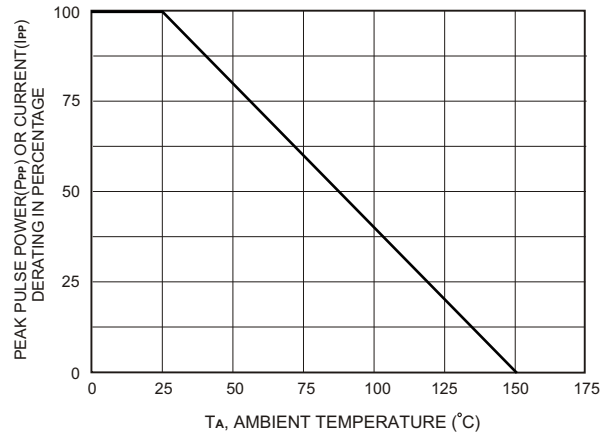

FIG.3-PULSE WAVE FORM

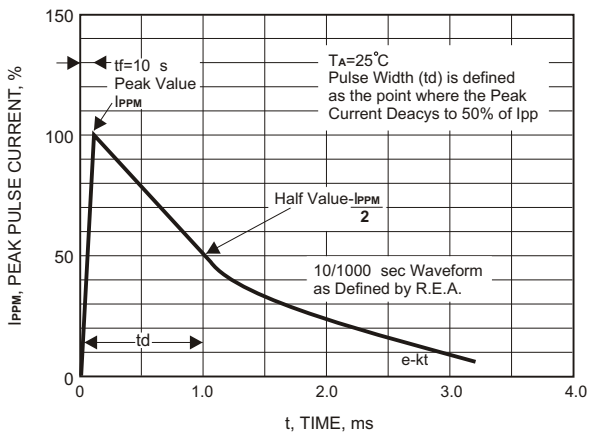

FIG.4-TYPICAL JUNCTION CAPACITANCE

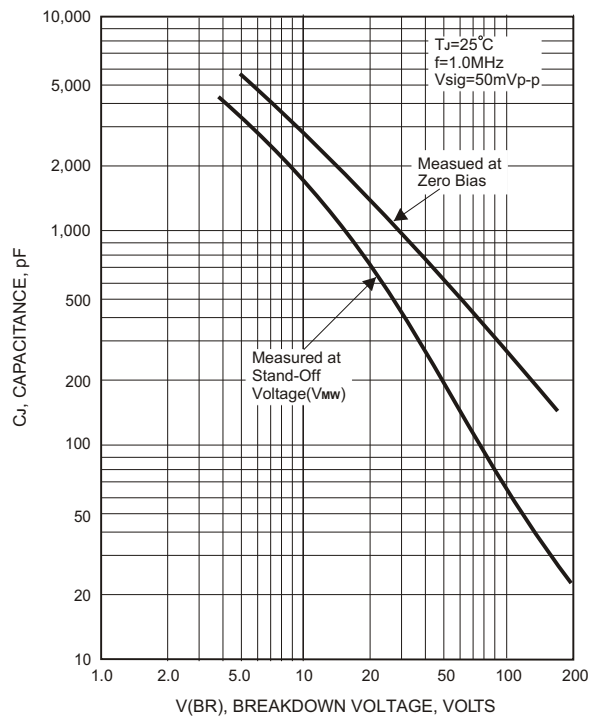
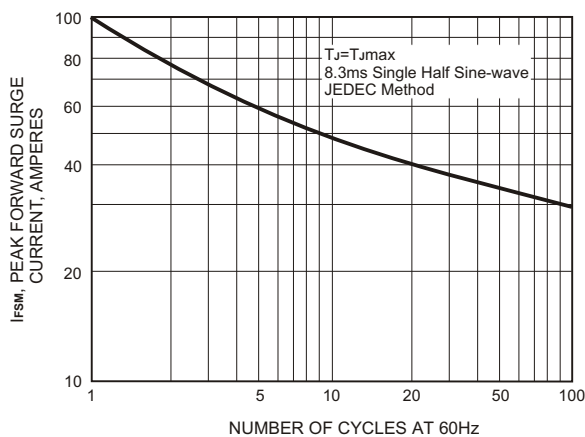
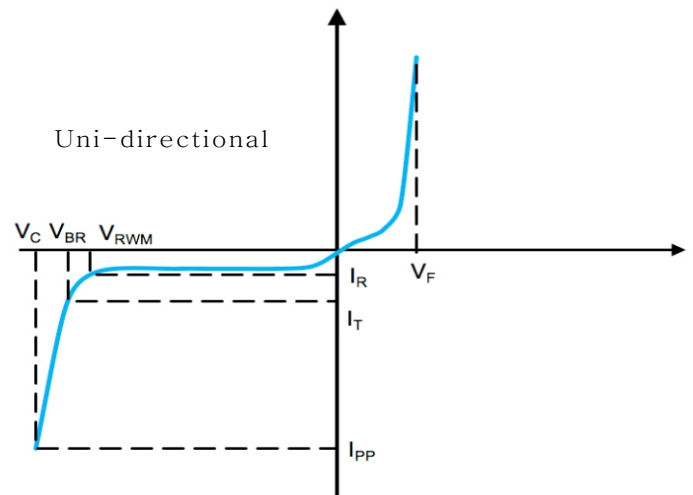
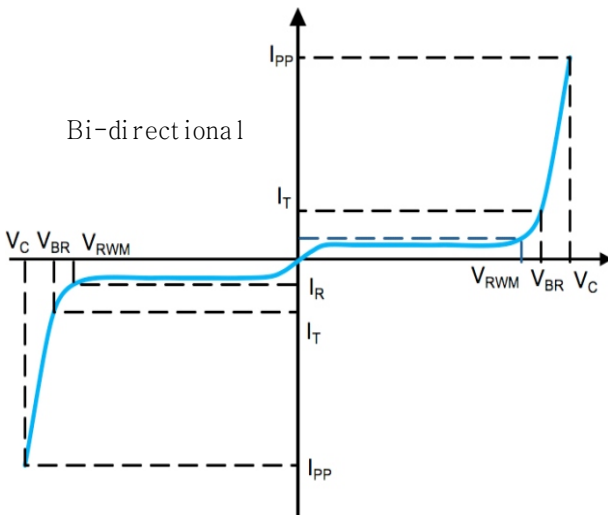

FIG.5-MAXIMUM NON-REPETITIVE PEAK FORWARD SURGE CURRENT



I-V Curve Characteristics



P_{PPM} Peak Pulse Power Dissipation - Max power dissipation

V_{RWM} Reverse Stand-off Voltage - Maximum voltage that can be applied to TVS without operation

V_{BR} Breakdown Voltage – Maximum voltage that flows though the TVS at a specified current (I_T)

V_C Clamping Voltage – Peak vltage measured across the TVS at a specified I_{PPM} (peak impulse current)

I_R Reverse Leakage Current – Current measured at V_R

V_F Forward Voltage Drop for Uni-directional

Soldering parameters

Reflow Condition		Pb-Free assembly (see as below)
Pre Heat	-Temperature Min ($T_{s(min)}$)	+150 °C
	-Temperature Max($T_{s(max)}$)	+200 °C
	-Time (Min to Max) (ts)	60-180 secs.
Average ramp up rate (Liquid us Temp (T_L) to peak)		3 °C/sec. Max
$T_{s(max)}$ to T_L - Ramp-up Rate		3 °C/sec. Max
Reflow	-Temperature(T_L)(Liquid us)	+217 °C
	-Temperature(t_L)	60-150 secs.
Peak Temp (T_P)		+260(+0/-5) °C
Time within 5 °C of actual Peak Temp (t_p)		30 secs. Max
Ramp-down Rate		6 °C/sec. Max
Time 25 °C to Peak Temp (T_P)		8 min. Max
Do not exceed		+260 °C



Package Dimensions & Suggested Pad Layout

SMB

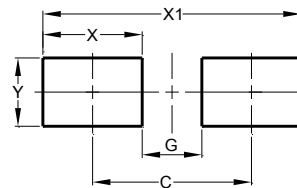
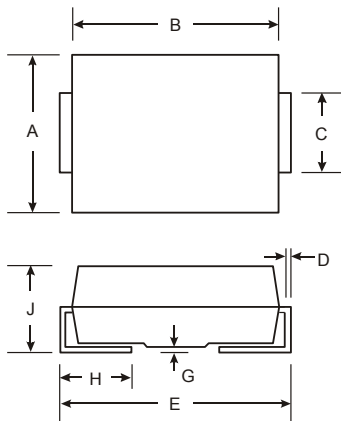

SMB		
Dim	Min	Max
A	3.30	3.94
B	4.06	4.70
C	1.91	2.11
D	0.15	0.31
E	5.08	5.59
G		0.20
H	0.76	1.50
J	2.13	2.44
All Dimensions in mm		

Dimensions	Value (in mm)
C	4.70
G	2.20
X	2.50
X1	7.20
Y	2.80

Tape & reel specification

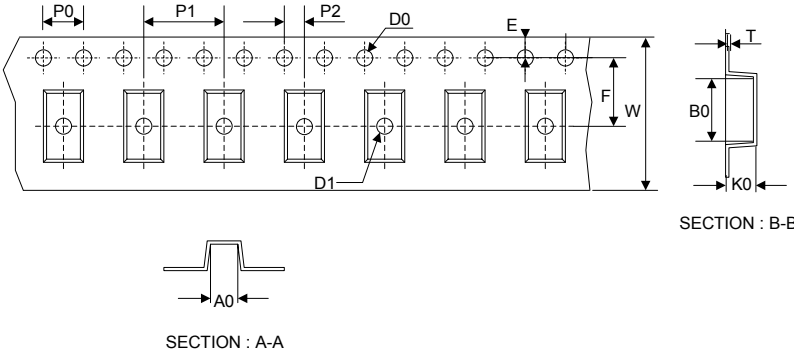
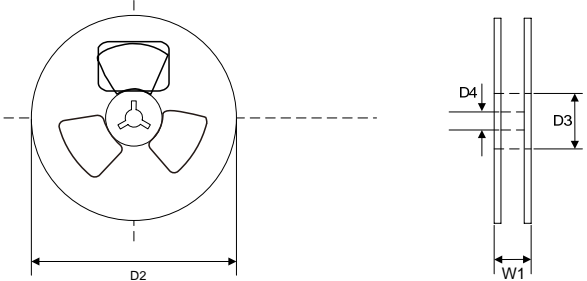
Tape	Symbol	Dimension (mm)	
	P0	4.00±0.20	
	P1	8.00±0.20	
	P2	2.00±0.20	
	D0	1.60±0.20	
	D1	1.60±0.20	
	E	1.75±0.20	
	F	5.50±0.15	
	W	12.00±0.20	
	A0	4.00±0.20	
	B0	5.45±0.20	
	K0	2.50±0.25	
	T	0.20±0.10	
	<p>13" Reel</p> 	D2	330.0±5.0
		D3	73.0Min.
D4		14.0±2.5	
W1		16.0±2.5	
Quantity: 3000PCS			