

General Description

The HSS3132A is the high cell density trenched N-ch MOSFETs, which provides excellent RDSON and efficiency for most of the small power switching and load switch applications.

The HSS3132A meet the RoHS and Green Product requirement with full function reliability approved.

Product Summary

V_{DS}	30	V
$R_{DS(ON),typ}$	220	m Ω
I_D	1	A

Features

- Green Device Available
- Super Low Gate Charge
- Excellent Cdv/dt effect decline
- Advanced high cell density Trench Technology

SOT-23S Pin Configuration

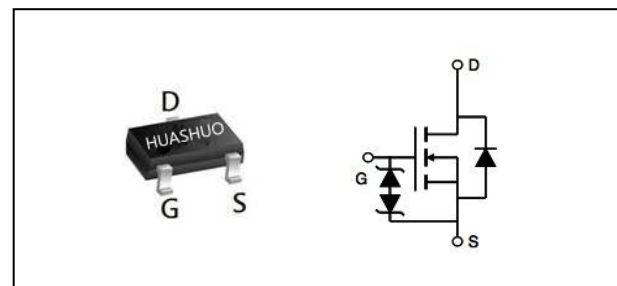

Absolute Maximum Ratings

Symbol	Parameter	Rating	Units
V_{DS}	Drain-Source Voltage	30	V
V_{GS}	Gate-Source Voltage	± 10	V
$I_D@T_A=25^\circ C$	Continuous Drain Current, $V_{GS} @ 10V^1$	1	A
$I_D@T_A=70^\circ C$	Continuous Drain Current, $V_{GS} @ 10V^1$	0.8	A
I_{DM}	Pulsed Drain Current ²	4	A
$P_D@T_A=25^\circ C$	Total Power Dissipation ³	0.75	W
T_{STG}	Storage Temperature Range	-55 to 150	$^\circ C$
T_J	Operating Junction Temperature Range	-55 to 150	$^\circ C$

Thermal Data

Symbol	Parameter	Typ.	Max.	Unit
$R_{\theta JA}$	Thermal Resistance Junction-ambient ¹	---	140	$^\circ C/W$
$R_{\theta JC}$	Thermal Resistance Junction-Case ¹	---	65	$^\circ C/W$



Electrical Characteristics (T_J=25 °C, unless otherwise noted)

Symbol	Parameter	Conditions	Min.	Typ.	Max.	Unit
BV _{DSS}	Drain-Source Breakdown Voltage	V _{GS} =0V, I _D =250uA	30	---	---	V
ΔBV _{DSS} /ΔT _J	BVDSS Temperature Coefficient	Reference to 25°C, I _D =1mA	---	0.023	---	V/°C
R _{DS(ON)}	Static Drain-Source On-Resistance ²	V _{GS} =4.5V, I _D =0.5A	---	220	270	mΩ
		V _{GS} =2.5V, I _D =0.3A	---	280	350	
V _{GS(th)}	Gate Threshold Voltage	V _{GS} =V _{DS} , I _D =250uA	0.4	0.7	1	V
ΔV _{GS(th)}	V _{GS(th)} Temperature Coefficient		---	-4.2	---	mV/°C
I _{DSS}	Drain-Source Leakage Current	V _{DS} =24V, V _{GS} =0V, T _J =25°C	---	---	1	uA
		V _{DS} =24V, V _{GS} =0V, T _J =55°C	---	---	5	
I _{GSS}	Gate-Source Leakage Current	V _{GS} =±10V, V _{DS} =0V	---	---	±10	uA
R _g	Gate Resistance	V _{DS} =0V, V _{GS} =0V, f=1MHz	---	21	---	Ω
Q _g	Total Gate Charge (4.5V)	V _{DS} =15V, V _{GS} =4.5V, I _D =0.5A	---	1.5	---	nC
Q _{gs}	Gate-Source Charge		---	0.4	---	
Q _{gd}	Gate-Drain Charge		---	0.1	---	
T _{d(on)}	Turn-On Delay Time	V _{DD} =15V, V _{GS} =10V, R _G =3.3Ω I _D =0.5A	---	12	---	ns
T _r	Rise Time		---	9	---	
T _{d(off)}	Turn-Off Delay Time		---	62	---	
T _f	Fall Time		---	28	---	
C _{iss}	Input Capacitance	V _{DS} =15V, V _{GS} =0V, f=1MHz	---	51	---	pF
C _{oss}	Output Capacitance		---	8	---	
C _{riss}	Reverse Transfer Capacitance		---	4	---	

Diode Characteristics

Symbol	Parameter	Conditions	Min.	Typ.	Max.	Unit
I _S	Continuous Source Current ^{1,4}	V _G =V _D =0V, Force Current	---	---	1	A
I _{SM}	Pulsed Source Current ^{2,4}		---	---	4	A
V _{SD}	Diode Forward Voltage ²	V _{GS} =0V, I _S =1A, T _J =25°C	---	---	1.2	V

Note :

- 1.The data tested by surface mounted on a 1 inch² FR-4 board with 2OZ copper.
- 2.The data tested by pulsed, pulse width ≤ 300us, duty cycle ≤ 2%
- 3.The power dissipation is limited by 150°C junction temperature
- 4.The data is theoretically the same as I_D and I_{DM}, in real applications, should be limited by total power dissipation.

Typical Characteristics

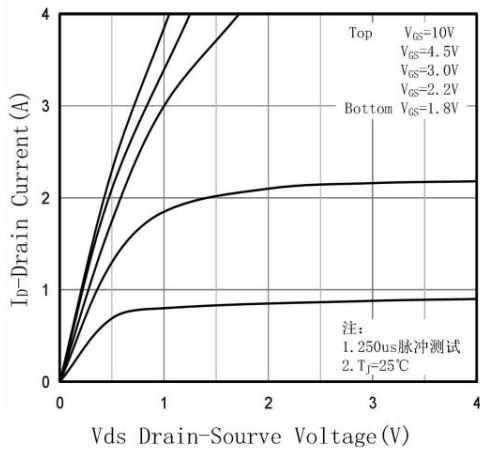

Fig.1 Output Characteristic

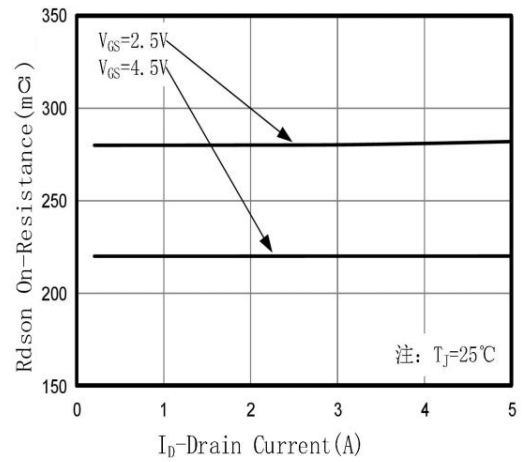

Fig.2 On-Resistance vs. Drain Current

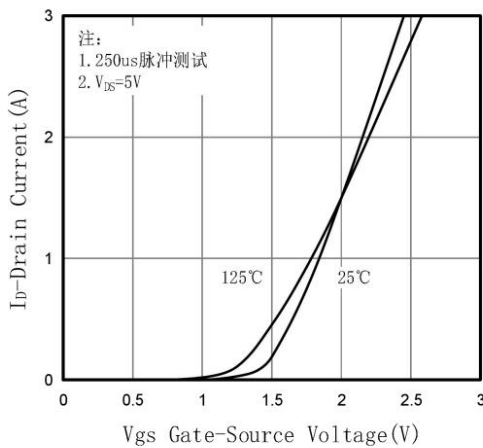

Fig.3 Transfer Characteristic

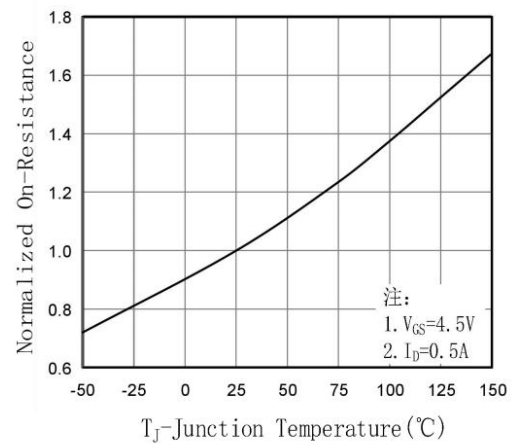

Fig.4 On-Resistance vs. Junction Temperature

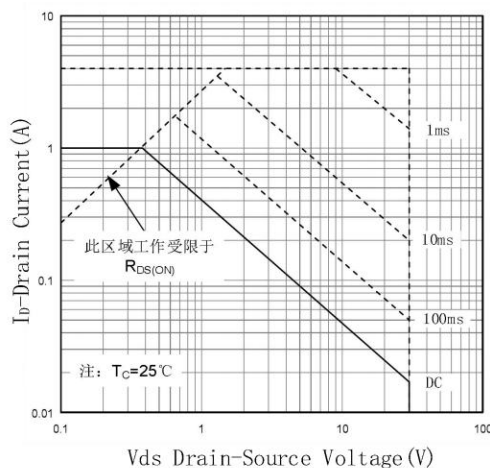

Fig.5 Safe Operation Area

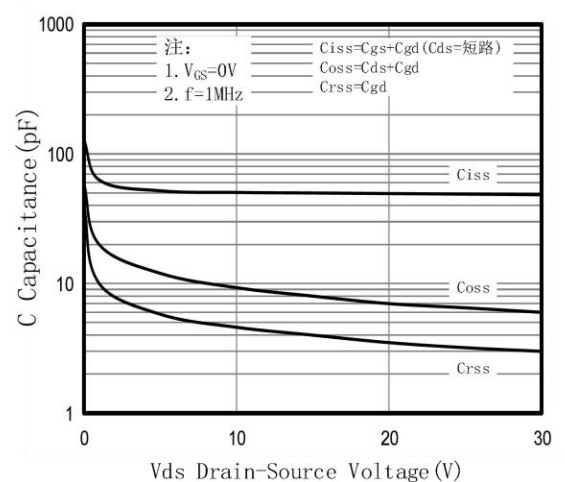

Fig.6 Capacitance Characteristic



N-Ch 30V Fast Switching MOSFETs

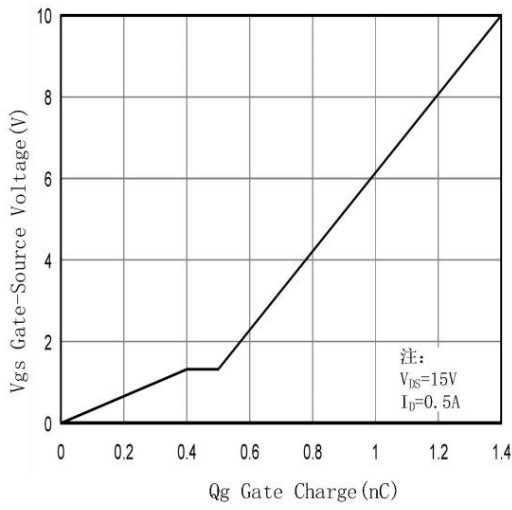

Fig.7 Gate-Charge Characteristic

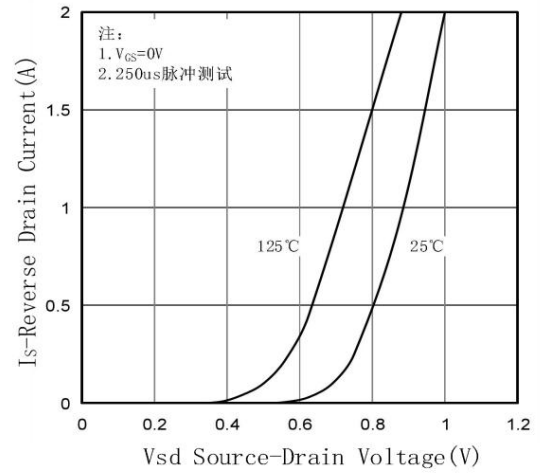

Fig.8 Body Diode Characteristic

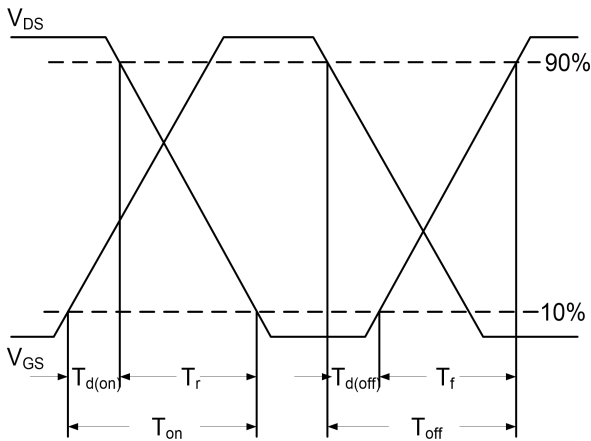

Fig.9 Switching Time Waveform

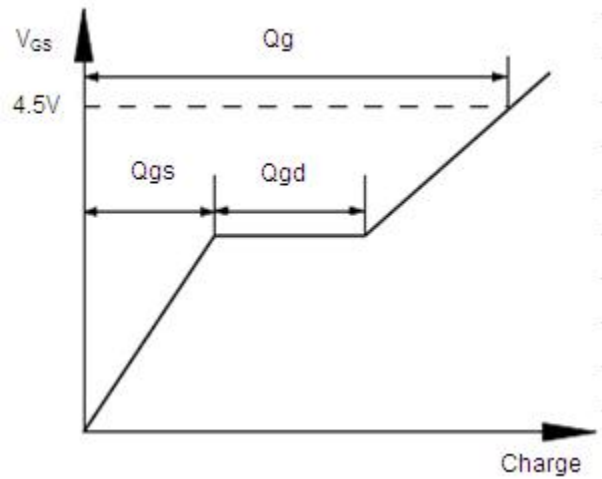
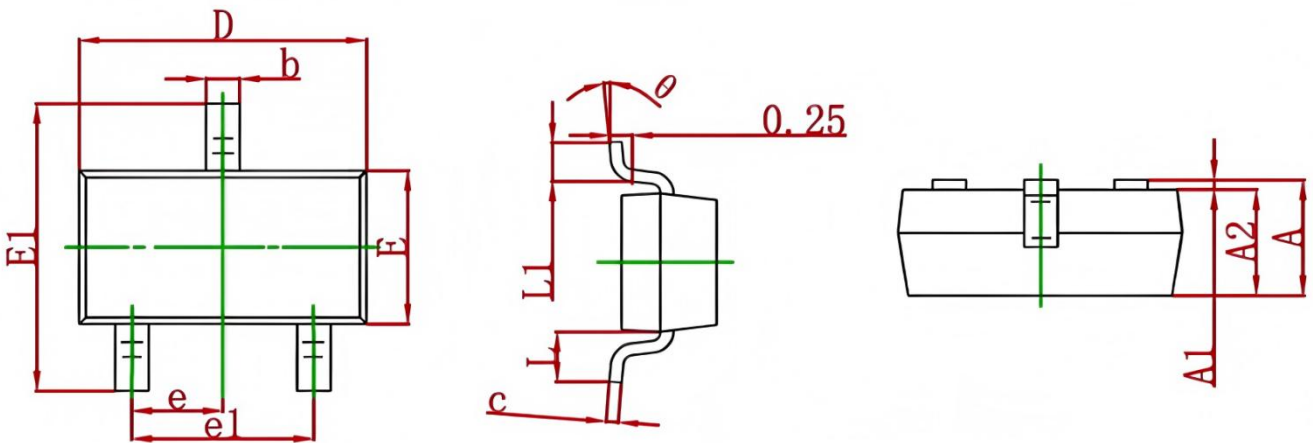

Fig.10 Gate Charge Waveform

Ordering Information

Part Number	Package code	Packaging
HSS3132A	SOT-23S	3000/Tape&Reel

SOT-23S Package Outline



Symbol	Dimensions In Millimeters		Dimensions In Inches	
	Min	Max	Min	Max
A	0.900	1.150	0.035	0.045
A1	0.000	0.100	0.000	0.004
A2	0.900	1.050	0.035	0.041
b	0.300	0.500	0.012	0.020
C	0.080	0.150	0.003	0.006
D	2.800	3.000	0.110	0.118
E	1.200	1.400	0.047	0.055
E1	2.250	2.550	0.089	0.100
e	0.950 TYP		0.037 TYP	
e1	1.800	2.000	0.071	0.079
L	0.550 REF		0.022 REF	
L1	0.300	0.500	0.012	0.020
θ	0°	8°	0°	8°



HSS3132A TOP Marking

