

## General Description

The HSM4406L is the high cell density trenched N-ch MOSFETs, which provide excellent RDSON and gate charge for most of the synchronous buck converter applications.

The HSM4406L meet the RoHS and Green Product requirement, 100% EAS guaranteed with full function reliability approved.

## Features

- Super Low Gate Charge
- 100% EAS Guaranteed
- Green Device Available
- Excellent CdV/dt effect decline
- Advanced high cell density Trench Technology

## Product Summary

$V_{DS}$	30	V
$R_{DS(ON),typ}$	7.2	m $\Omega$
$I_D$	13	A

## SOP8 Pin Configuration

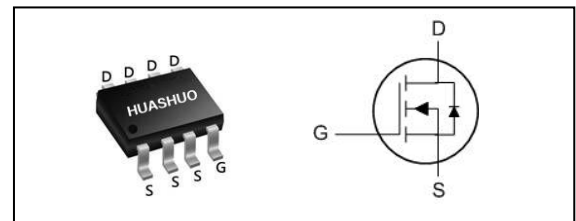

## Absolute Maximum Ratings

Symbol	Parameter	Rating	Units
$V_{DS}$	Drain-Source Voltage	30	V
$V_{GS}$	Gate-Source Voltage	$\pm 12$	V
$I_D@T_A=25^\circ\text{C}$	Continuous Drain Current, $V_{GS}$ @ 10V <sup>1</sup>	13	A
$I_D@T_A=70^\circ\text{C}$	Continuous Drain Current, $V_{GS}$ @ 10V <sup>1</sup>	10	A
$I_{DM}$	Pulsed Drain Current <sup>2</sup>	40	A
$P_D@T_A=25^\circ\text{C}$	Total Power Dissipation <sup>4</sup>	2	W
$T_{STG}$	Storage Temperature Range	-55 to 150	$^\circ\text{C}$
$T_J$	Operating Junction Temperature Range	-55 to 150	$^\circ\text{C}$

## Thermal Data

Symbol	Parameter	Typ.	Max.	Unit
$R_{\theta JA}$	Thermal Resistance Junction-ambient <sup>1</sup>	---	50	$^\circ\text{C/W}$
$R_{\theta JC}$	Thermal Resistance Junction-Case <sup>1</sup>	---	25	$^\circ\text{C/W}$



**Electrical Characteristics (T<sub>J</sub>=25 °C, unless otherwise noted)**

Symbol	Parameter	Conditions	Min.	Typ.	Max.	Unit
BV <sub>DSS</sub>	Drain-Source Breakdown Voltage	V <sub>GS</sub> =0V, I <sub>D</sub> =250uA	30	---	---	V
R <sub>DS(ON)</sub>	Static Drain-Source On-Resistance <sup>2</sup>	V <sub>GS</sub> =10V, I <sub>D</sub> =6A	---	7.2	10	mΩ
		V <sub>GS</sub> =4.5V, I <sub>D</sub> =5A	---	8	12	
		V <sub>GS</sub> =2.5V, I <sub>D</sub> =4A	---	10	16	
V <sub>GS(th)</sub>	Gate Threshold Voltage	V <sub>GS</sub> =V <sub>DS</sub> , I <sub>D</sub> =250uA	0.5	0.9	1.5	V
I <sub>DSS</sub>	Drain-Source Leakage Current	V <sub>DS</sub> =24V, V <sub>GS</sub> =0V, T <sub>J</sub> =25°C	---	---	1	uA
		V <sub>DS</sub> =24V, V <sub>GS</sub> =0V, T <sub>J</sub> =55°C	---	---	5	
I <sub>GSS</sub>	Gate-Source Leakage Current	V <sub>GS</sub> =±20V, V <sub>DS</sub> =0V	---	---	±100	nA
R <sub>g</sub>	Gate Resistance	V <sub>DS</sub> =0V, V <sub>GS</sub> =0V, f=1MHz	---	1.4	---	Ω
Q <sub>g</sub>	Total Gate Charge (4.5V)	V <sub>DS</sub> =15V, V <sub>GS</sub> =4.5V, I <sub>D</sub> =5A	---	15	---	nC
Q <sub>gs</sub>	Gate-Source Charge		---	1.8	---	
Q <sub>gd</sub>	Gate-Drain Charge		---	11.5	---	
T <sub>d(on)</sub>	Turn-On Delay Time	V <sub>DD</sub> =15V, V <sub>GS</sub> =10V, R <sub>G</sub> =6Ω I <sub>D</sub> =5A	---	15	---	ns
T <sub>r</sub>	Rise Time		---	16	---	
T <sub>d(off)</sub>	Turn-Off Delay Time		---	27	---	
T <sub>f</sub>	Fall Time		---	15	---	
C <sub>iss</sub>	Input Capacitance	V <sub>DS</sub> =15V, V <sub>GS</sub> =0V, f=1MHz	---	1850	---	pF
C <sub>oss</sub>	Output Capacitance		---	110	---	
C <sub>rss</sub>	Reverse Transfer Capacitance		---	98	---	

**Diode Characteristics**

Symbol	Parameter	Conditions	Min.	Typ.	Max.	Unit
I <sub>S</sub>	Continuous Source Current <sup>1,5</sup>	V <sub>G</sub> =V <sub>D</sub> =0V, Force Current	---	---	13	A
V <sub>SD</sub>	Diode Forward Voltage <sup>2</sup>	V <sub>GS</sub> =0V, I <sub>S</sub> =1A, T <sub>J</sub> =25°C	---	---	1.2	V

Note :

- 1.The data tested by surface mounted on a 1 inch<sup>2</sup> FR-4 board with 2OZ copper.
- 2.The data tested by pulsed , pulse width ≤ 300us , duty cycle ≤ 2%
- 3.The power dissipation is limited by 150°C junction temperature
- 4.The data is theoretically the same as I<sub>D</sub> and I<sub>DM</sub> , in real applications , should be limited by total power dissipation.



Typical Characteristics

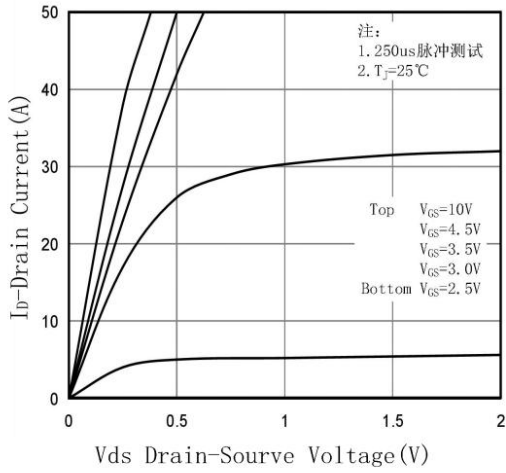

Fig.1 Output Characteristic

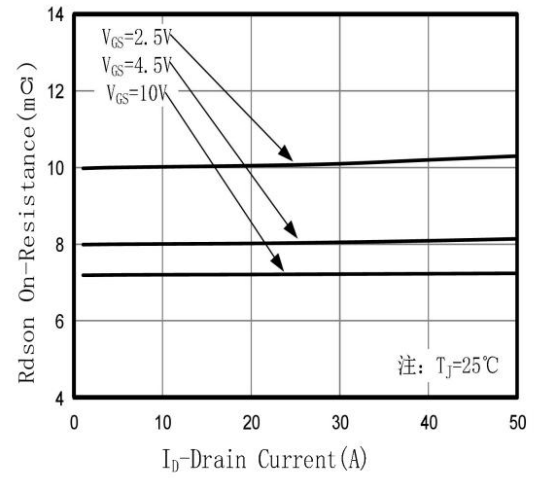

Fig.2 On-Resistance vs. Drain Current

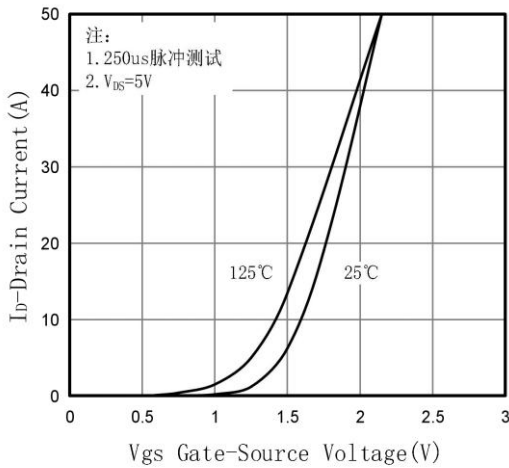

Fig.3 Transfer Characteristic

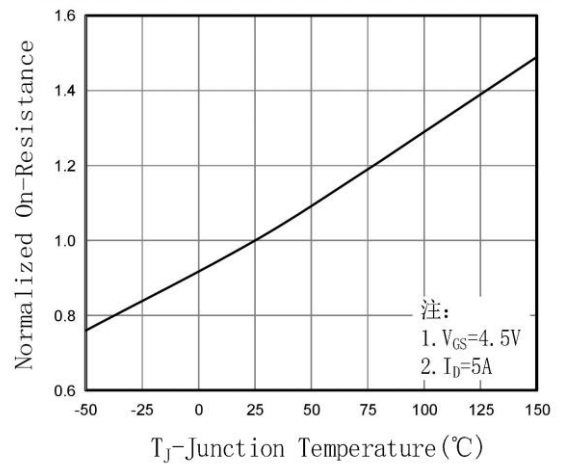

Fig.4 On-Resistance vs. Junction Temperature

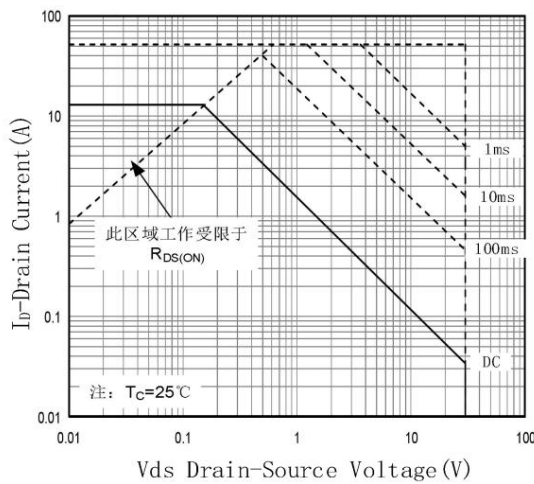

Fig.5 Safe Operation Area

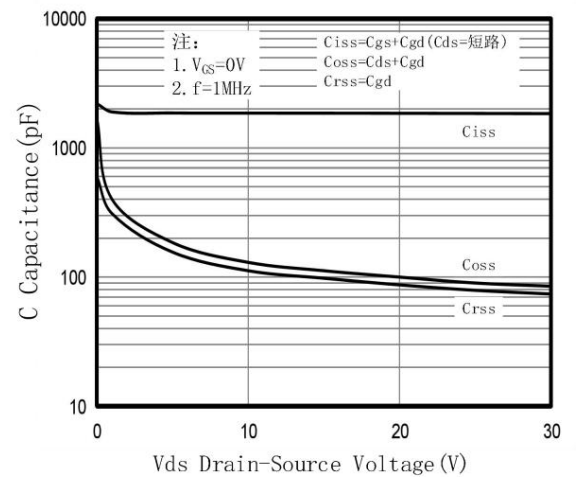
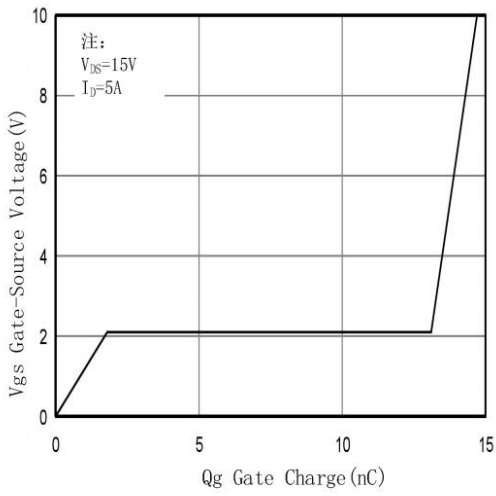
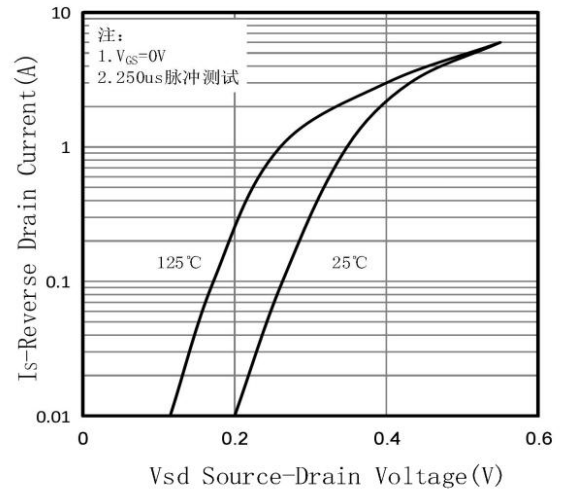

Fig.6 Capacitance Characteristic



**Fig.7 Gate-Charge Characteristic**



**Fig.8 Body Diode Characteristic**

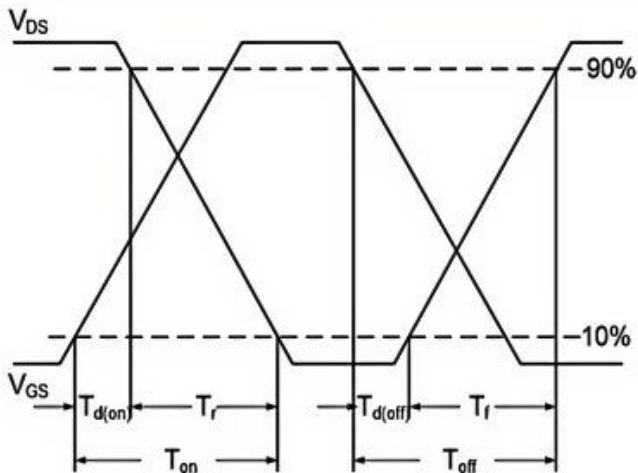

**Fig.9 Switching Time Waveform**

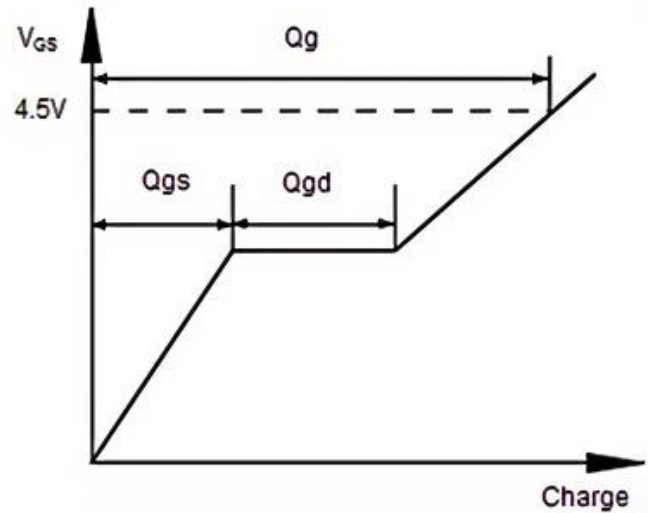
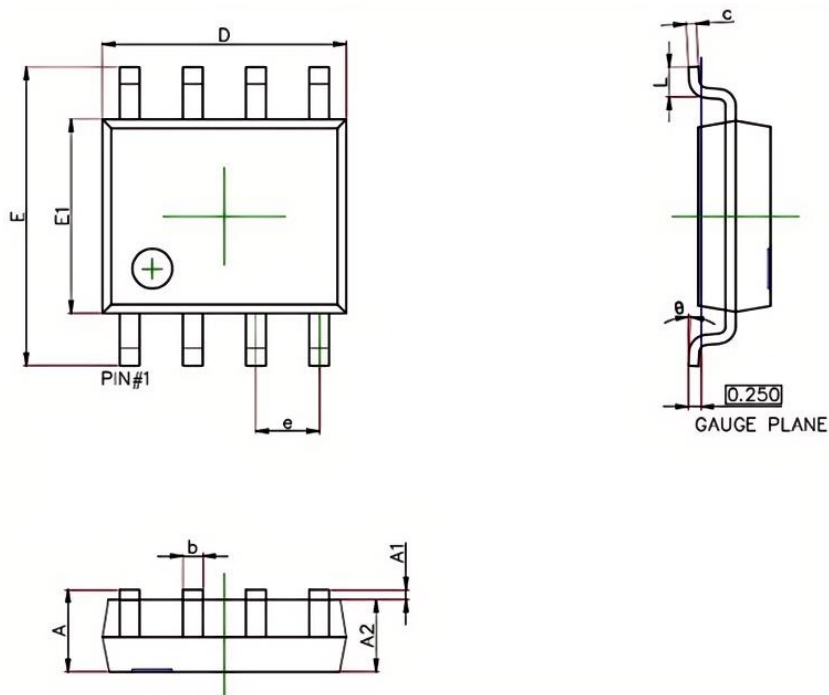

**Fig.10 Gate Charge Waveform**

## Ordering Information

Part Number	Package code	Packaging
HSM4406L	SOP-8	4000/Tape&Reel

## SOP-8 Package Outline



Symbol	Dimensions In Millimeters		Dimensions In Inches	
	Min.	Max.	Min.	Max.
A	1.350	1.750	0.053	0.069
A1	0.100	0.250	0.004	0.010
A2	1.350	1.550	0.053	0.061
b	0.330	0.510	0.013	0.020
C	0.170	0.250	0.007	0.010
D	4.800	5.000	0.189	0.197
e	1.270 (BSC)		0.050(BSC)	
E	5.800	6.200	0.228	0.244
E1	3.800	4.000	0.150	0.157
L	0.400	1.270	0.016	0.050
theta	0°	8°	0°	8°



## HSM4406L Marking:

