

Applications

- Load Switch.
- Power Management.
- LED Backlighting.
- Networking application.

Features

- 100% EAS Guaranteed
- Green Device Available
- Super Low Gate Charge
- Excellent CdV/dt effect decline
- Advanced high cell density Trench Technology

Product Summary

V_{DS}	-150	V
$R_{DS(ON),max}$	780	m Ω
I_D	-3	A

SOT-89 Pin Configuration

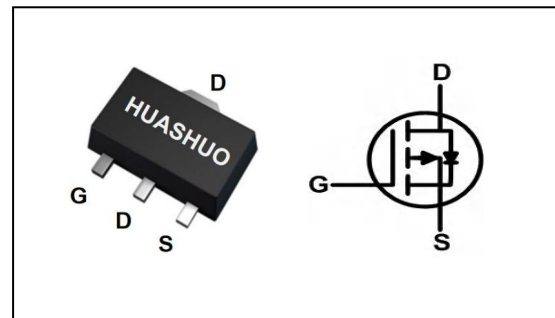

Absolute Maximum Ratings

Symbol	Parameter	Rating	Units
V_{DS}	Drain-Source Voltage	-150	V
V_{GS}	Gate-Source Voltage	± 20	V
$I_D@T_A=25^\circ C$	Continuous Drain Current, $V_{GS} @ 10V^1$	-3	A
$I_D@T_A=70^\circ C$	Continuous Drain Current, $V_{GS} @ 10V^1$	-2.1	A
I_{DM}	Pulsed Drain Current ²	-12	A
EAS	Single Pulse Avalanche Energy ³	12.5	mJ
I_{AS}	Avalanche Current	-5	A
$P_D@T_A=25^\circ C$	Total Power Dissipation ⁴	1.7	W
T_{STG}	Storage Temperature Range	-55 to 150	$^\circ C$
T_J	Operating Junction Temperature Range	-55 to 150	$^\circ C$

Thermal Data

Symbol	Parameter	Typ.	Max.	Unit
$R_{\theta JA}$	Thermal Resistance Junction-Ambient ¹	---	80	$^\circ C/W$
$R_{\theta JC}$	Thermal Resistance Junction-Case ¹	---	40	$^\circ C/W$



Electrical Characteristics (T_J=25 °C, unless otherwise noted)

Symbol	Parameter	Conditions	Min.	Typ.	Max.	Unit
BV _{DSS}	Drain-Source Breakdown Voltage	V _{GS} =0V, I _D =-250uA	-150	---	---	V
R _{DS(ON)}	Static Drain-Source On-Resistance ²	V _{GS} =-10V, I _D =-1A	---	650	780	mΩ
		V _{GS} =-6V, I _D =-0.5A	---	700	980	
V _{GS(th)}	Gate Threshold Voltage	V _{GS} =V _{DS} , I _D =-250uA	-2.0	-3.0	-4.0	V
ΔV _{GS(th)}	V _{GS(th)} Temperature Coefficient		---	5.42	---	mV/°C
I _{DSS}	Drain-Source Leakage Current	V _{DS} =-120V, V _{GS} =0V, T _J =25°C	---	---	1	uA
		V _{DS} =-120V, V _{GS} =0V, T _J =150°C	---	---	30	
I _{GSS}	Gate-Source Leakage Current	V _{GS} =±20V, V _{DS} =0V	---	---	±100	nA
R _g	Gate Resistance	V _{DS} =0V, V _{GS} =0V, f=1MHz	---	12	---	Ω
Q _g	Total Gate Charge (-4.5V)	V _{DS} =-75V, V _{GS} =-10V, I _D =-1A	---	10.5	---	nC
Q _{gs}	Gate-Source Charge		---	3.2	---	
Q _{gd}	Gate-Drain Charge		---	2.3	---	
T _{d(on)}	Turn-On Delay Time	V _{DD} =-30V, V _{GS} =-10V, R _G =6Ω, I _D =-1A	---	21	---	ns
T _r	Rise Time		---	17	---	
T _{d(off)}	Turn-Off Delay Time		---	40	---	
T _f	Fall Time		---	18	---	
C _{iss}	Input Capacitance	V _{DS} =-75V, V _{GS} =0V, F=1MHz	---	715	---	pF
C _{oss}	Output Capacitance		---	21	---	
C _{rss}	Reverse Transfer Capacitance		---	14	---	

Diode Characteristics

Symbol	Parameter	Conditions	Min.	Typ.	Max.	Unit
I _S	Continuous Source Current ^{1,6}	V _G =V _D =0V, Force Current	---	---	-3	A
V _{SD}	Diode Forward Voltage ²	V _{GS} =0V, I _S =-1A, T _J =25°C	---	---	-1.2	V

Note :

- 1.The data tested by surface mounted on a 1 inch² FR-4 board with 2OZ copper.
- 2.The data tested by pulsed , pulse width ≤ 300us , duty cycle ≤ 2%
- 3.The power dissipation is limited by 150°C junction temperature
- 4.The data is theoretically the same as I_D and I_{DM} , in real applications , should be limited by total power dissipation.

P-Ch 150V Fast Switching MOSFETs

P-Channel Typical Characteristics

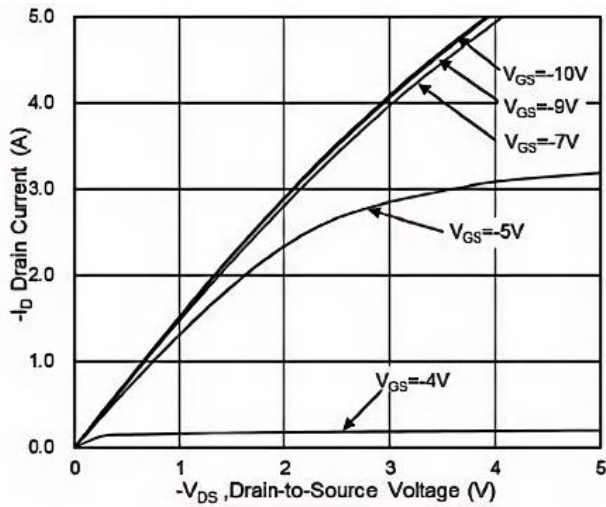

Fig.1 Typical Output Characteristics

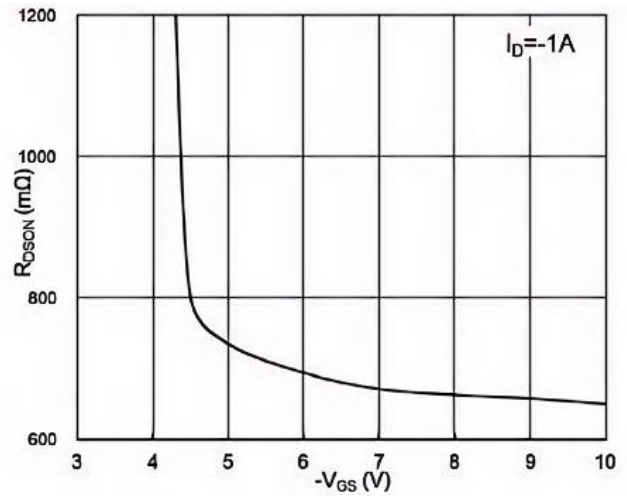

Fig.2 On-Resistance vs. G-S Voltage

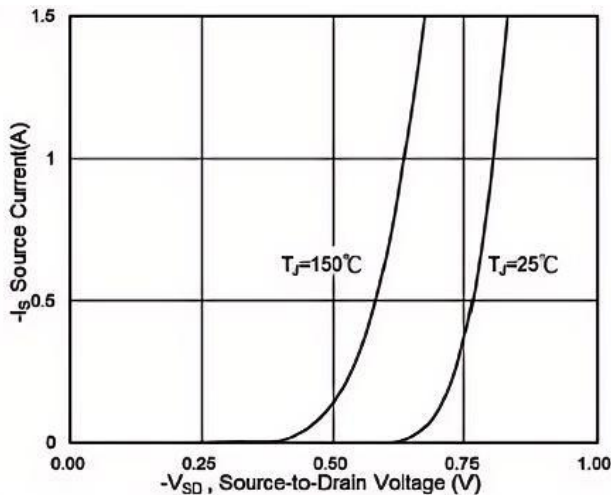

Fig.3 Forward Characteristics Of Reverse

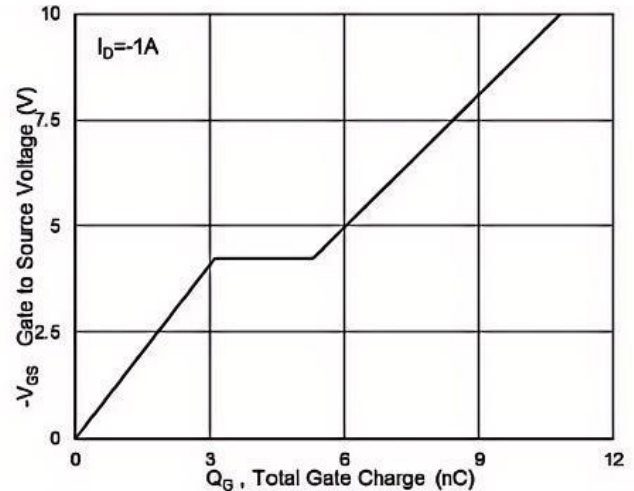

Fig.4 Gate-Charge Characteristics

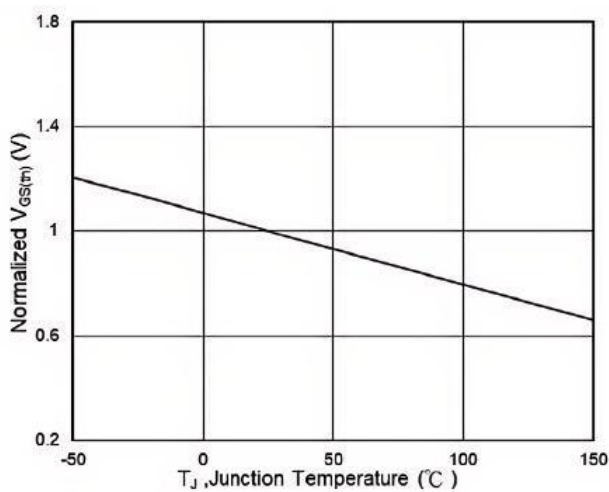

Fig.5 Normalized $V_{GS(th)}$ vs. T_J

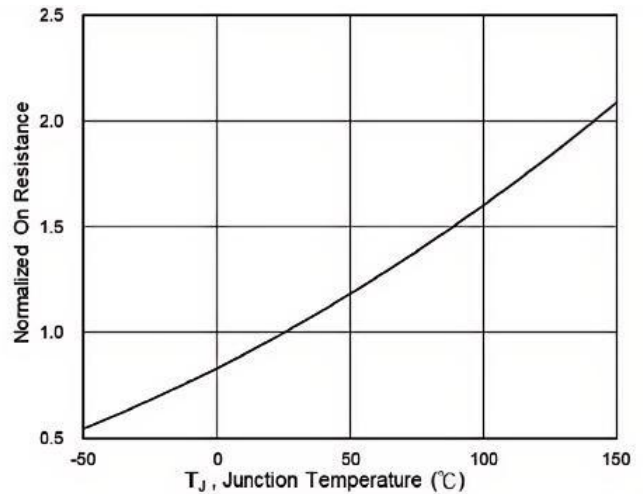

Fig.6 Normalized $R_{DS(on)}$ vs. T_J

P-Ch 150V Fast Switching MOSFETs

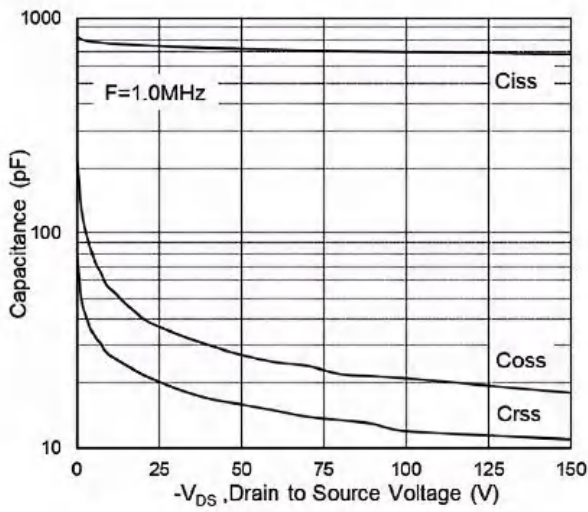

Fig.7 Capacitance

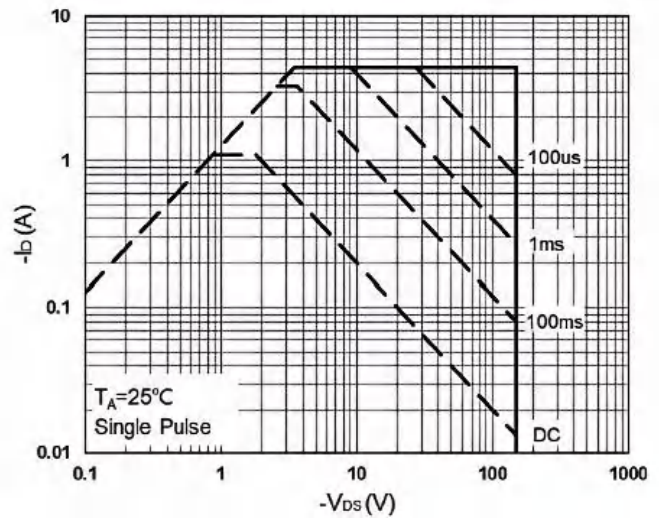

Fig.8 Safe Operating Area

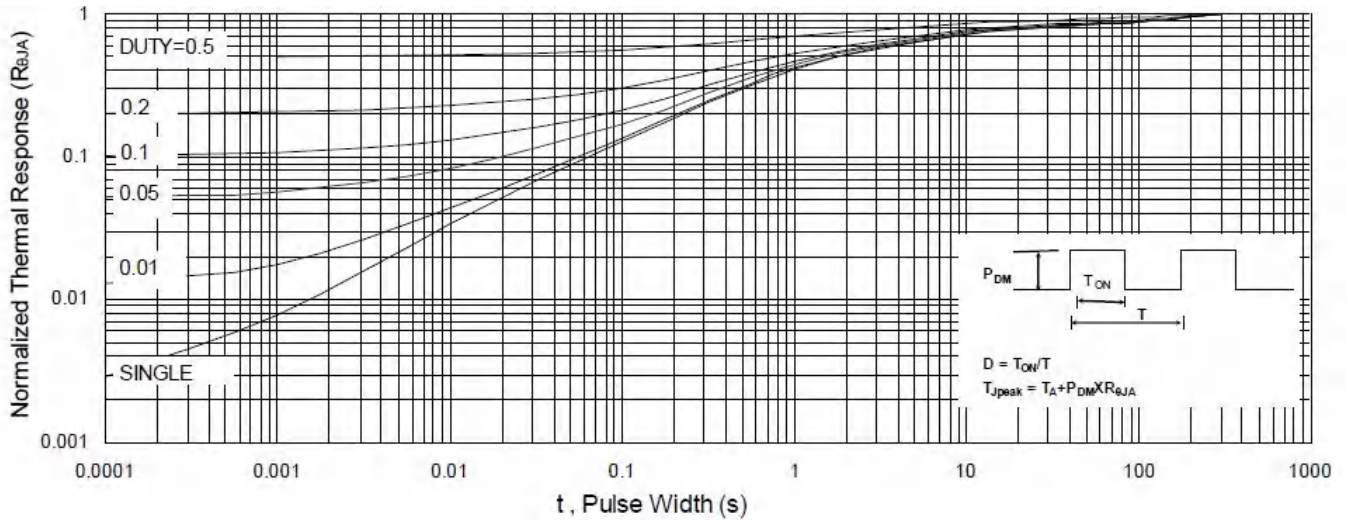

Fig.9 Normalized Maximum Transient Thermal Impedance

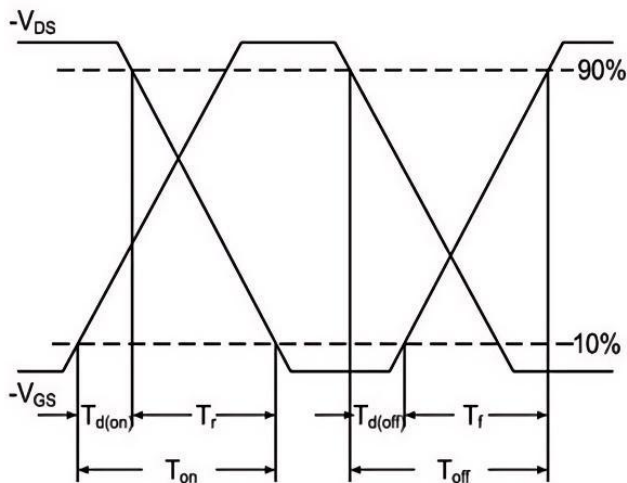

Fig.10 Switching Time Waveform

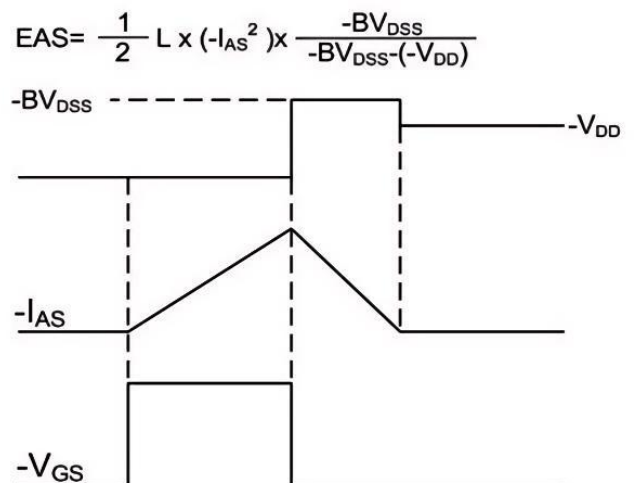

Fig.11 Unclamped Inductive Waveform



Ordering Information

Part Number	Package code	Packaging
HSK3P15	SOT-89	1000/Tape&Reel

SOT-89 Package Outline

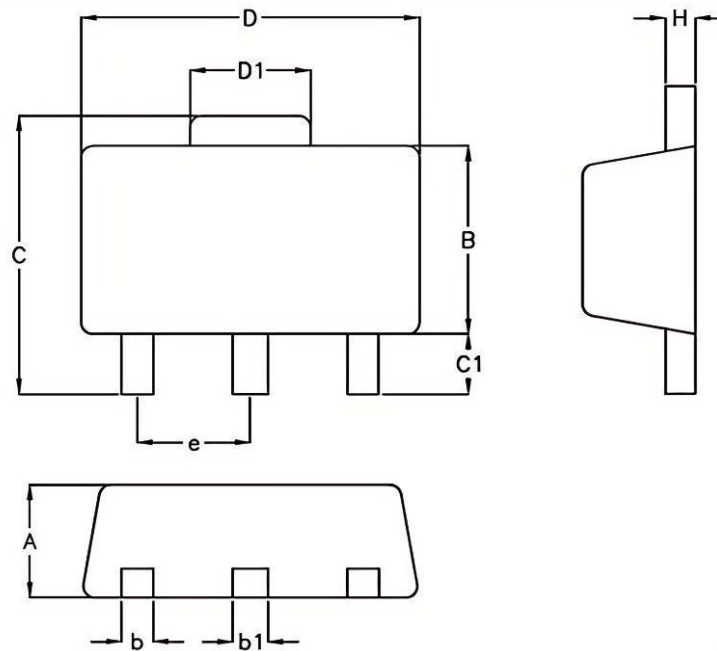

SYMBOLS	MILLIMETERS		NCHEES	
	MIN	MAX	MIN	MAX
A	1.397	1.600	0.055	0.063
b	0.420	0.540	0.017	0.021
b1	0.420	0.540	0.017	0.021
B	2.388	2.591	0.094	0.102
C	3.937	4.242	0.155	0.167
C1	0.787	1.194	0.031	0.047
D	4.394	4.597	0.173	0.181
D1	1.397	1.753	0.055	0.069
e	1.448	1.549	0.057	0.061
H	0.350	0.44	0.014	0.017

HSK3P15 Marking:

