

Features

- Complete Unipolar High-Side Current Measurement Circuit
- Wide Supply and Common-Mode Range
- Inputs accept voltages up to 36 V
- Independent Supply and Input Common-Mode Voltages
- Single Resistor Gain Set
- Low Quiescent Current
- package: SOT23

Applications

- Current Shunt Measurement:
 - Automotive, Telephone, Computers
- Portable and Battery-Backup Systems
- Precision Current Source
- Power Management
- Battery Chargers

General Description

The is are high side unipolar current sense monitors. These devices eliminate the need to disrupt the ground plane when sensing a load current.

The wide common-mode input voltage range and low quiescent current coupled with SOT23 packages make them suitable for a range of applications; including adapters, automotive and systems operating from industrial 24V rails.

The device is line powered and as such doesn't need a separate supply rail. thereby minimising current sensing error. One external gain setting resistor increases versatility by permitting wide gain ranges.

Pinout (top view)

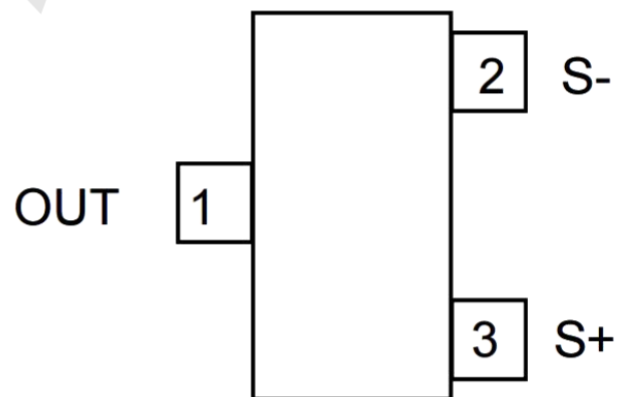

Pin Configurations

Pin Number	Pin Name	Pin Function
1	OUT	Output pin. Current output.
2	S-	This is the negative input of the current monitor and has a wide common-mode input range.
3	S+	This is the positive input of the current monitor and has a wide common-mode input range. This also acts as the analog supply and provides power to internal circuitry. The current through this pin varies with differential sense voltage.

BLOCK DIAGRAM

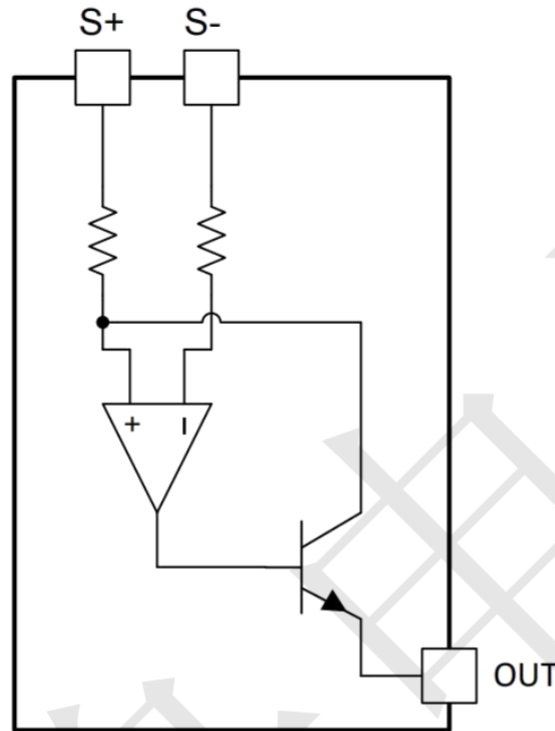

Typical working circuit

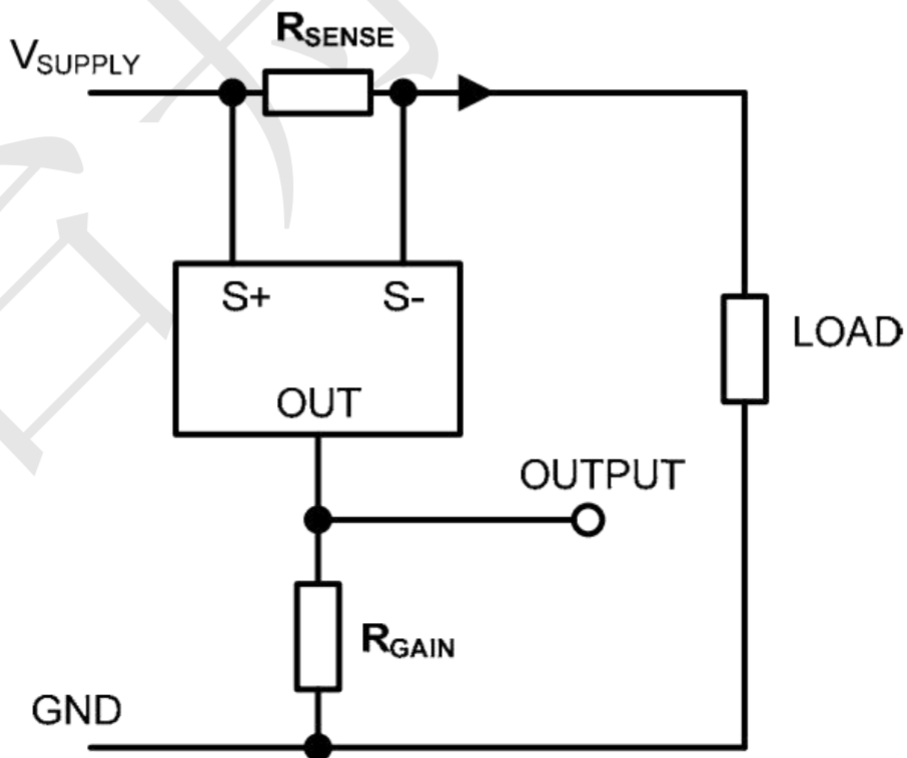

Absolute Maximum Ratings

		MIN	MAX	UNIT
Voltage on S- and S+ relative to OUT		-0.3	40	V
Differential Sense Voltage, V_{SENSE} ^(1,2)		-0.3	0.8	V
Current into S+ and S- ⁽²⁾		10		mA
Operating temperature		-55	125	°C
T_J	Junction temperature	150		°C
T_{stg}	Storage temperature	-65	125	°C

Operation above the absolute maximum rating may cause device failure. Operation at the absolute maximum ratings, for extended periods, may reduce device reliability.

Notes: 1. $V_{SENSE} = V_{S+} - V_{S-}$

2. The differential input voltage limit, $V_{S+} - V_{S-}$, may be exceeded provided that the input current limit into S+ or S- is not exceeded.

ESD Level

		VALUE	UNIT
$V_{(ESD)}$ Electrostatic discharge	Human body model (HBM), per ANSI/ESDA/JEDEC JS-001, all pins ⁽³⁾	±1000	V
	Charged device model (CDM), per JEDEC specification JESD22-C101, all pins ⁽⁴⁾	±500	

Notes: 3, JEDEC document JEP155 states that 500-V HBM allows safe manufacturing with a standard ESD control process.

4, JEDEC document JEP157 states that 250-V CDM allows safe manufacturing with a standard ESD control process.

Recommended Operating Conditions

over operating free-air temperature range (unless otherwise noted)

		MIN	MAX	UNIT
V_{S+}	Common-mode input range ⁽⁵⁾	2.5	36	V
V_{SENSE}	Differential Sense Input voltage range ($V_{S+} - V_{S-}$)	0	0.5	V
V_{OUT}	Output voltage range ($0 \leq V_{SENSE} \leq 100mV$)	0	$V_{S+} - 2.5$	V
Operating temperature		-40	85	°C
Thermal Resistance, θ_{JA}		200		°C/W

Notes. 5. For the pin 1 (OUT) acts as both the output pin and substrate connection. This means that for the the minimum rail voltage that can be used is $2.5V + V_{OUT}$

Electrical Characteristics ($T_A = 25^\circ\text{C}$, $V_{S+} = 20\text{V}$, $V^{(6)} = 100\text{mV}$, $R_{\text{GAIN}} = 0$ unless otherwise stated)

Symbol	Parameter	Conditions	T_A	Min	Typ	Max	Units	
I_{S-}	S- input current	$V_{\text{SENSE}}^{(6)} = 0\text{V}$	25°C	--	19	100	nA	
			-40°C	--	16	--		
			85°C	--	35	--		
I_{OUT}	Output current ⁶	$V_{\text{SENSE}}^{(6)} = 0\text{mV}$	25°C	1	3	10	μA	
			-40°C	--	2.2	--		
			85°C	--	5.5	--		
		$V_{\text{SENSE}}^{(6)} = 10\text{mV}$	25°C	37	45	54		
			-40°C	--	42	--		
			85°C	--	49	--		
		$V_{\text{SENSE}}^{(6)} = 30\text{mV}$	25°C	115	124	134		
			-40°C	--	119	--		
			85°C	--	129	--		
		$V_{\text{SENSE}}^{(6)} = 100\text{mV}$	25°C	394	408	422		
			-40°C	--	396	--		
			85°C	--	420	--		
		$V_{\text{SENSE}}^{(6)} = 200\text{mV}$	25°C	787	810	832		
			-40°C	--	785	--		
			85°C	--	832	--		
		$V_{\text{SENSE}}^{(6)} = 500\text{mV}$	25°C	1.965	2.015	2.064		mA
			-40°C	--	1.965	--		
			85°C	--	2.065	--		
$I_{\text{OUT-TC}}$	Output current temperature coefficient		full range	--	370	--	ppm/ $^\circ\text{C}$	
CMSR	Common-Mode Sense rejection	$V_{S+} = 2.5\text{V}$ to 36V	25°C	--	0.1	0.4	$\mu\text{A/V}$	
			-40°C	--	0.13	--		
			85°C	--	0.05	--		
BW	-3dB Small Signal Bandwidth	$V_{\text{SENSE}}^{(6)}(\text{AC}) = 10\text{mV}_{\text{PP}}$ $R_{\text{GAIN}} = 2.5\text{k}\Omega$	25°C	--	0.65	--	MHz	

Notes. 6. $V_{\text{SENSE}} = "V_{\text{SENSE}+}" - "V_{\text{SENSE}-}"$

Typical Characteristics

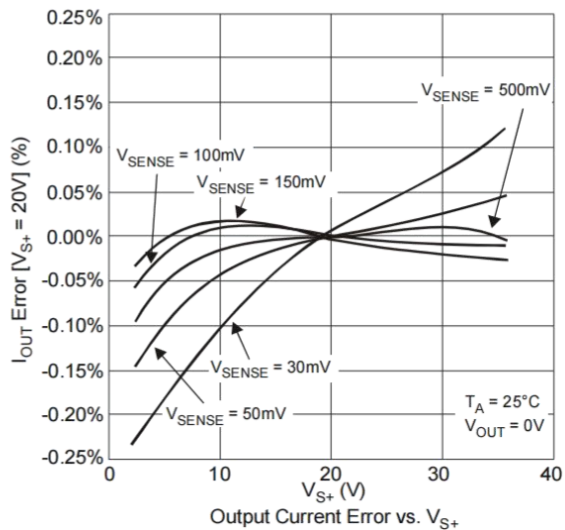
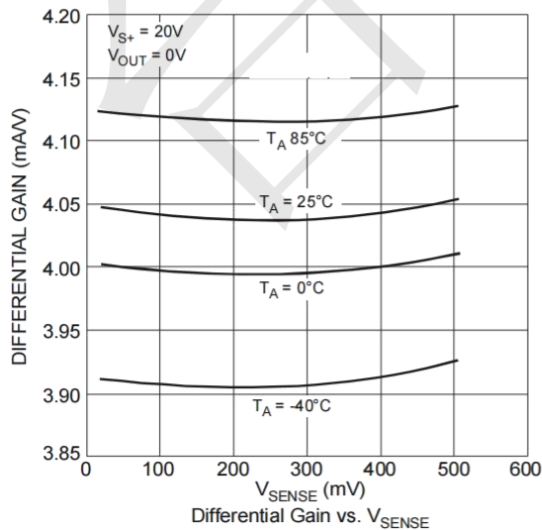
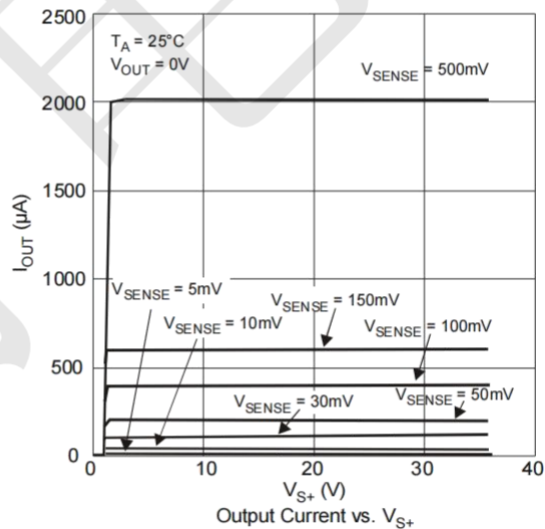
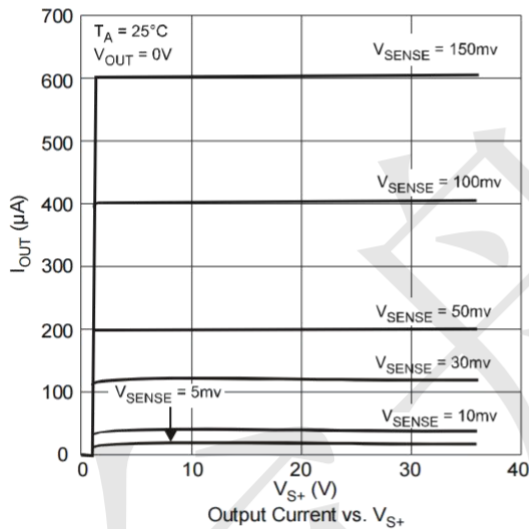
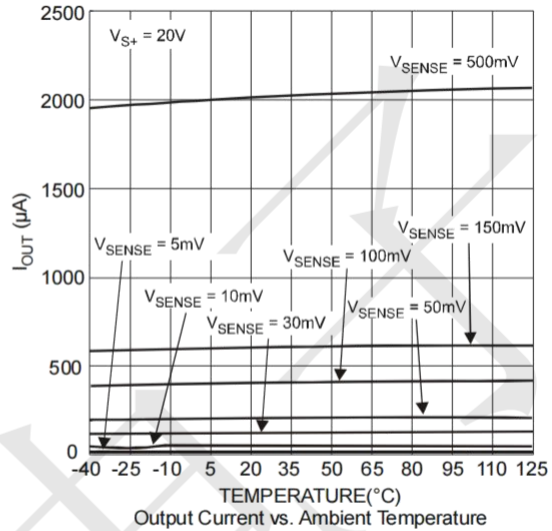
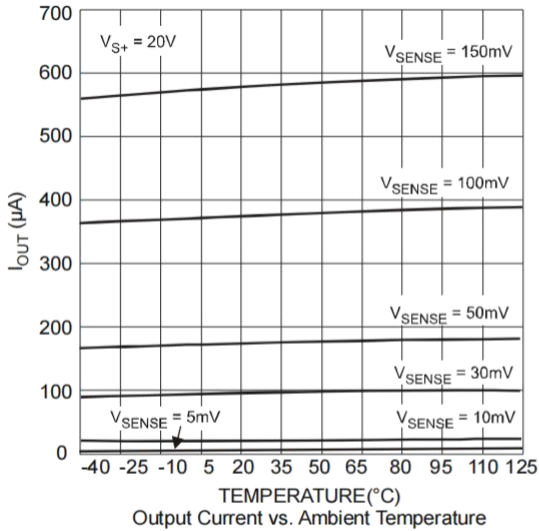

Package Outline Dimensions (unit: mm)

SOT-23

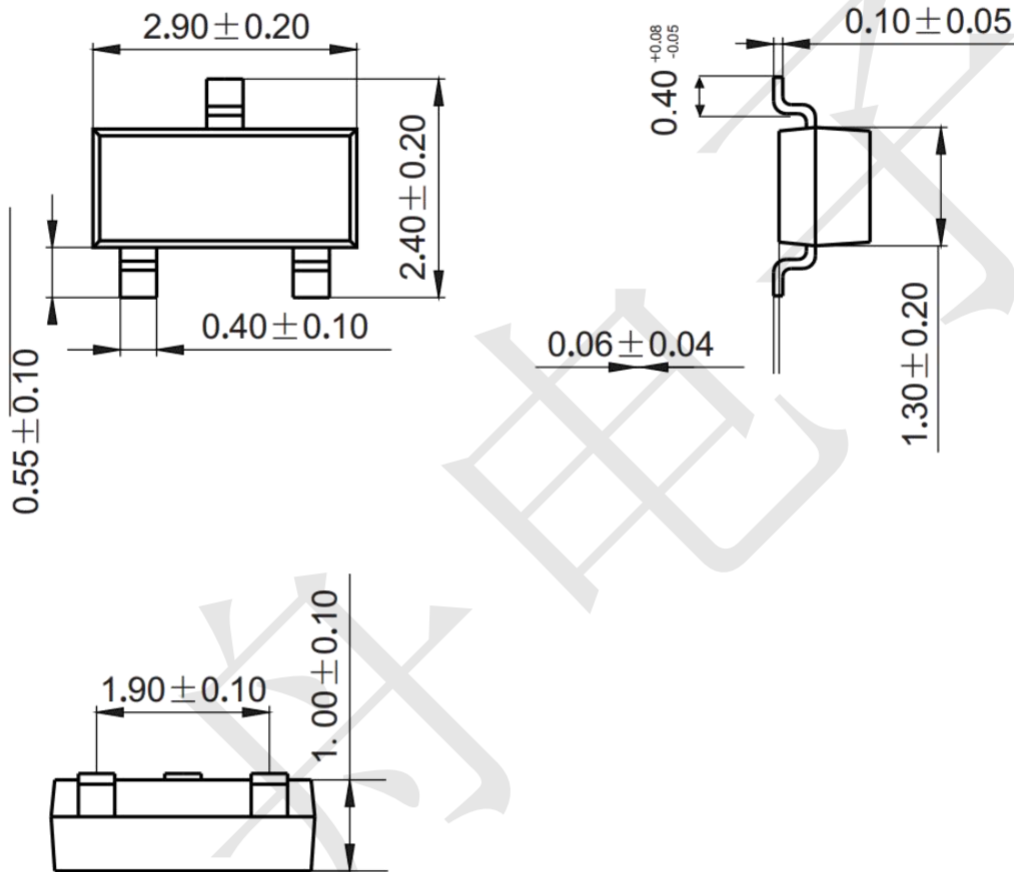

Mounting Pad Layout (unit: mm)

