

### Product Summary

- $BVC_{BO} \geq 50V(I_C=100\mu A)$
- $BVCE_{O} \geq 45V(I_C=10mA)$
- $I_C = 100mA$

### Features

- Consumer electronics
- Voltage switching
- High Speed Switching

### Circuit diagram and pin information

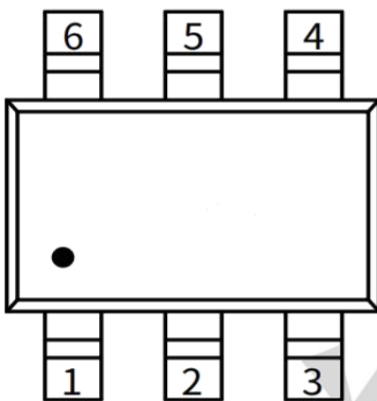

SOT-363

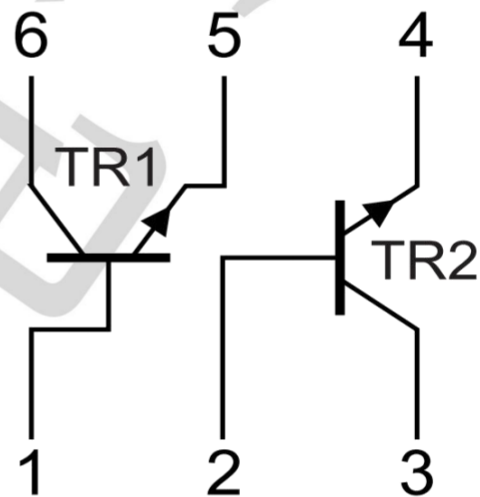

### Absolute Maximum Ratings

( $T_A=25^{\circ}C$  unless otherwise specified)

PARAMETER	SYMBOL	LIMIT	UNIT
Collector-Base Voltage	$V_{CBO}$	50	V
Collector-Emitter Voltage	$V_{CEO}$	45	V
Emitter-Base Voltage	$V_{EBO}$	6	V
Collector Current (DC)	$I_C$	100	mA
Collector Peak Current (Pulse) Single pulse, $P_w \leq 380\mu s$ , Duty $\leq 2\%$	$I_{CM}$	200	mA
Power Total Dissipation @ $T_A=25^{\circ}C$	$P_D$	0.2	W
Maximum Operating Junction Temperature	$T_J$	+150	$^{\circ}C$
Storage Temperature Range	$T_{STG}$	-55 to +150	$^{\circ}C$

Note:1.Device mounted on a printed-circuit board, single sided copper, tinplated, mounting pad for collector 1 cm<sup>2</sup>.

## Electrical Characteristics

(TA=25°C unless otherwise specified)

PARAMETER	CONDITIONS	SYMBOL	MIN	TYP	MAX	UNIT
<b>Static (Note 1)</b>						
Collector-Base Breakdown Voltage	$I_C = 100\mu A, I_E = 0$	$BV_{CBO}$	50	--	--	V
Collector-Emitter Breakdown Voltage	$I_C = 10mA, I_B = 0$	$BV_{CEO}$	45	--	--	V
Emitter-Base Breakdown Voltage	$I_E = 100\mu A, I_C = 0$	$BV_{EBO}$	6	--	--	V
Collector Cutoff Current	$V_{CB} = 50V, I_E = 0$	$I_{CBO}$	--	--	0.1	$\mu A$
Emitter Cutoff Current	$V_{EB} = 5V, I_C = 0$	$I_{EBO}$	--	--	0.1	$\mu A$
Collector-Emitter Saturation Voltage	$I_C = 10mA, I_B = 0.5mA$	$V_{CE(SAT)1}$	--	--	0.2	V
	$I_C = 100mA, I_B = 5mA$	$V_{CE(SAT)2}$	--	--	0.4	V
DC Current Transfer Ratio	$V_{CE} = 5V, I_C = 10\mu A$	$h_{FE1}$	--	250	--	
	$V_{CE} = 5V, I_C = 2mA$	$h_{FE2}$	200	300	450	
<b>Dynamic (Note 2)</b>						
Transition Frequency	$V_{CE} = 5V, I_C = 10mA, f = 100MHz$	$f_T$	100	250	--	MHz
Collector Output Capacitance	$V_{CB} = 10V, I_E = 0A, f = 1MHz$	$C_C$	--	--	1.5	pF
Emitter Capacitance	$V_{EB} = 0.5V, I_E = 0A, f = 1MHz$	$C_e$	--	11	--	pF
noise figure	$V_{CE} = 5V;$ $I_C = 0.2mA;$ $R_S = 2k\Omega;$ $f = 10Hz$ to $15.7kHz$	NF	--	2.8	--	dB

Note:

- 1.Pulse test:  $\leq 380\mu s$ , duty cycle  $\leq 2\%$
- 2.For DESIGN AID ONLY, not subject to production testing

**Typical Performance Characteristics(TA=25°C )**

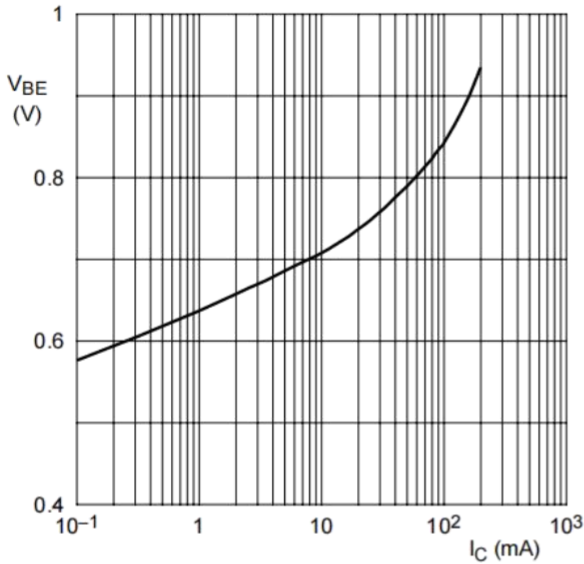

$V_{CE} = 5 \text{ V}; T_{amb} = 25 \text{ }^\circ\text{C}$

**Base-emitter voltage as a function of collector current; typical values**

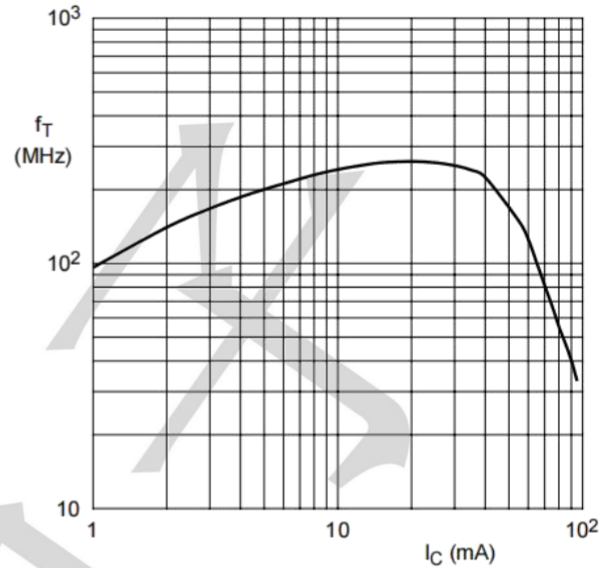

$V_{CE} = 5 \text{ V}; T_{amb} = 25 \text{ }^\circ\text{C}$

**Transition frequency as a function of collector current; typical values**

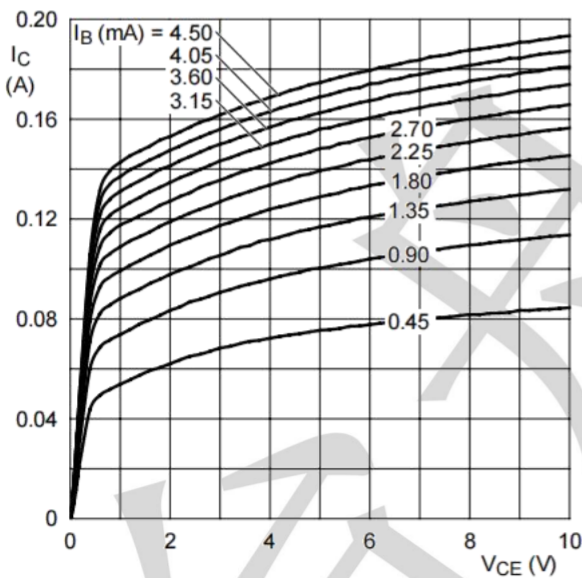

$T_{amb} = 25 \text{ }^\circ\text{C}$

**Collector current as a function of collector-emitter voltage; typical values**

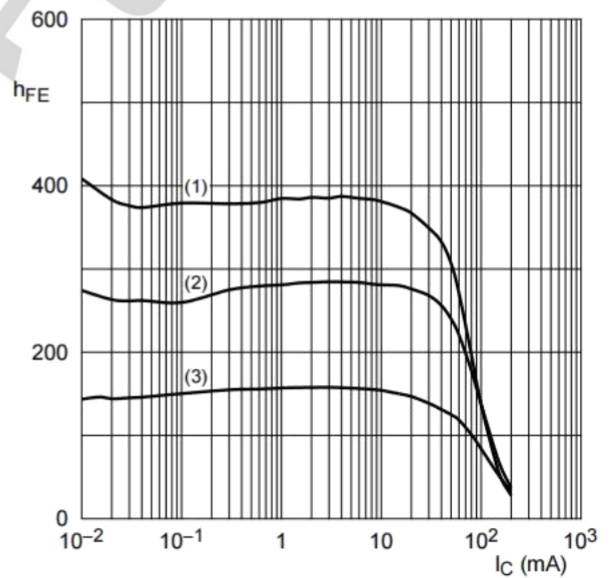

$V_{CE} = 5 \text{ V}$  (1)  $T_{amb} = 100 \text{ }^\circ\text{C}$  (2)  $T_{amb} = 25 \text{ }^\circ\text{C}$   
(3)  $T_{amb} = -55 \text{ }^\circ\text{C}$

**DC current gain as a function of collector current; typical values**

**Package information (Unit: mm)**

SOT-363

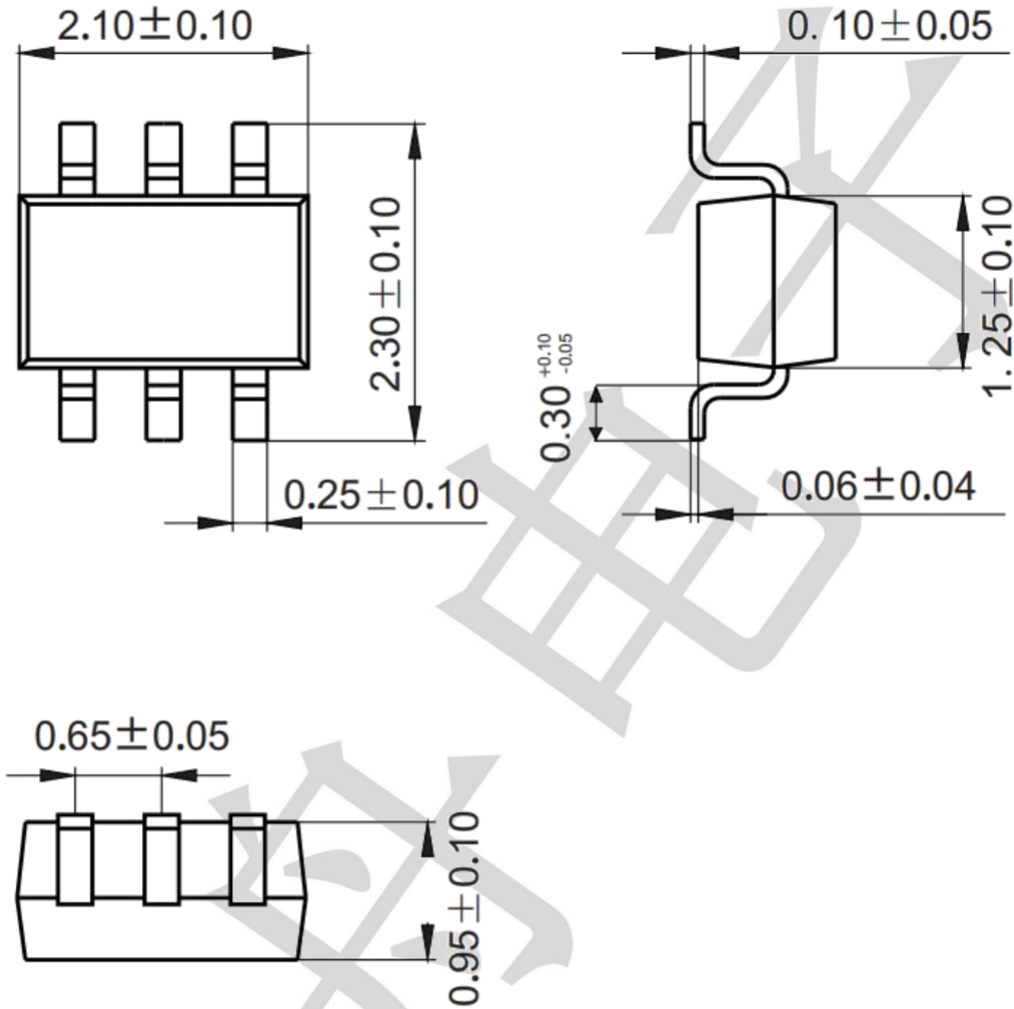

**Mounting Pad Layout (unit: mm)**

