

## Specification for Approval

Customer : \_\_\_\_\_

Product Type : SMD CXO 3 . 2 × 2.5

Nominal Freq. : 38.4MHz

STARWAVE P/N : SWOCCV12S8-38.400000

Revision : A1

Customer P/N : \_\_\_\_\_

PM / Sales : \_\_\_\_\_

Date : \_\_\_\_\_

Customer Confirmation : \_\_\_\_\_  
(Singnature)

(Date)

- (1) STARWAVE requires one copy returned with signature and title of authorized individual that signifies acceptance of the attached specifications.
- (2) Orders received and accepted by STARWAVE after return of signed copy of specification will be produced per these specifications.
- (3) Any changes to these specifications must be agreed upon by both parties and new revision of the Product Specification Sheet will be issued.
- (4) Any issuance of purchase order prior to consigning back the Approval page of "Specification Sheets" from customers will be regarded as the agreement on the contents of these specifications.

**MSL:Level 1**  
**RoHS Compliant**

## Product Specification Sheet

Product Type : SMD CXO 3 . 2 × 2 . 5

Nominal Freq. : 38.4MHz

STARWAVE P/N : SWOCCV12S8-38.400000

Revision : A1

PE/RD	QA	MFG
Zhang fen qi	Xu wen tao	Luo jun jie
05-Feb-26	05-Feb-26	05-Feb-26

Note:

- (1) The green product standard set by STARWAVE is based upon the international standards. Related information is publicly described on the STARWAVE's Website, and updated regularly. The document is compliant with the latest green product quality system directives at the time.
- (2) Revision "Sx" is for engineering samples only. PE/RD's approval required.
- (3) Revision "Ax" is production ready. PE, QA and MFG's approval required.

**MSL:Level 1**  
**RoHS Compliant**



## ■ Electrical Specifications

### Standard Atmospheric Conditions

Unless otherwise specified, the standard range of atmospheric conditions for making measurement and tests are as follow:

Ambient temperature : 25±5°C  
 Relative humidity : 40%~70%

If there is any doubt about the results, measurement shall be made within the following limits:

Ambient temperature : 25±3°C  
 Relative humidity : 40%~70%

### Measure Equipment

Electrical characteristics measured by MD600F or equivalent.

### Crystal Cutting Type

The crystal is using AT CUT (thickness shear mode).

### Unit Weight:

0.015±0.002 g/pcs

	Parameters	Symbol	Electrical Spec.				Notes
			Min.	Typ.	Max.	Units	
1	Nominal Frequency	-	38.400000			MHz	-
2	Frequency Stability	-	±30			ppm	±10PPM@25°C -
3	Operating Temperature	Topr	-40	25	85	°C	-
4	Storage Temperature	Tstg	-55	~	125	°C	-
5	Supply Voltage	VDD	1.2V±10%			V	-
6	Input Current	Icc	-	-	10	mA	-
7	Enable Control	-	Yes			-	Pad 1
8	Output Load : CMOS	CL	15			pF	-
9	Output Voltage High	VoH	90%Vdd	-	-	V	-
10	Output Voltage Low	VoL	-	-	10%Vdd	V	-
11	Rise Time	Tr	-	-	5	ns	10%→90%VDD Level
12	Fall Time	Tf	-	-	5	ns	90%→10%VDD Level
13	Symmetry (Duty ratio)	TH/T	45	~	55	%	-
14	Start-up Time	Tosc	-	-	10	ms	-
15	Enable Voltage High	Vhi	70%Vdd	-	-	V	-
16	Disable Voltage Low	Vlo	-	-	30%Vdd	V	-
17	Aging	-	±3			ppm/yr.	1st. Year at 25°C

## ■ DIMENSIONS

(Unit:mm)

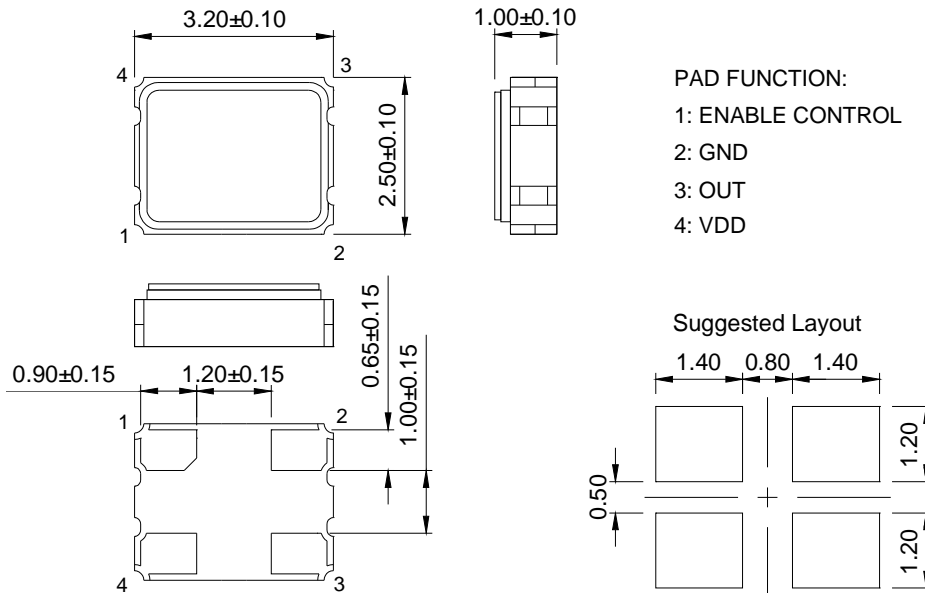

PAD FUNCTION:

- 1: ENABLE CONTROL
- 2: GND
- 3: OUT
- 4: VDD

## ■ MARKING

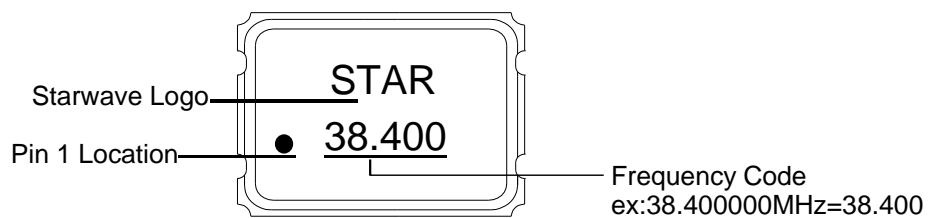

Production Location:NINGBO

According to the Customer Marking Rule, the product has no traceability.

## ■ TEST DIAGRAM

- Control input (output enable/disable)
- Logic 1 or open on pad 1: Oscillator output
- Logic 0 on pad 1 : Disable output to high impedance

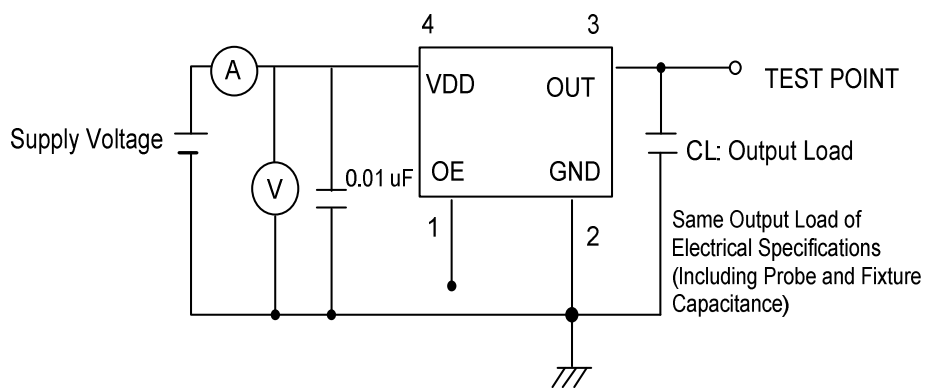

## ■ WAVEFORM CONDITIONS

Waveform measurement system should have a min. bandwidth of 5 times the frequency being tested.

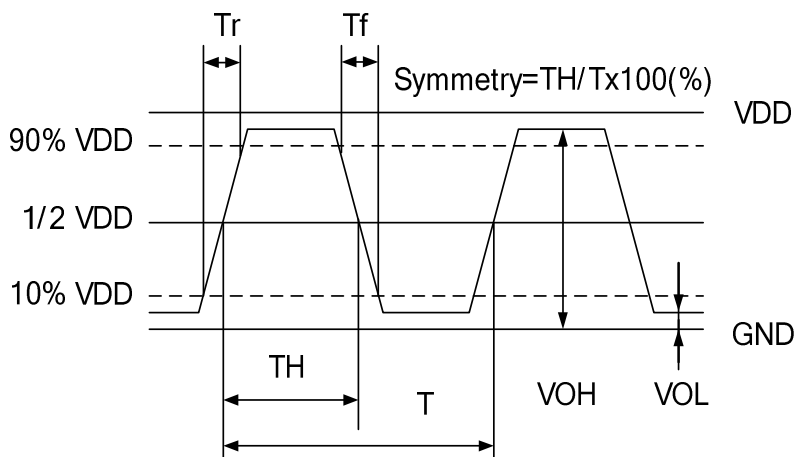

## ■ OUTPUT ENABLE / DISABLE DELAY

The following figure shows the oscillator timing during normal operation . Note that when the device is in standby, the oscillator stops. When standby is released, the oscillator starts and stable oscillator output occurs after a short delay.

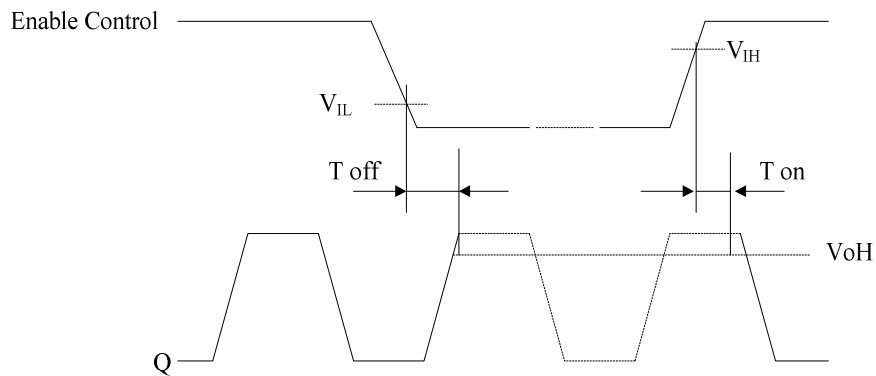

## ■ SUGGESTED REFLOW PROFILE

Total time : 200 sec. Max.

Solder melting point :220 °C

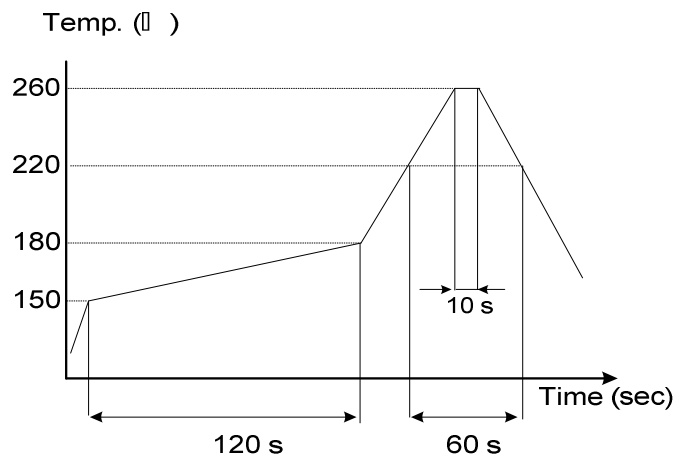

## ■ STRUCTURE ILLUSTRATION

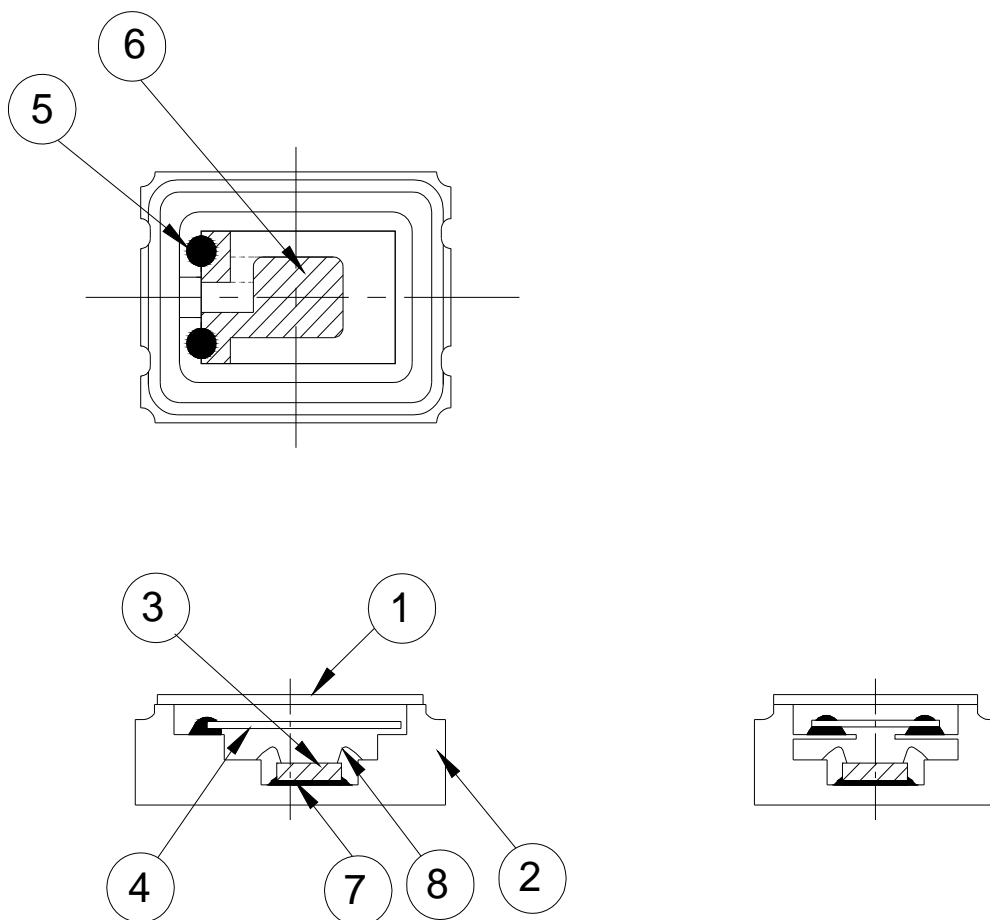

NO	COMPONENTS	MATERIALS	FINISH/SPECIFICATIONS
1	Lid	Kovar (Fe/Co/Ni)	-
2	Base (Package)	Ceramic (Al <sub>2</sub> O <sub>3</sub> ) + Kovar (Fe/Co/Ni)+ Ag/Cu	-
3	IC chip	-	-
4	Crystal blank	SiO <sub>2</sub>	-
5	Conductive adhesive	Ag	Silicon resin
6	Electrode	Noble Metal	-
7	Die attached	Conductive (Ag)	Epoxy resin
8	Bonding wire	Au	Pad 1 options : NC is 5 wires , EN is 6 wires.

## PACKING

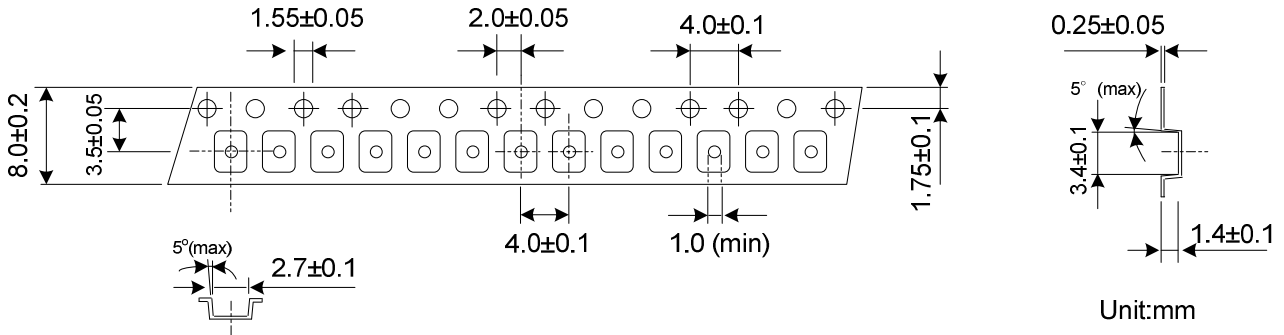

## REMARK :

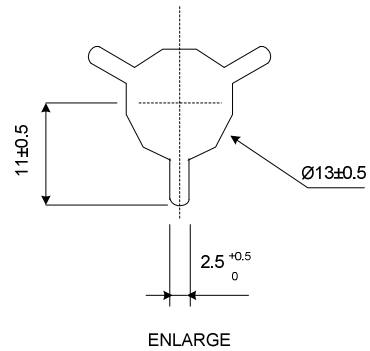
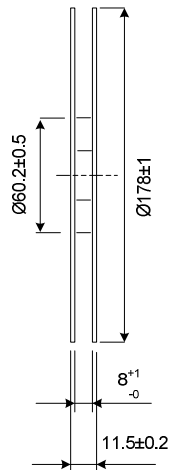
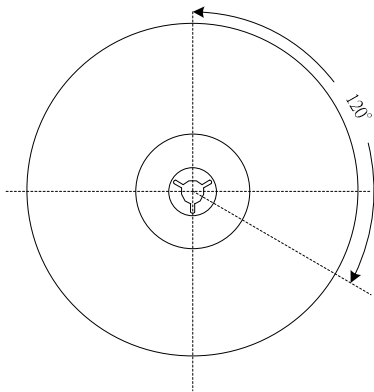
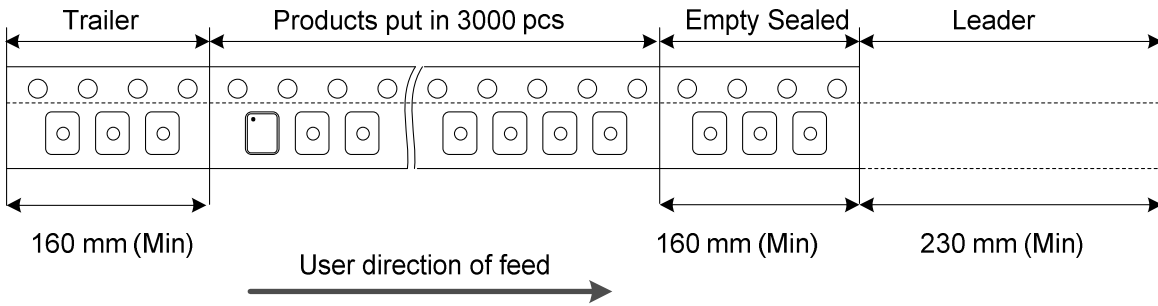

## ■ Reliability Specifications

### 1. Mechanical Endurance

No.	Test Item	Test Methods	REF. DOC
1	Drop Test	75 cm height, 3 times on concrete floor .	JIS C6701
1	Mechanical Shock	Device are shocked to half sine wave ( 1000 G ) three mutually perpendicular axes each 3 times. 0.5m sec. duration time	MIL-STD-202
1	Vibration	Frequency range                      10 ~ 2000 Hz Amplitude                                 1.52 mm/20G Sweep time                                20 minutes perpendicular axes each test time 4 Hrs (Total test time 12 Hrs)	MIL-STD-883
1	Gross Leak	Standard Sample For Automatic Gross Leak Detector, Test Pressure: 2kg / cm <sup>2</sup>	MIL-STD-883
2	Fine Leak	Helium Bombing 4.5 kgf / cm <sup>2</sup> for 2 Hrs	MIL-STD-883
2	Solderability	Temperature                              245 °C ± 5°C Immersing depth                         0.5 mm minimum Immersion time                          5 ± 1 seconds Flux    Rosin resin methyl alcohol solvent ( 1 : 4 )	MIL-STD-883

### 2. Environmental Endurance

No.	Test Item	Test Methods	REF. DOC
2	Resistance To Soldering Heat	Pre-heat temperature                 125 °C Pre-heat time                             60 ~ 120 sec. Test temperature                         260 ± 5 °C Test time                                    10 ± 1 sec.	MIL-STD-202
2	High Temp. Storage	+ 125 °C ± 3 °C for 1000 ± 12 Hrs	MIL-STD-883
2	Low Temp. Storage	- 40 °C ± 3 °C for 1000 ± 12 Hrs	
2	Thermal Shock	Total 100 cycles of the following temperature cycle 	MIL-STD-883
3	High Temp & Humidity	85°C ± 3°C, RH 85% , 1000 Hrs	EIA-JESD22
3	Pressure Cooker Storage	121 ± 3°C , RH100% , 2 bar , 240 Hrs	EIA-JESD22